

These drawings are published as an information guide only. These CAD drawings are intended as templates to assist the designer, they do not contain the full detail required for construction and must be read in conjunction with the installation instructions on www.longboardproducts.com. You should obtain architectural, engineering or other technical advice to assess the suitability of these drawings to the requirements of your particular project. Mayne Coatings Corp. and Longboard products accepts no liability in respect to the use of these drawings.

For complete installation instructions refer to the appropriate documentation at www.longboardsuppliers.com/installation

4" DAUNTLESS BEAM
 ALUMINUM ALLOY: 6063-T5
 WEIGHT: 1.19 LBS/ LF
 SCALE: 1:1

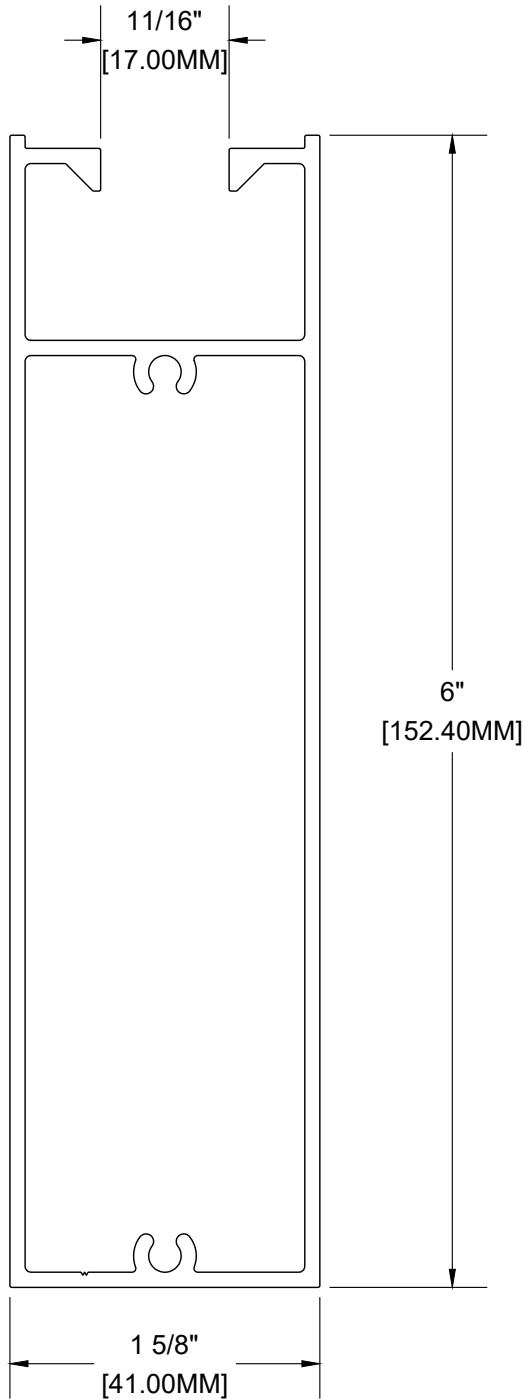



These drawings are published as an information guide only. These CAD drawings are intended as templates to assist the designer, they do not contain the full detail required for construction and must be read in conjunction with the installation instructions on www.longboardproducts.com. You should obtain architectural, engineering or other technical advice to assess the suitability of these drawings to the requirements of your particular project. Mayne Coatings Corp. and Longboard products accepts no liability in respect to the use of these drawings.

For complete installation instructions refer to the appropriate documentation at www.longboardsuppliers.com/installation

6" DAUNTLESS BEAM
ALUMINUM ALLOY: 6063-T5
WEIGHT: 1.57 LBS/ LF
SCALE: 1:1



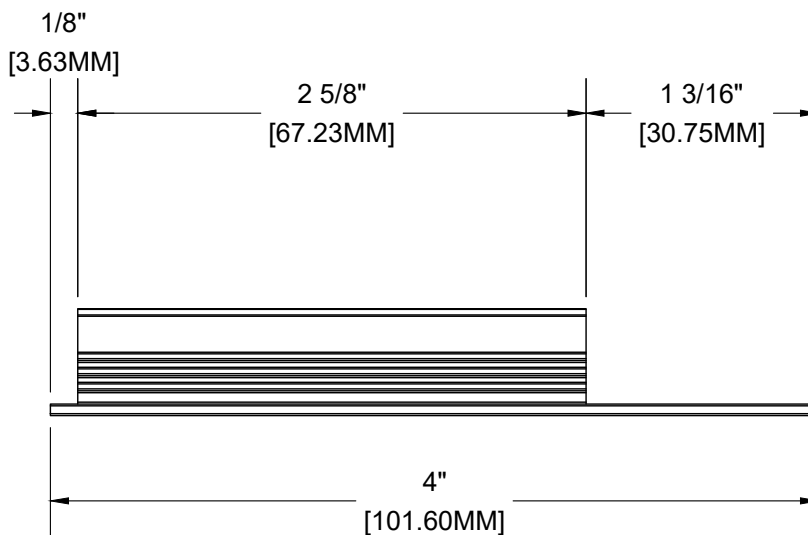
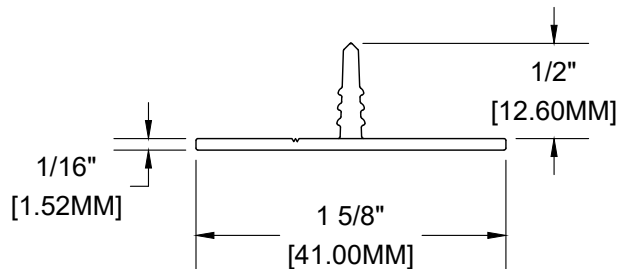

These drawings are published as an information guide only. These CAD drawings are intended as templates to assist the designer, they do not contain the full detail required for construction and must be read in conjunction with the installation instructions on www.longboardproducts.com. You should obtain architectural, engineering or other technical advice to assess the suitability of these drawings to the requirements of your particular project. Mayne Coatings Corp. and Longboard products accepts no liability in respect to the use of these drawings.

For complete installation instructions refer to the appropriate documentation at www.longboardsuppliers.com/installation

4" DAUNTLESS END CAP
 ALUMINUM ALLOY: 6063-T5
 WEIGHT: 0.05 LBS
 SCALE: 1:1



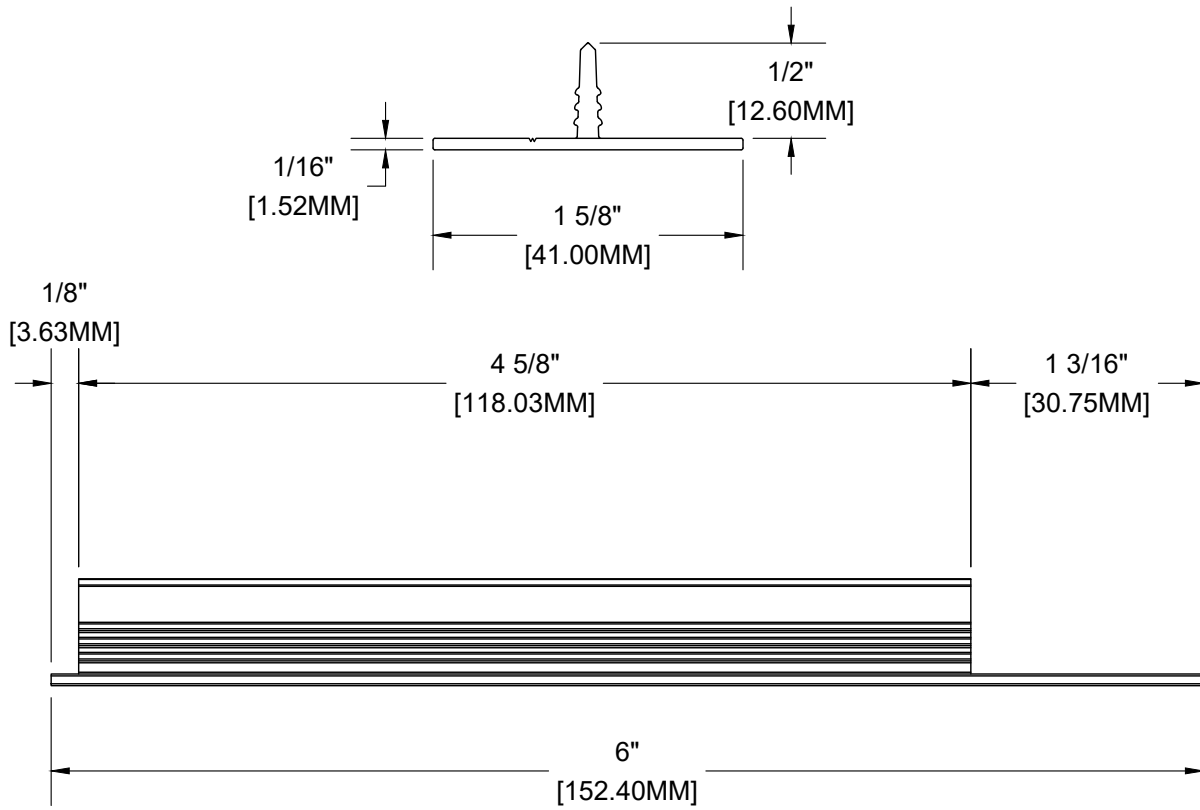

These drawings are published as an information guide only. These CAD drawings are intended as templates to assist the designer, they do not contain the full detail required for construction and must be read in conjunction with the installation instructions on www.longboardproducts.com. You should obtain architectural, engineering or other technical advice to assess the suitability of these drawings to the requirements of your particular project. Mayne Coatings Corp. and Longboard products accepts no liability in respect to the use of these drawings.

For complete installation instructions refer to the appropriate documentation at www.longboardsuppliers.com/installation

6" DAUNTLESS END CAP
 ALUMINUM ALLOY: 6063-T5
 WEIGHT: 0.0785 LBS
 SCALE: 1:1



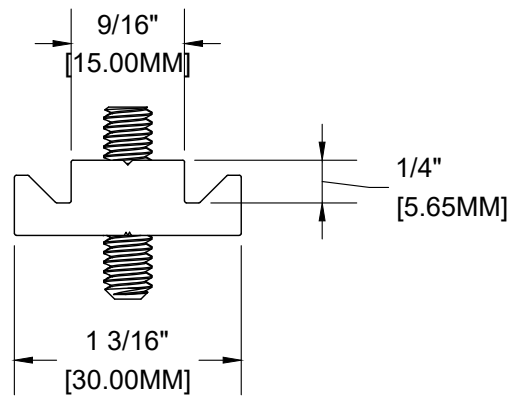
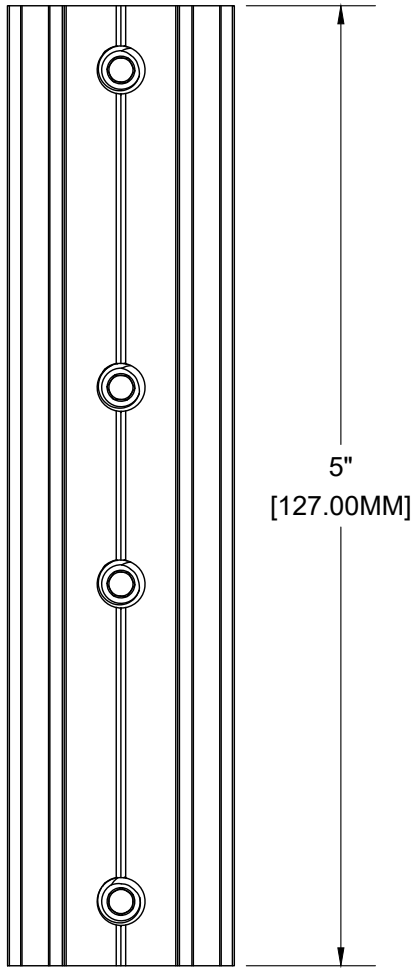

These drawings are published as an information guide only. These CAD drawings are intended as templates to assist the designer, they do not contain the full detail required for construction and must be read in conjunction with the installation instructions on www.longboardproducts.com. You should obtain architectural, engineering or other technical advice to assess the suitability of these drawings to the requirements of your particular project. Mayne Coatings Corp. and Longboard products accepts no liability in respect to the use of these drawings.

For complete installation instructions refer to the appropriate documentation at www.longboardsuppliers.com/installation

SPLINE CONNECTOR
 ALUMINUM ALLOY: 6063-T5
 WEIGHT: 0.124 LBS
 SCALE: 1:1



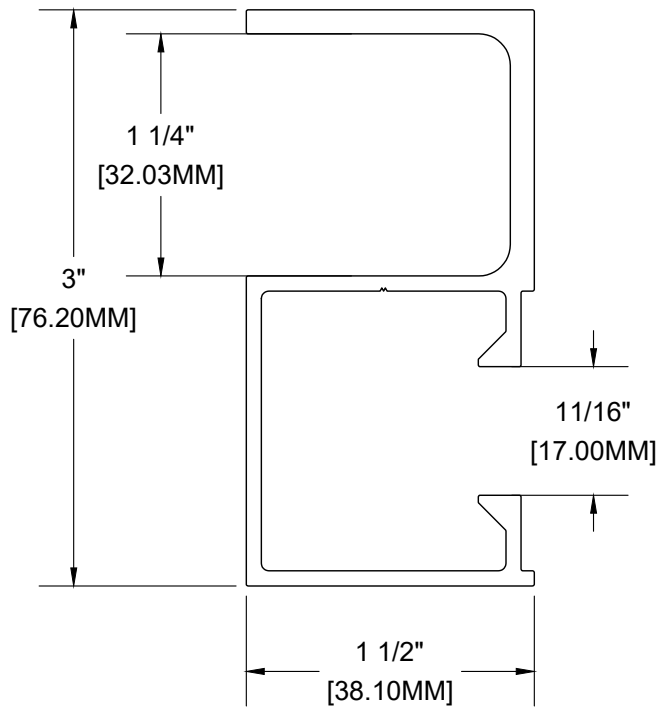

These drawings are published as an information guide only. These CAD drawings are intended as templates to assist the designer, they do not contain the full detail required for construction and must be read in conjunction with the installation instructions on www.longboardproducts.com. You should obtain architectural, engineering or other technical advice to assess the suitability of these drawings to the requirements of your particular project. Mayne Coatings Corp. and Longboard products accepts no liability in respect to the use of these drawings.

For complete installation instructions refer to the appropriate documentation at www.longboardsuppliers.com/installation

SIDE CARRIER RAIL
 ALUMINUM ALLOY: 6063-T5
 WEIGHT: 0.94 LBS/ LF
 SCALE: 1:1



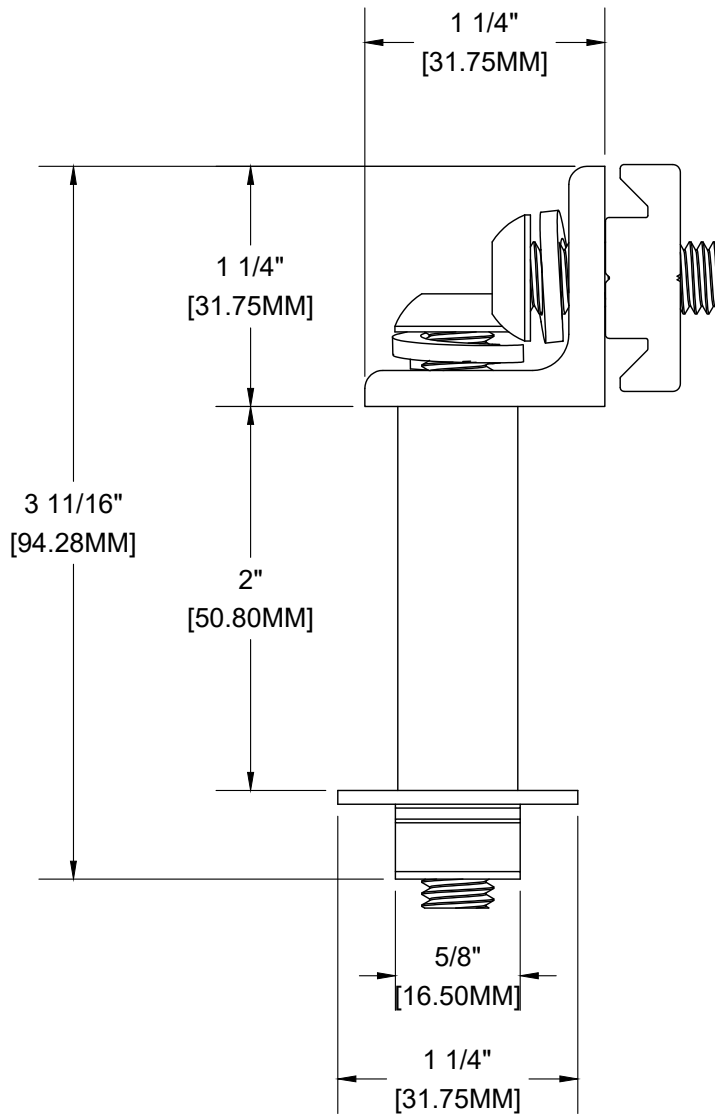

These drawings are published as an information guide only. These CAD drawings are intended as templates to assist the designer, they do not contain the full detail required for construction and must be read in conjunction with the installation instructions on www.longboardproducts.com. You should obtain architectural, engineering or other technical advice to assess the suitability of these drawings to the requirements of your particular project. Mayne Coatings Corp. and Longboard products accepts no liability in respect to the use of these drawings.

For complete installation instructions refer to the appropriate documentation at www.longboardsuppliers.com/installation

HANGER BRACKET 2"
MATERIALS: 6063-T5 ALUMINUM & 304 STAINLESS STEEL
WEIGHT: 0.277 LBS
SCALE: 1:1



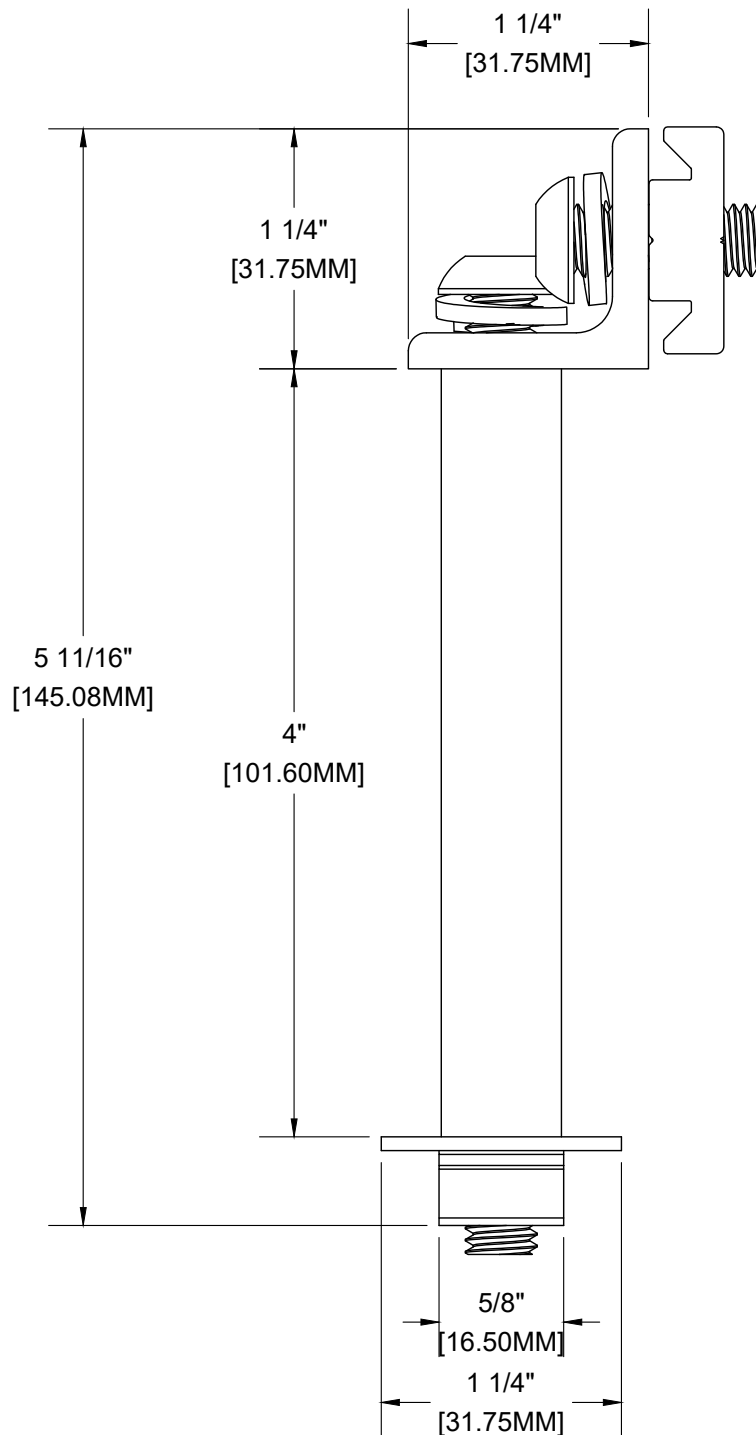

These drawings are published as an information guide only. These CAD drawings are intended as templates to assist the designer, they do not contain the full detail required for construction and must be read in conjunction with the installation instructions on www.longboardproducts.com. You should obtain architectural, engineering or other technical advice to assess the suitability of these drawings to the requirements of your particular project. Mayne Coatings Corp. and Longboard products accepts no liability in respect to the use of these drawings.

For complete installation instructions refer to the appropriate documentation at www.longboardsuppliers.com/installation

HANGER BRACKET 4"
MATERIALS: 6063-T5 ALUMINUM & 304 STAINLESS STEEL
WEIGHT: 0.342 LBS
SCALE: 1:1



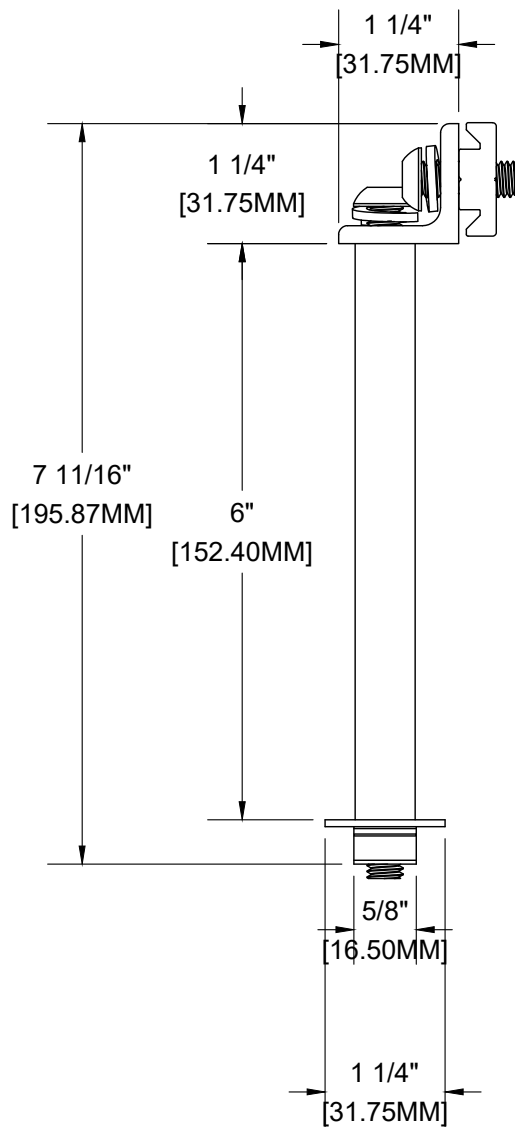

These drawings are published as an information guide only. These CAD drawings are intended as templates to assist the designer, they do not contain the full detail required for construction and must be read in conjunction with the installation instructions on www.longboardproducts.com. You should obtain architectural, engineering or other technical advice to assess the suitability of these drawings to the requirements of your particular project. Mayne Coatings Corp. and Longboard products accepts no liability in respect to the use of these drawings.

For complete installation instructions refer to the appropriate documentation at www.longboardsuppliers.com/installation

HANGER BRACKET 6"
 MATERIALS: 6063-T5 ALUMINUM & 304 STAINLESS STEEL
 WEIGHT: 0.892 LBS
 SCALE: 1:2



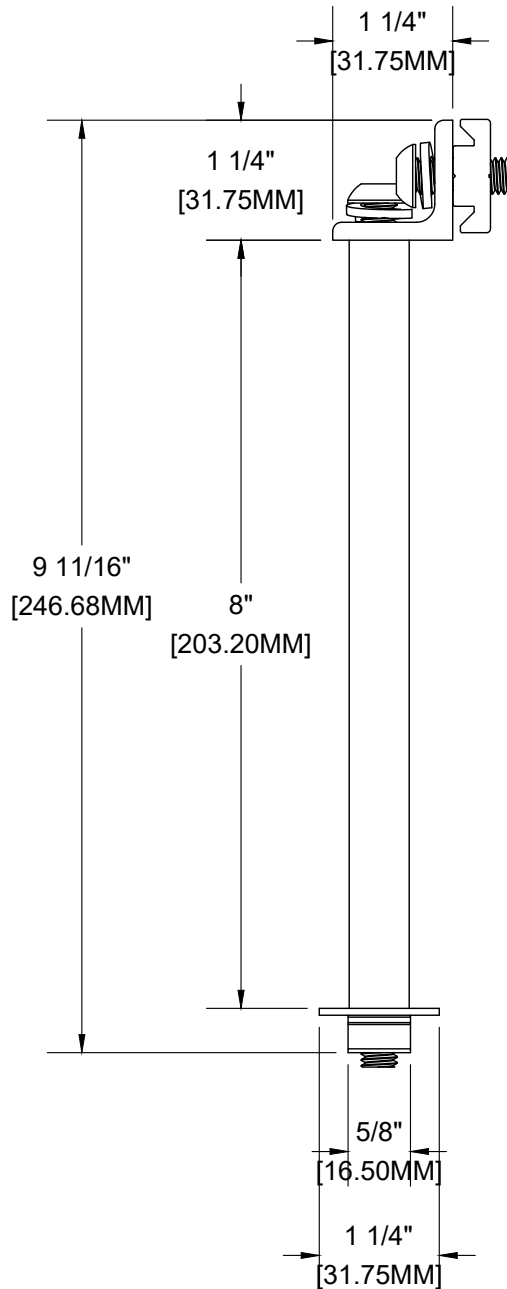

These drawings are published as an information guide only. These CAD drawings are intended as templates to assist the designer, they do not contain the full detail required for construction and must be read in conjunction with the installation instructions on www.longboardproducts.com. You should obtain architectural, engineering or other technical advice to assess the suitability of these drawings to the requirements of your particular project. Mayne Coatings Corp. and Longboard products accepts no liability in respect to the use of these drawings.

For complete installation instructions refer to the appropriate documentation at www.longboardsuppliers.com/installation

HANGER BRACKET 8"
 MATERIALS: 6063-T5 ALUMINUM & 304 STAINLESS STEEL
 WEIGHT: 1.08 LBS
 SCALE: 1:2



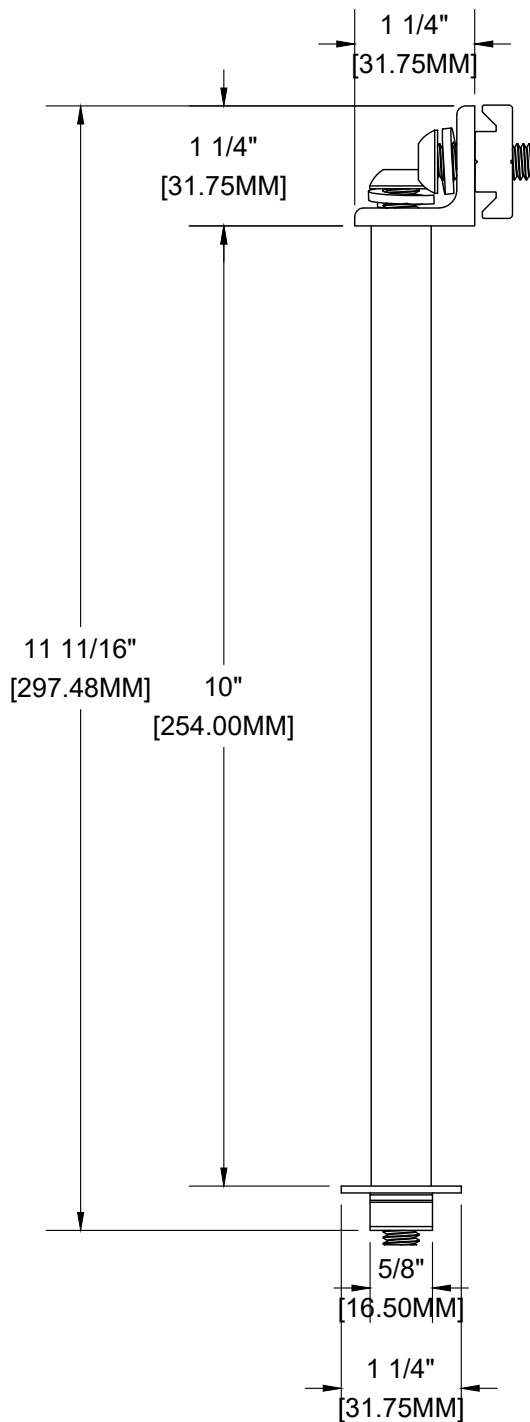

These drawings are published as an information guide only. These CAD drawings are intended as templates to assist the designer, they do not contain the full detail required for construction and must be read in conjunction with the installation instructions on www.longboardproducts.com. You should obtain architectural, engineering or other technical advice to assess the suitability of these drawings to the requirements of your particular project. Mayne Coatings Corp. and Longboard products accepts no liability in respect to the use of these drawings.

For complete installation instructions refer to the appropriate documentation at www.longboardsuppliers.com/installation

HANGER BRACKET 10"
MATERIALS: 6063-T5 ALUMINUM & 304 STAINLESS STEEL
WEIGHT: 1.26 LBS
SCALE: 1:2



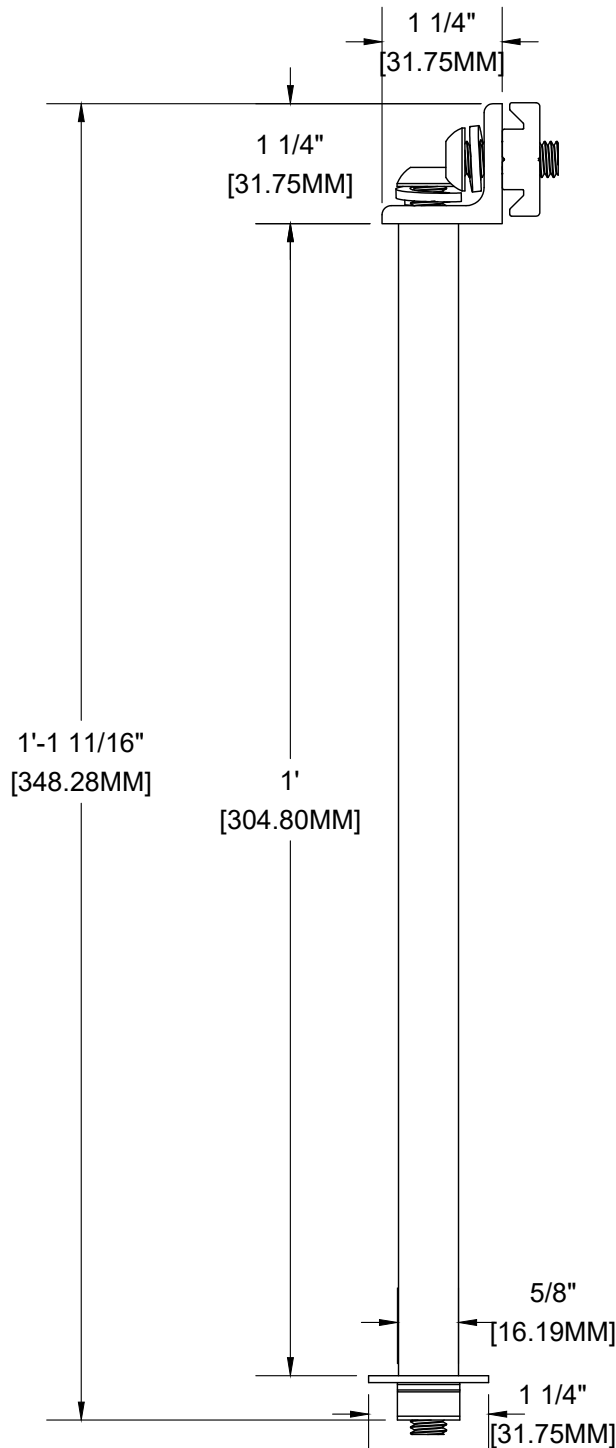

These drawings are published as an information guide only. These CAD drawings are intended as templates to assist the designer, they do not contain the full detail required for construction and must be read in conjunction with the installation instructions on www.longboardproducts.com. You should obtain architectural, engineering or other technical advice to assess the suitability of these drawings to the requirements of your particular project. Mayne Coatings Corp. and Longboard products accepts no liability in respect to the use of these drawings.

For complete installation instructions refer to the appropriate documentation at www.longboardsuppliers.com/installation

HANGER BRACKET 12"
MATERIALS: 6063-T5 ALUMINUM & 304 STAINLESS STEEL
WEIGHT: 1.45 LBS
SCALE: 1:2



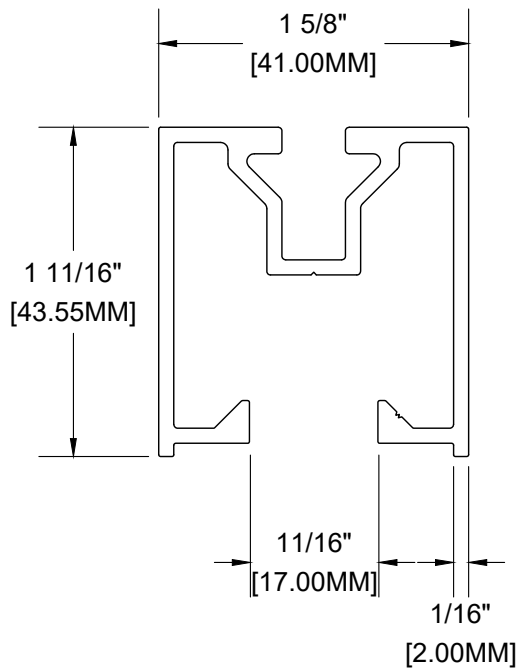

These drawings are published as an information guide only. These CAD drawings are intended as templates to assist the designer, they do not contain the full detail required for construction and must be read in conjunction with the installation instructions on www.longboardproducts.com. You should obtain architectural, engineering or other technical advice to assess the suitability of these drawings to the requirements of your particular project. Mayne Coatings Corp. and Longboard products accepts no liability in respect to the use of these drawings.

For complete installation instructions refer to the appropriate documentation at www.longboardsuppliers.com/installation

SINGLE CARRIER RAIL
 ALUMINUM ALLOY: 6063-T5
 WEIGHT: 0.733 LBS/ LF
 SCALE: 1:1



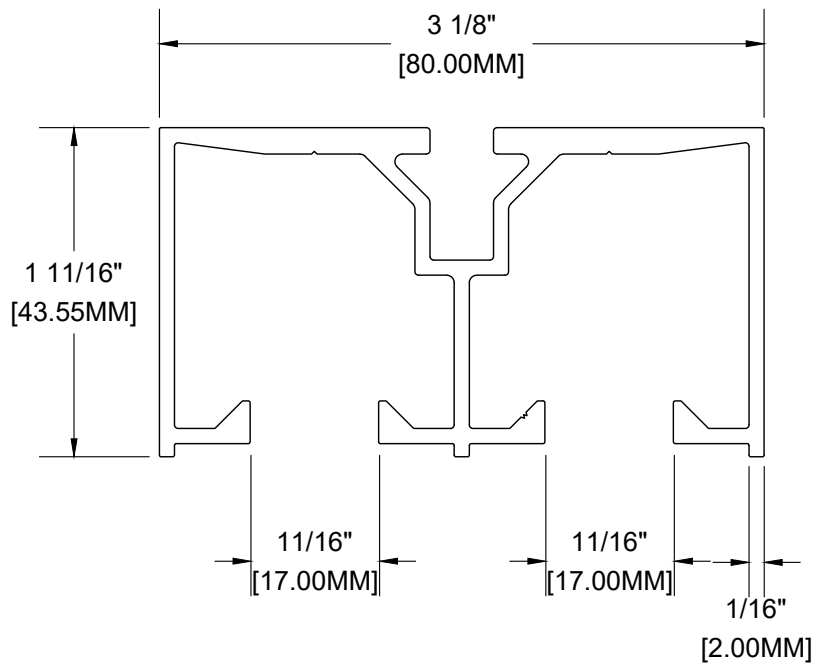

These drawings are published as an information guide only. These CAD drawings are intended as templates to assist the designer, they do not contain the full detail required for construction and must be read in conjunction with the installation instructions on www.longboardproducts.com. You should obtain architectural, engineering or other technical advice to assess the suitability of these drawings to the requirements of your particular project. Mayne Coatings Corp. and Longboard products accepts no liability in respect to the use of these drawings.

For complete installation instructions refer to the appropriate documentation at www.longboardsuppliers.com/installation

DOUBLE CARRIER RAIL
 ALUMINUM ALLOY: 6063-T5
 WEIGHT: 1.189 LBS/ LF
 SCALE: 1:1



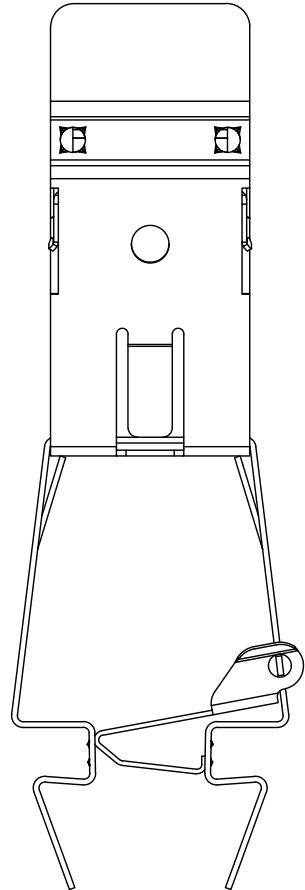
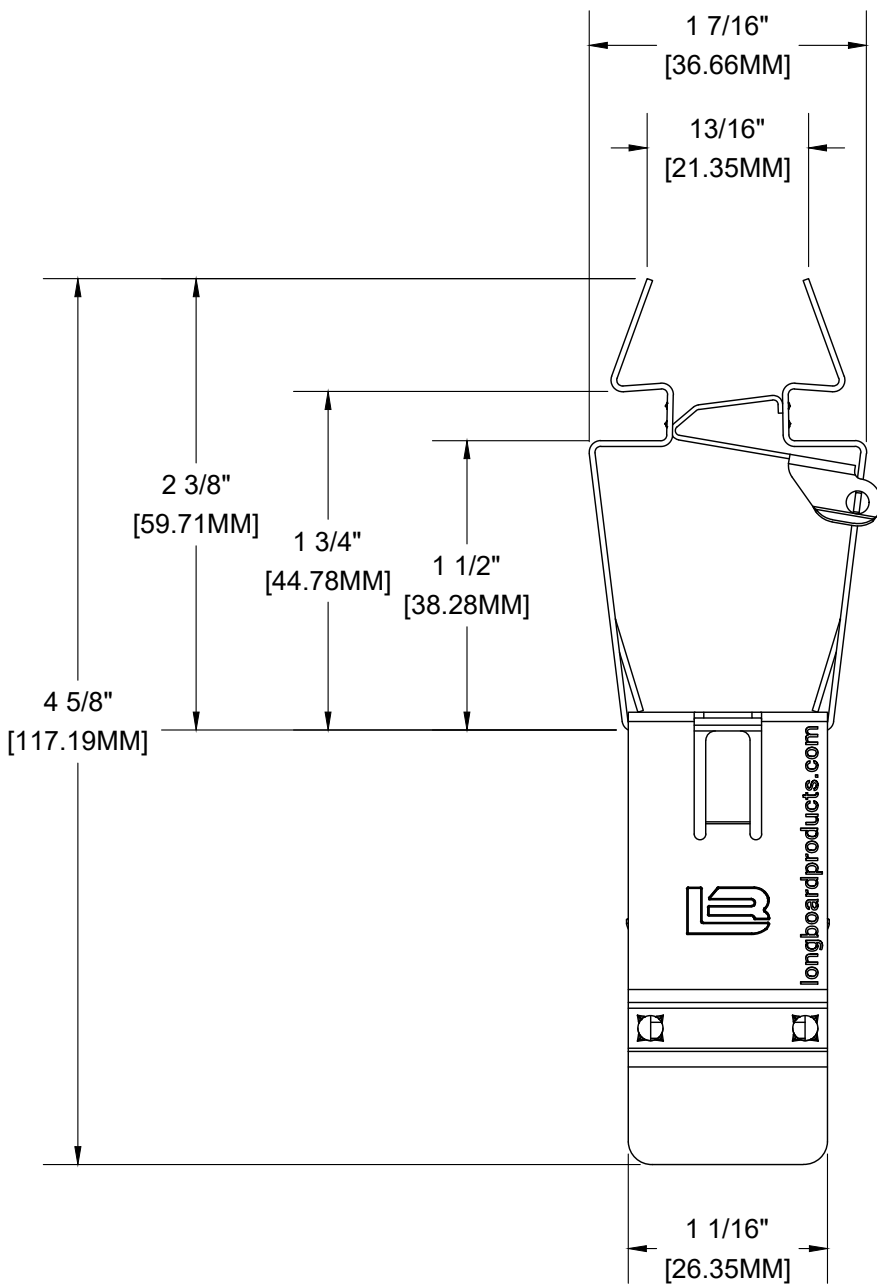

These drawings are published as an information guide only. These CAD drawings are intended as templates to assist the designer, they do not contain the full detail required for construction and must be read in conjunction with the installation instructions on www.longboardproducts.com. You should obtain architectural, engineering or other technical advice to assess the suitability of these drawings to the requirements of your particular project. Mayne Coatings Corp. and Longboard products accepts no liability in respect to the use of these drawings.

For complete installation instructions refer to the appropriate documentation at www.longboardsuppliers.com/installation

HANGER CLIP
 MATERIAL: STAINLESS STEEL
 WEIGHT: 0.070 LBS
 SCALE: 1:1

