

# INTREPID BEAM CEILING SYSTEM

## TYPICAL ISOMETRICS

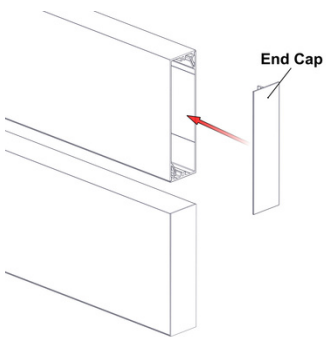

## TYPICAL SECTIONS

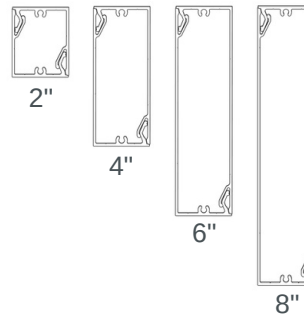
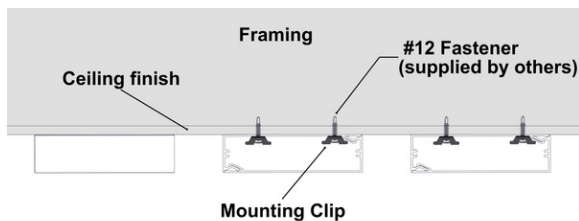

## PROFILES

1-5/8" X 2", 4", 6", 8"  
Standard lengths: 24'

## COMPONENTS

End Caps, Mounting Clips.

## ATTACHMENT

Fasten w. #12 screws\* @ 6' o.c.  
using mounting clips. (\*Not included)  
△ See install guide for details.

## FINISHES

Woodgrains, solid colors, naturally aged metals, special order.  
Custom solid color matching available (additional lead times apply).

## BIM & CAD

RVT & DWG files available, see  
our website for details.

## LEAD TIME

Most Popular Finishes  
-ready to ship within 1 week  
Additional Finishes  
-ready to ship within 14 weeks

## TECHNICAL SPECIFICATIONS

### PHYSICAL DATA

6063-T5 Extruded Aluminum  
100% Recyclable  
Warranty: Finish:15 year (standard)/20 year\* (ultra) (\*10 week lead time);  
Aluminum: 50 year  
Weight (lbs/lf): 0.93 (2"); 1.3 (4"); 1.5 (6"); 1.9 (8")

### TESTING

ICC-ESR 4183 Evaluation Report - Division: 05 00 00 - METALS  
• Section: 05 50 00 - Metal Fabrications  
CAN/ULC S102  
CAN/ULC S114

LARR - Los Angeles Department of Building Safety (LADBS) accepts ICC-ES reports as proof of compliance

WUI (The Wildland-Urban Interface) – California Department of Forestry & Fire Protection Office of the State Fire Marshal Listing No. 8140-2286:0500



**Fire Rating:** Class A Non-Combustible by ASTM E136 & ASTM E84



**Acoustical Rating with insulation:** NRC up to 0.80



**Light reflectance (LRV):** Up to 73.2% (Ultra White)



[info@longboardproducts.com](mailto:info@longboardproducts.com)  
[longboardproducts.com](http://longboardproducts.com)  
800 604 0343



**LONGBOARD**<sup>®</sup>  
ARCHITECTURAL PRODUCTS

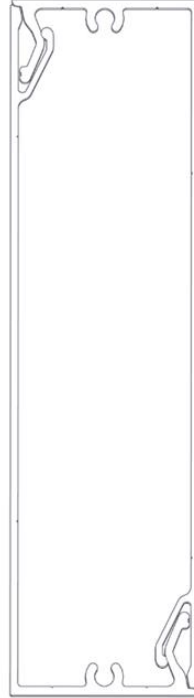
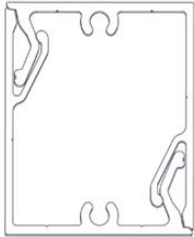

# Link & Lock Intrepid

Installation Guidelines

## Table of Contents

<b>Material Specifications</b>	<b>3</b>
Finishes	3
Expansion and contraction	3
Material ordering and deliveries	3
Storage and handling	3
Cleaning	3
Warranty	3
Graffiti Removal	4
<b>Components</b>	<b>5</b>
Components (Typical)	5
<b>Tools/Cutting/Fastening</b>	<b>6</b>
Tools	6
Cutting	6
Fastening	7
Fastener types	7
Framing requirements	8
<b>System Install</b>	<b>9</b>
Install details	9
Typical dimensions	9
System layout & Install steps	10
Perimeter and field area limitations	10
Preparation drilling for Install	11
Butt-Joints & Lap Joints	12
Batten orientation	13
Fin orientation	14
End to End orientation	15-16
Large spans with Stiffener	17-19
<b>Appendix</b>	<b>20</b>
Tables - Expansion & contraction	20
Tables – Allowable attachment span	21
Sound Absorption (NRC & SAA)	22
Handling and care of products	23
Contact Info	24

## Material Specifications

### Finishes

- Longboard Products are available in a wide range of powder coated finishes
- Custom solid colors are available upon request

All Longboard Products are produced 1" (25mm) oversized, as one end is drilled for the coating process and both ends have 1/2" (12mm) of masking tape (woodgrains only) which must be cut off for best results.

### Expansion & Contraction

Although interior applications likely will not experience temperature change, it is good practice to follow the standard attachment procedure described in this guide. See **Appendix for Tables 1 & 2, expansion/contraction calculations per foot/meter of material.**

### Material Ordering & Delivery

- |              |   |
|--------------|---|
| • Packaging: | Link & Lock is sold by the set (pair) and in widths of 2", 4", 6", 8"<br>End caps are sold by the box: 20 caps/bx<br>End Mounts are sold by the box: 20 mounts/bx<br>Stiffener is sold in 24' lengths (includes Double-sided Tape)  |
| • Shipping:  | Lead time is 3-6 business days* + shipping ( <i>*subject to change</i> ), delivered on 24' (7.3m) long skids weighing up to 2000 lbs. A mechanical lift with forks is required on site to receive the order.  |
| • QC:        | Always inspect the delivery for damage and contact LB ASAP if there are any issues: <a href="mailto:info@longboardproducts.com">info@longboardproducts.com</a> or 1-800-604-0343 and include your PO# and any pictures if possible. Mark the delivery receipt as "damaged" and accept the delivery as-is. Longboard is not responsible for the installation of blemished or damaged material. |

### Storage & Handling

Be sure to store the material flat, keep it dry, safe & secure and remain in unopened cartons until ready to be installed. See **Appendix for proper handling and care instructions.**

### Cleaning Recommendations

- Initial and periodic cleaning for best looking product
- Basic methods use a combination of moderate water pressure, soft sponge/brush and a mild detergent (Safe for your hands, safe for the product)

**⚠ NEVER** use aggressive acid or alkaline cleaners on Longboard finishes. Do not use cleaners containing Trisodium Phosphate, Phosphoric Acid, Hydrochloric Acid, Hydrofluoric Acid, Fluorides, or any other compound that is known to react with metal.

**\*See *Cleaning Guide for full requirements & cleaning schedule:***  
[longboardproducts/resources/care-maintenance.com](http://longboardproducts/resources/care-maintenance.com)

### Warranty

Upon substantial completion of the project, register for warranty online here: [longboardproducts.com/warranty](http://longboardproducts.com/warranty)

**⚠** Registration is required for the warranty to be in effect.

## Graffiti Removal

**Standard Woodgrain**  
 Use Standard soap & water only

**D2000 Solid Color**

	Prosoco Cleaner	MEK Solvent
Permanent Marker	<input checked="" type="checkbox"/>	<input checked="" type="checkbox"/>
Oil Based Spray Paint	<input checked="" type="checkbox"/>	<input checked="" type="checkbox"/>
Water Based Spray Paint	<input checked="" type="checkbox"/>	<input checked="" type="checkbox"/>
Adhesive Tape	<input checked="" type="checkbox"/>	<input checked="" type="checkbox"/>

MEK Solvent

Prosoco Anti-Graffiti Cleaner

**SPECIAL ORDER - EXT. LEAD TIMES CONTACT LB**

**Anti-Graffiti High Gloss Woodgrain**

	MEK Solvent
Permanent Marker	<input checked="" type="checkbox"/>
Oil Based Spray Paint	<input checked="" type="checkbox"/>
Water Based Spray Paint	<input checked="" type="checkbox"/>
Adhesive Tape	<input checked="" type="checkbox"/>

MEK Solvent

Note: Cleaning the surface with a cleanser that is not diluted as per instructions, may result in damage to the coating.

## Components

### Components (Typical)







The Link & Lock system consists of two (2) matching L-shaped extrusions, snapped together to make a complete set. For all LB components go to [longboardproducts.com](http://longboardproducts.com).

 <p><b>2" Link &amp; Lock</b> (1 5/8" width) 2X2LL.289</p>	 <p><b>4" Link &amp; Lock</b> (1 5/8" width) 2X4LL.289</p>	 <p><b>6" Link &amp; Lock</b> (1 5/8" width) 2X6LL.289</p>	 <p><b>8" Link &amp; Lock</b> (1 5/8" width) 2X8LL.289</p>
 <p><b>1/2" Pilot Point Drill Bit</b> DRILLBT.05</p>	 <p><b>Paint Pen</b> TUP</p>	 <p><b>End Cap</b> 2LLEC.2,4,6,8</p>	 <p><b>Mounting Clip</b> Included with order for 6" O.C. attachment. Additional Clips purchased separately (48 pcs/box) LLMC</p>
 <p><b>2" L&amp;L End Mount</b> 2LLEM.2</p>	 <p><b>4" L&amp;L End Mount</b> 2LLEM.4</p>	 <p><b>6" L&amp;L End Mount</b> 2LLEM.6</p>	 <p><b>8" L&amp;L End Mount</b> 2LLEM.8</p>
 <p><b>Double-sided Tape</b> LLTAPE.1296</p>	 <p><b>Internal Stiffener</b> -Comes Powder Coated Black -Stiffener not available for 2" L&amp;L LLSTIFF.289</p>		

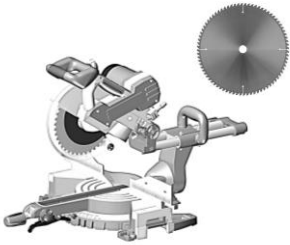
## Tools/Cutting/Fastening

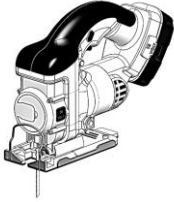
### Tools

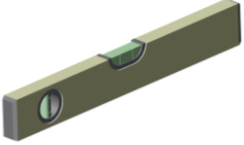
Commonly used tools for Link & Lock install.

			
Table Saw with Carbide Metal Blade Non-ferrous 60-80T (for cutting aluminum)	Miter Saw with Carbide Metal Blade Non-ferrous 60-80T (for cutting aluminum)	Cordless Drill with clutch	Jig Saw (for protrusions)
			
Rubber Mallet (or Hammer)	Level	Hole Saw (for lighting fixtures)	Quick Grip Bar Clamp

### Cutting

⚠ Always be sure to wear appropriate PPE: eye & hearing protection.

Cut battens using a Miter Saw and Table Saw always allowing for expansion & contraction. Trim the taped/drilled ends of all stock length material by at least **1/2" (12mm) each end** and discard.

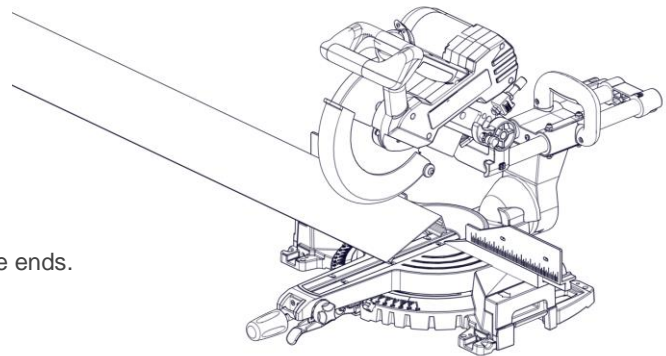

⚠ **DO NOT** Install Link & Lock without trimming the ends.

### Fastening

Longboard Link & Lock consists of two (2) matching L-shaped extrusions, snapped together to make a complete set. The back “L” is mechanically fastened to the substrate, using Longboard **Mounting Clips** fastened typically every **6-8’ O.C.** up to **12ft** with #12 sharp-point screws (for wood substrates) or self-drilling (for metal substrates). The Mounting Clips are included in the order for 6’ spacings.

Fasteners must be corrosion resistant and comply with all local building codes.

⚠ All fasteners should be suitable for exterior use and be compatible with the substrate type. **Fasteners should be anchored into a solid secure substrate.**

Layout and predrill the back “L” at all fastener locations.  
Refer to **Preparation drilling for Install** for hole dimensions and further details.

⚠ See **Appendix** for project specific fastener spacing:  
**Allowable Span - Tables 3-4**

### Fastener types

**RECOMMENDED**

**Pan-Head    Rounded-Head Self-Drilling    Flanged Hex Head**



### Mounting Clip

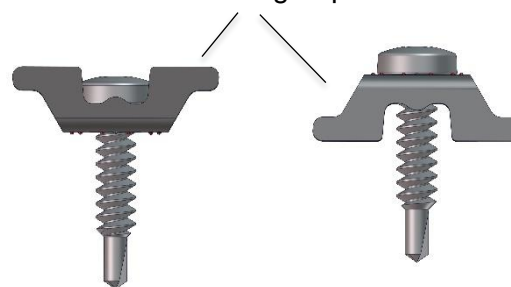

Batten (flat orientation)      Fin orientation

Fastener Types for End Mounts		
End Mount	Pan Head	Hex Head
2"	#10	
4"	#12	#12
6"	#12	#12
8"	#12	#12

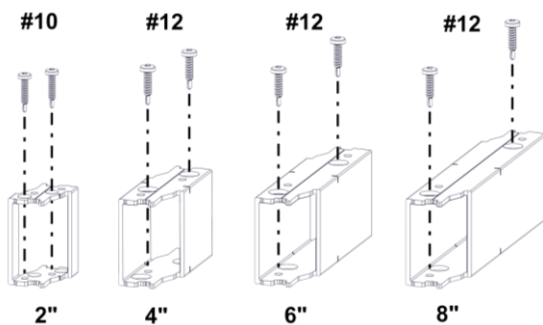

**DO NOT USE**

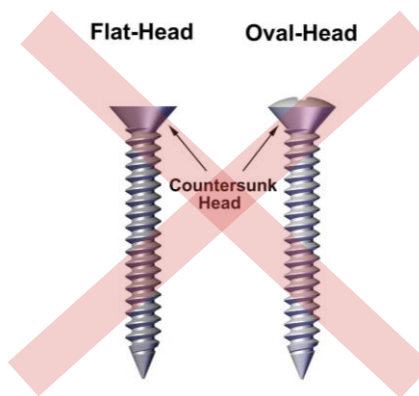



### **Framing requirements**

Always consult your local building authority and follow local building code requirements. See Typical dimensions for sizes and weights of the L&L system.

#### **Wood Framing**

- Size: 2x4 minimum

#### **Metal Framing**

- Gauge: 18 ga. minimum

#### **Concrete/CMU**

Wood or metal furring is recommended over concrete and CMU.

##### Wood Furring:

- Size: 2x2 minimum
- Type: Pressure treated lumber

##### Metal Furring:

- Size: 18 ga. minimum
- Type: Hat channel, Stud, or Z-Girt.

## System Install

### Install details

#### Typical dimensions

- Longboard Link & Lock system typical dimensions:

L&L	Width	Depth	Length	Weight(lbs/ft) *per set
2"	2" (50.8mm)	1 5/8" (41.3mm)	24'	0.93
4"	4" (101.6mm)	1 5/8" (41.3mm)	24'	1.3
6"	6" (152.4mm)	1 5/8" (41.3mm)	24'	1.6
8"	8" (203mm)	1 5/8" (41.3mm)	24'	1.9

- It is good practice to leave a 1/4" (6mm) gap between every component joint or 24' (7.3m) to allow for expansion & contraction. Consider the joints where components meet each other to dictate which component is installed first (eg: right angle butt joints, mitered joints etc.).
- Mounting Clips allow for movement of the battens, to expand & contract during thermal changes.
- Fasten Mounting Clips every 6-8' typical (based on load requirements), alternating from top to bottom for battens using die lines for guides.

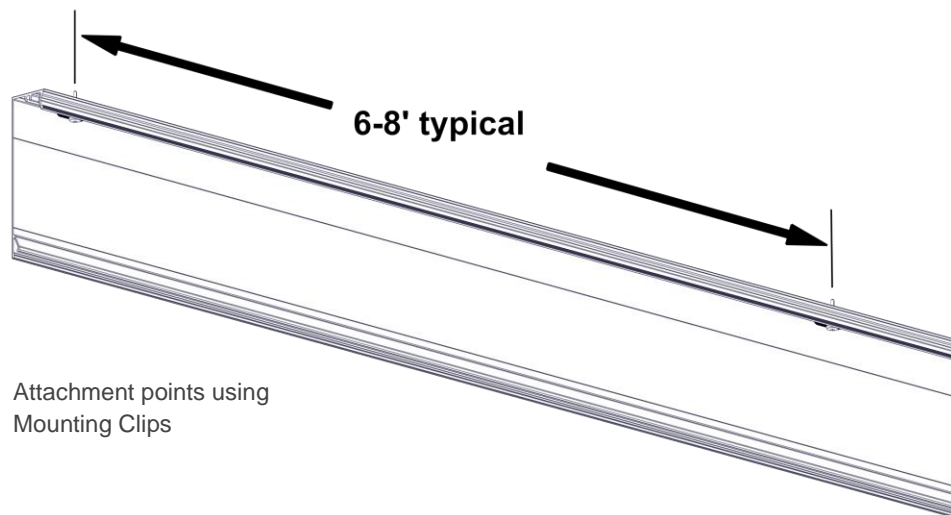

## System layout and Install steps

### Perimeter and field area limitations

Measure and layout your wall area to consider Link & Lock alignment with fixtures, penetrations, and adjacent walls, for desired appearance. The same methodology applies for vertical installations.

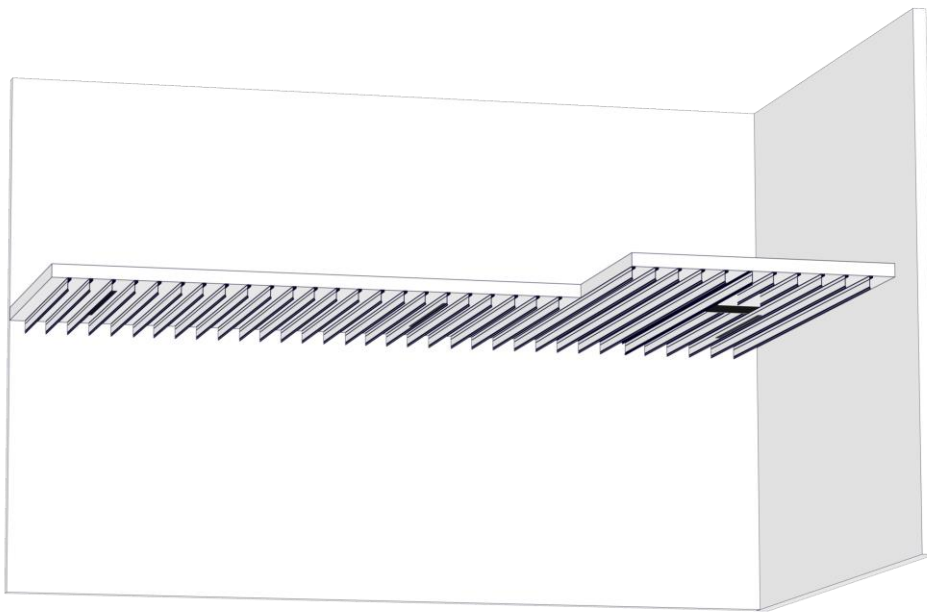
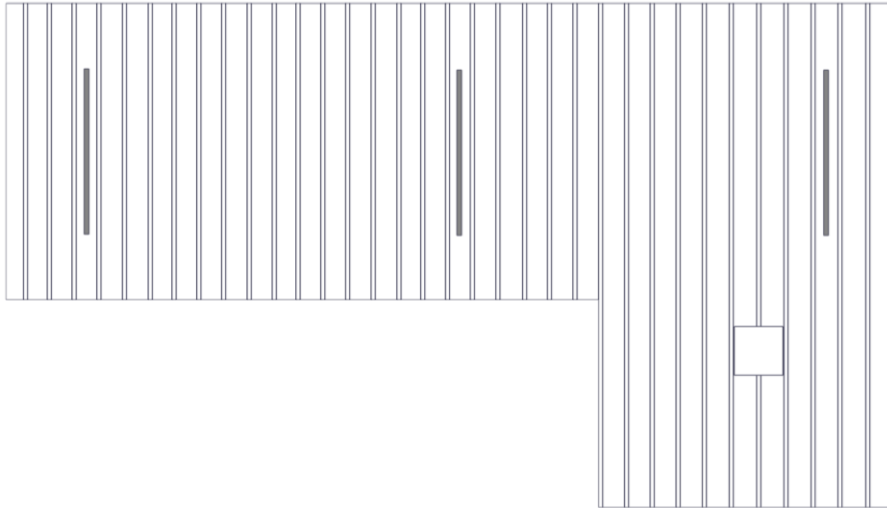

Preparation drilling for Install

To prepare Link & Lock for install, layout and predrill the back "L" with 1/2" holes every 6-8' O.C. typical, with the first hole 2" in from the end to allow space for the End Cap.

For the Batten orientation, alternate the holes from top to bottom using the Dielines for guides.

For Fin orientation, use Pilot Point Drill Bit (see below) as recommended for ease of drilling.

Note: To hard fasten 1 location per length, omit the drilled hole at that location and use for hard fastening.

See **Appendix for project specific fastener spacing:**

**Allowable Span - Tables 3-4**

**⚠ Tip:** Add weep holes as good practice to allow any potential moisture to escape.

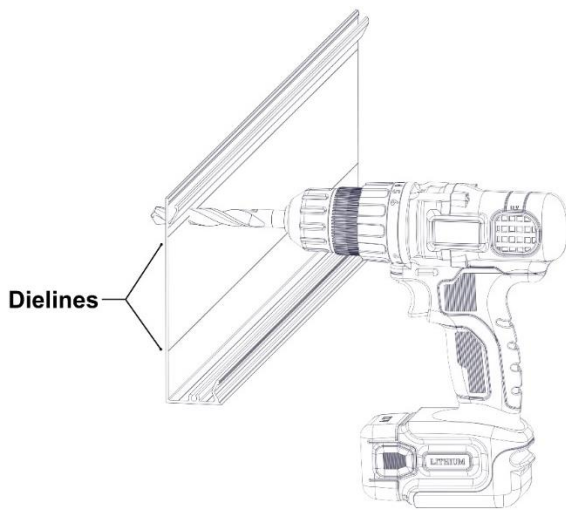
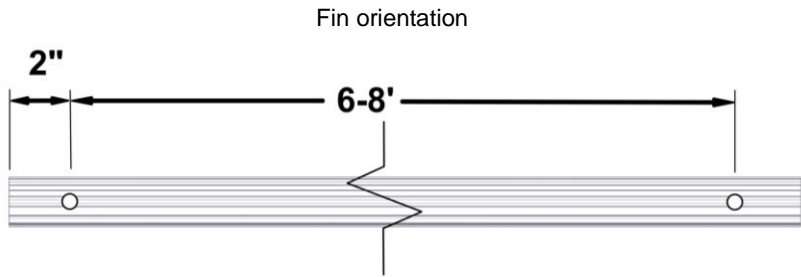
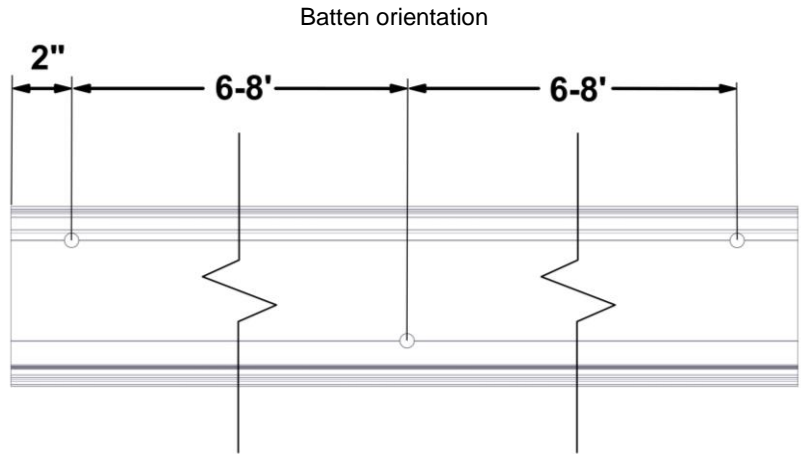

Back "L"

1/2" Pilot Point Drill Bit

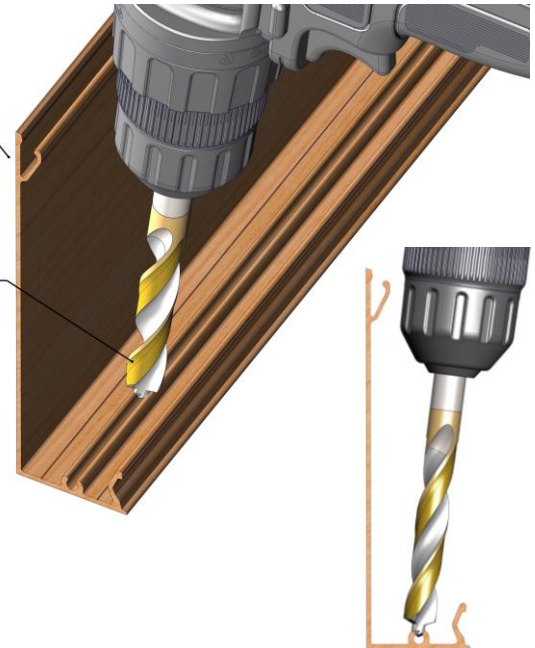

## Butt-Joints & Lap Joints

- **⚠ BUTT-JOINTS.** When installing butt-joints, ensure to leave a 1/4" (6mm) min. gap. every 24' (7.3m) min. (**See Detail A**). Fasteners should be anchored into a solid secure framing member, blocking, furring strip, or backer plate, etc.
- **⚠ LAP-JOINTS.** When installing lap-joints, ensure to leave a 1/4" (6mm) min. gap. every 24' (7.3m) min. (**See Detail B**). Fasteners should be anchored into a solid secure framing member, blocking, furring strip, or backer plate, etc.
- Use touch-up paint pens (purchased separately) to finish the ends at the butt-joint or lap-joint.
- It is good practice to hard-fasten each back "L" at one point per length typically near the center, to keep the battens from migrating.
- DO NOT hard-fasten more than one (1) location per batten.

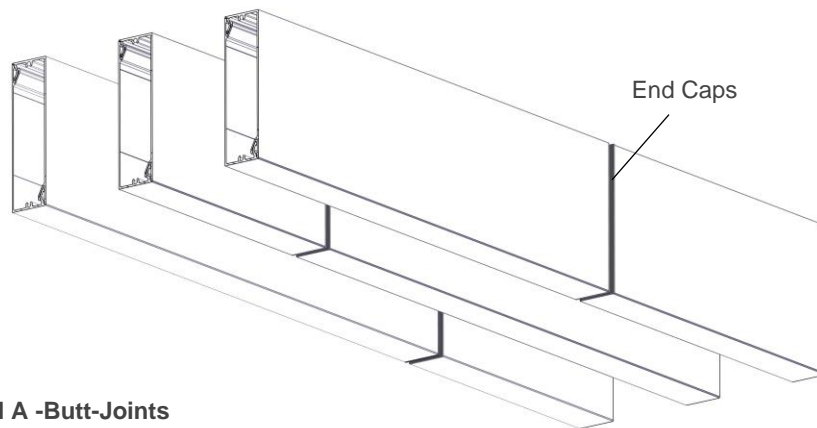

**Detail A -Butt-Joints**

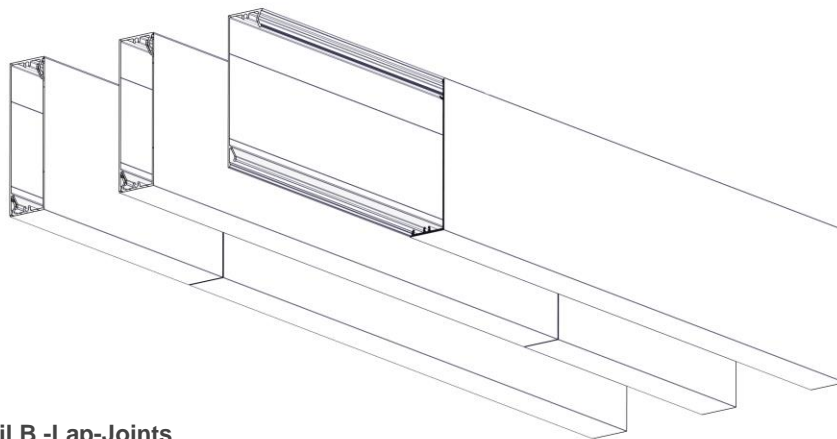

**Detail B -Lap-Joints**

Install Batten orientation

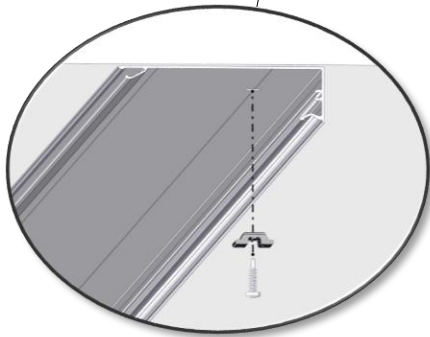
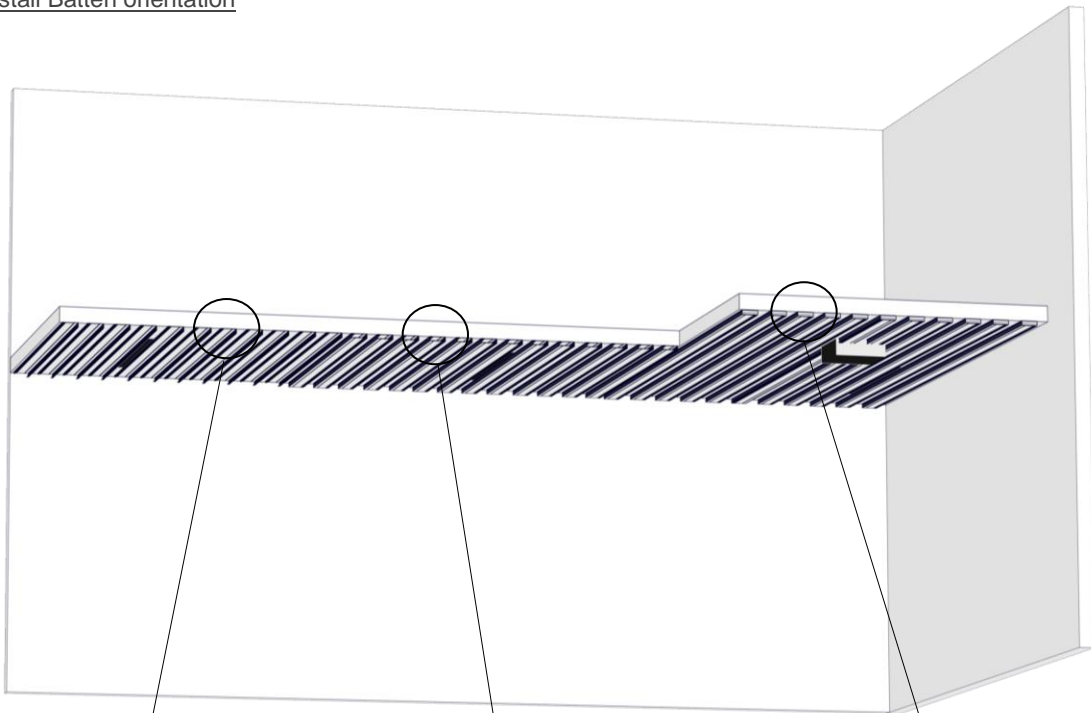

**Step 1**  
Install back "L" using #12 Fasteners and Mounting Clips every 6-8' O.C. typical.

Note: Be sure to fasten in the center of the 1/2" holes to allow for movement each way. Hard fasten near the center of each length to prevent migration of the material over time.

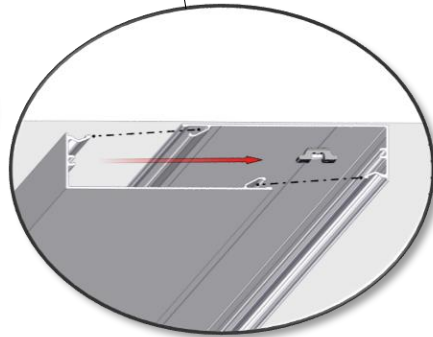

**Step 2**  
Install front "L" and snap it into place, aligning it with ends and joints.

If necessary, use a rubber mallet or hammer and block to protect the finish.

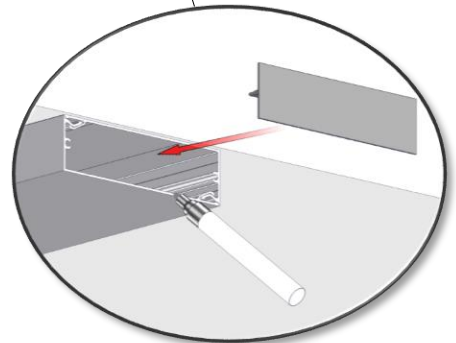

**Step 3**  
Install End Caps, which are friction fit, by pressing them into place using the palm of your hand. If necessary, use a rubber mallet to snap them into place. If required, touch up the cut ends with matching paint pen.

Install Fin orientation

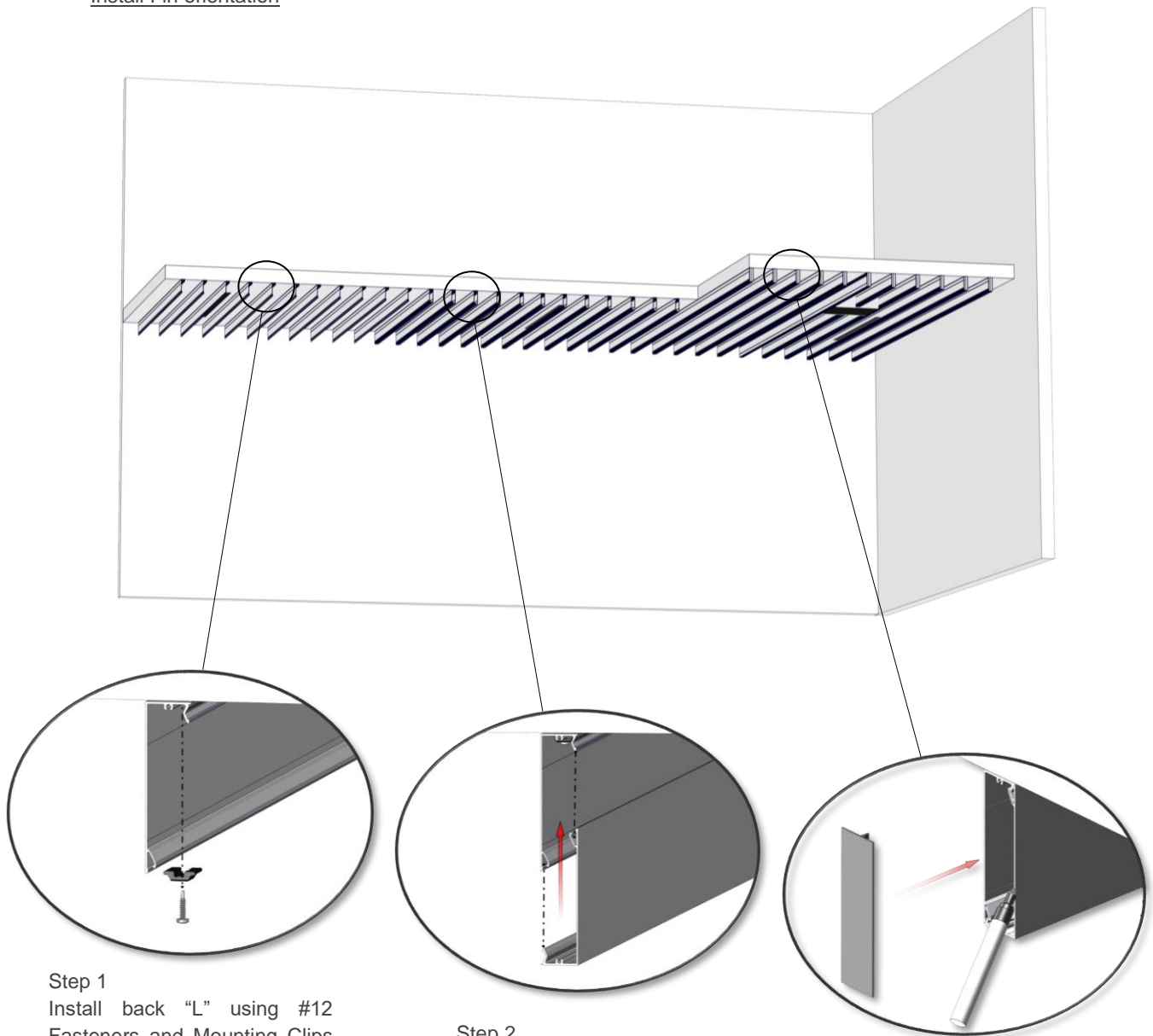

**Step 1**

Install back “L” using #12 Fasteners and Mounting Clips every 6-8’ O.C. typical.

Note: Be sure to fasten in the center of the 1/2” holes to allow for movement each way. Hard fasten near the center of each length to prevent migration of the material over time.

**Step 2**

Install front “L” and snap it into place, aligning it with ends and joints.

If necessary, use a rubber mallet or hammer and block to protect the finish.

**Step 3**

Install End Caps, which are friction fit, by pressing them into place using the palm of your hand. If necessary, use a rubber mallet to snap them into place. If required, touch up the cut ends with matching paint pen.

Install End to End orientation

Note: Use Tables 3-4 in Appendix for Allowable Span for loading.

Step 1

Place End Mounts into position at the top and bottom of the install. It is good practice to check your installation every 2-3 rows for level/plumb and flat/straight, for best results.

Fastener Types for End Mounts		
End Mount	Pan Head	Hex Head
2"	#10	
4"	#12	#12
6"	#12	#12
8"	#12	#12

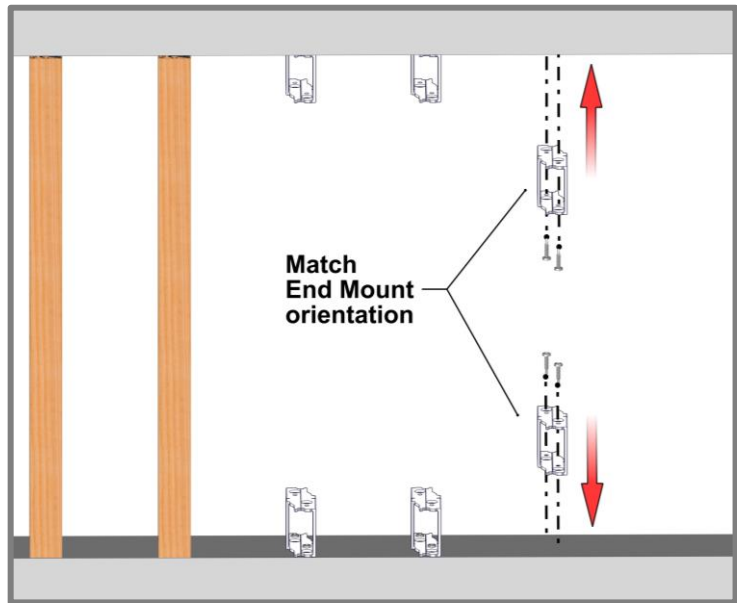

Step 2

Install the End Mounts using #12 Fasteners (#10 for 2" End Mount). Make sure to match the orientation of the End Mounts so the Link & Lock set matches on the top and the bottom. See above for **Fastener Types for End Mounts**.

**▲ TIP:** Check the position of the End Mounts once installed to allow a plumb and straight look.

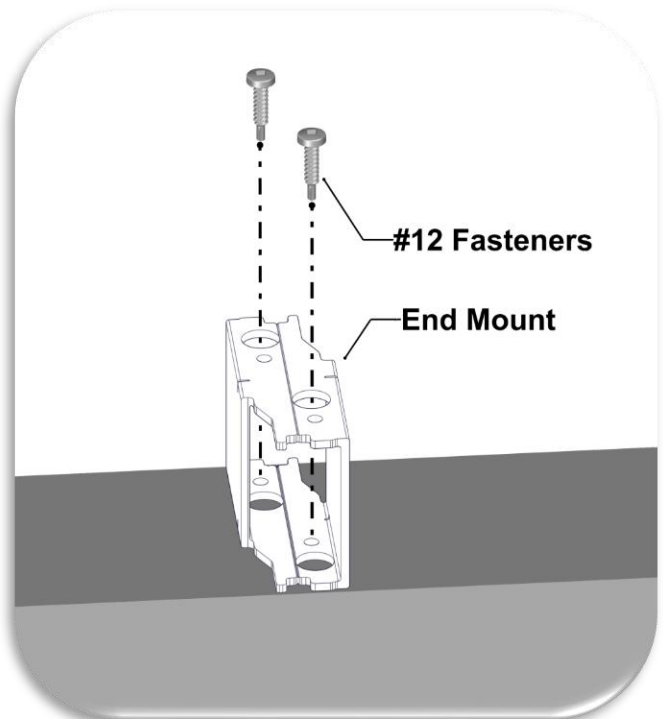
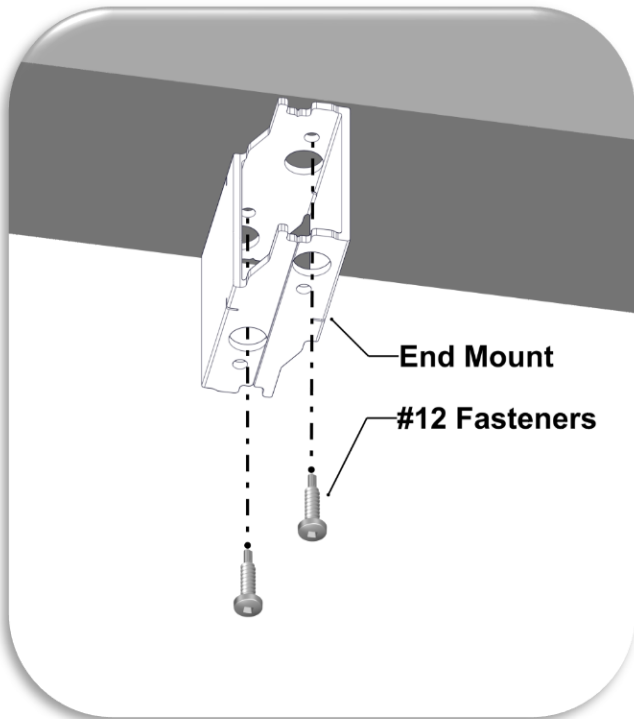



**Step 3**

Measure, cut and install Link & Lock Set and snap it into place onto the End Mounts. Use clamps with rubber pads as common practice to securely snap the front “L” onto the back “L”. If necessary, use a rubber mallet or hammer and block to protect the finish.

**⚠ TIP:** When measuring the Link & Lock, make sure to leave a gap (~1/4”) for expansion and building movement.

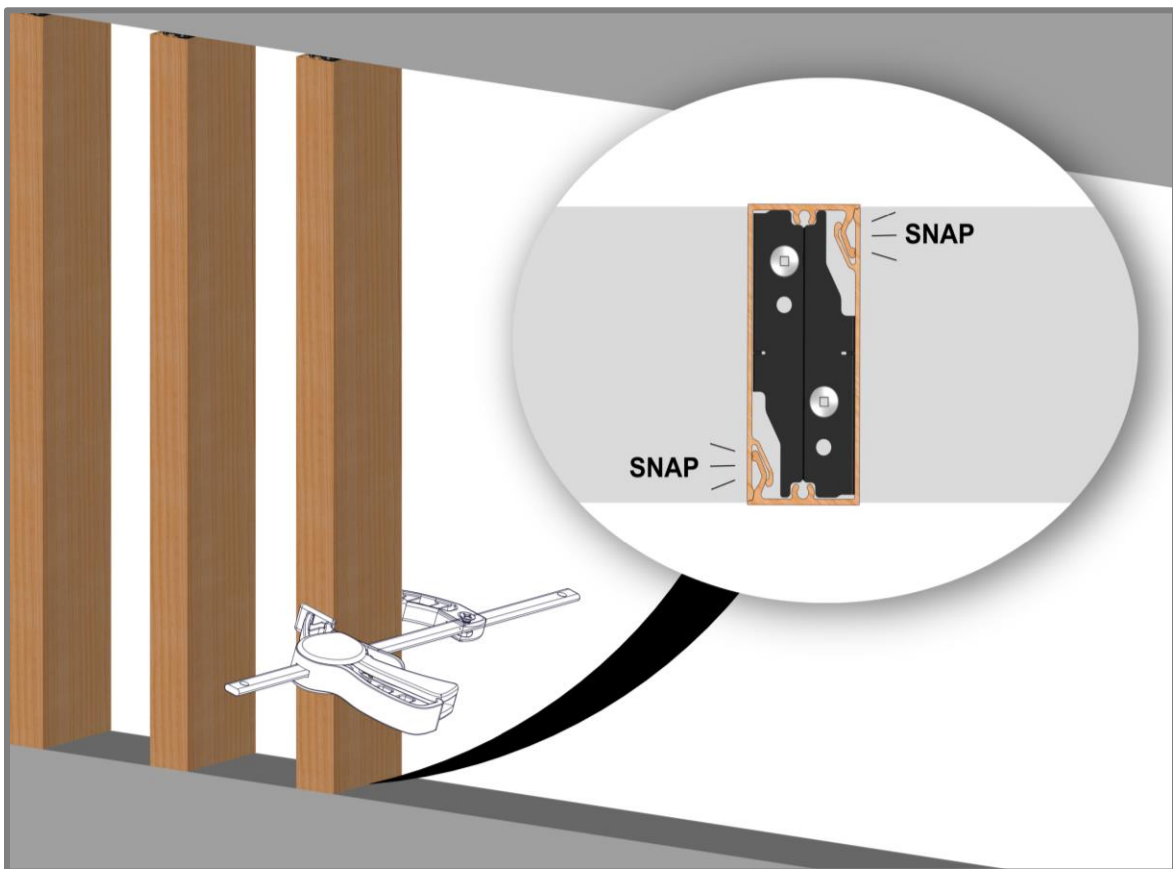
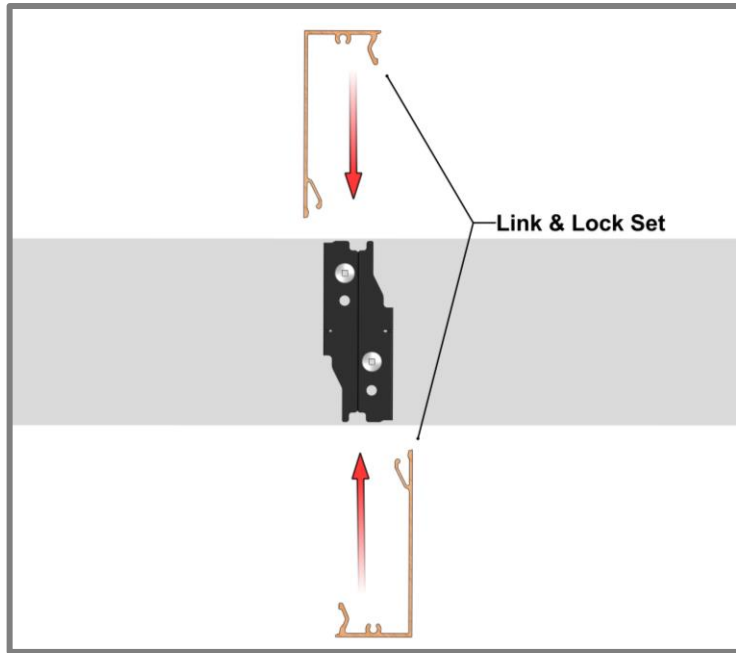
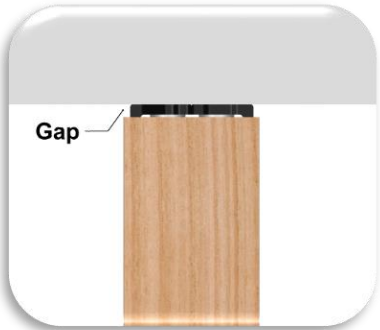

### Large spans with Internal Stiffener

Requirements for large spans:

- Two Mounting Clips with #12 fasteners are used at both ends with a minimum distance apart of 5" O.C.
- An Internal Stiffener is added to reinforce the Link & Lock set for spans up to 12' max @30psf.
- Stiffener must be one continuous member from attachment to attachment.
- Double-sided Tape is used to place the Stiffener onto the Link & Lock. The tape is placed on the center of the Stiffener and then pressed onto far end of the back "L" as shown on page 18.



See **Appendix for allowable spans for project specific load.**

**Allowable Span - Tables 3-4**

#### Step 1

Place predrilled Link & Lock back "L" into position (Drilling page 11). It is good practice to check your installation every 2-3 rows for level/plumb and flat/straight, for best results.

#### Step 2

Install back "L" using #12 Fasteners and Mounting Clips at end attachment points with a minimum distance apart of 5" O.C.

Note: Be sure to fasten in the center of the 1/2" holes to allow for movement each way. Hard fasten one end of each length to prevent migration of the material over time.

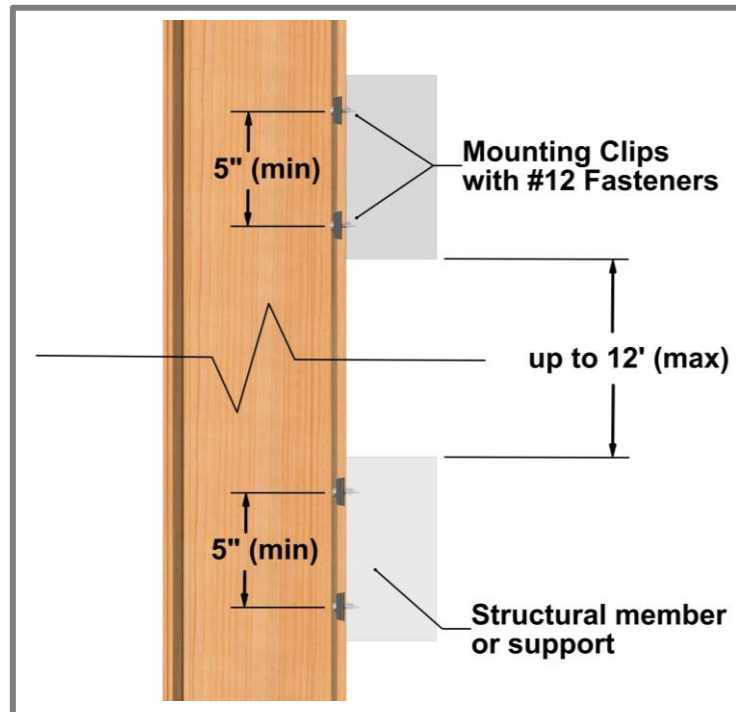

**Step 3**

Peel and place the Double-sided tape onto the back of the Stiffener O.C. Peel the second side and install the Stiffener as shown in the image pressing down to adhere to the tape.

Note: Install Stiffener 1" (min) from the end of the L&L to allow space for the End Cap as seen below.

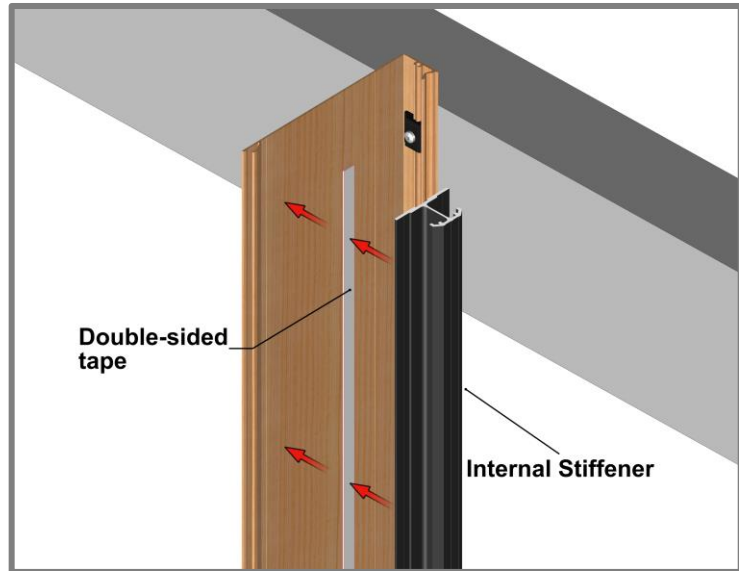

Make sure the Stiffener is located at the end of the back "L" and the tape is in the center of the stiffener.

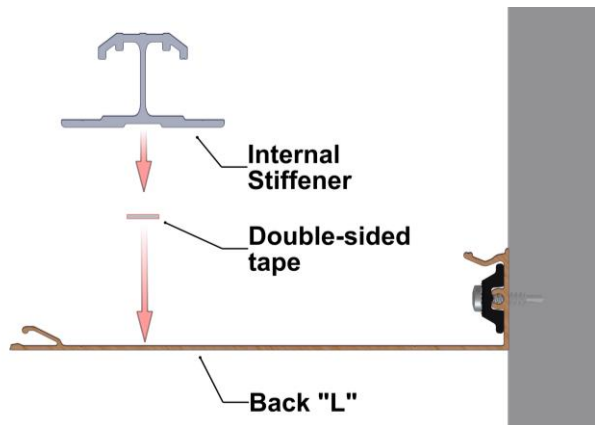

**Step 4**

-Fastening Stiffener in Fin orientation

Mechanically fasten the Stiffener to the back "L" using 1/8" Dome Head Rivets (Aluminum). Drill the flange of the Stiffener using a 1/8" Drill bit and fasten two Rivets at the top or one end to mitigate movement of the stiffener over time.

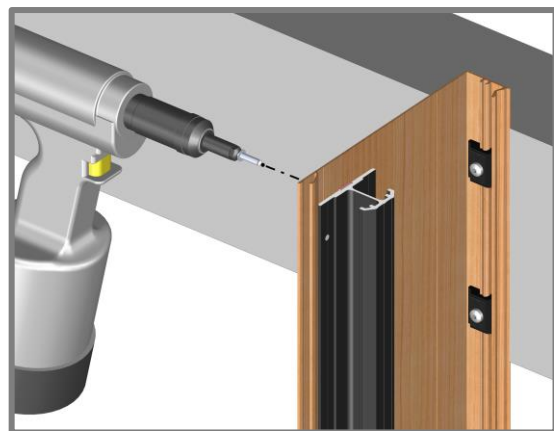

Step 4.1

-Fastening Stiffener Batten orientation  
Mechanically fasten the Stiffener to the back "L" using the Mounting Clips and #12 Fasteners. Refer to Step 1, Page 13 for mounting.

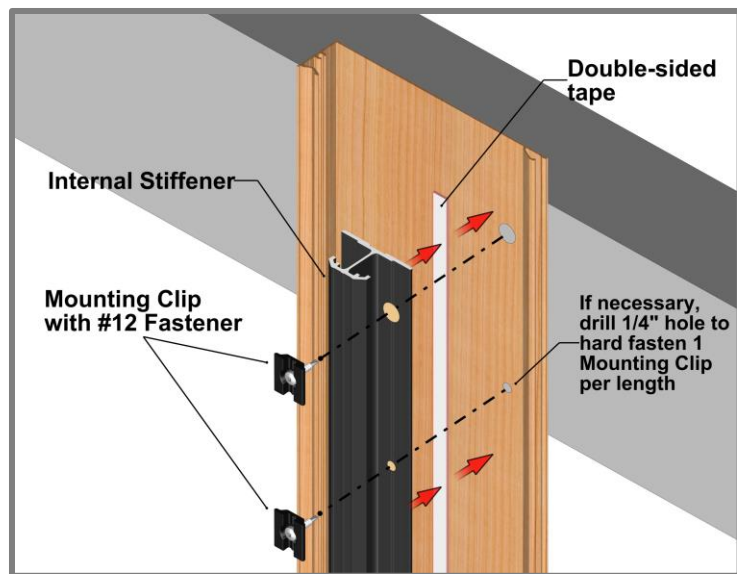

Step 5

Refer to Page 13-14 for Front "L" and End Cap install and details.



# Appendix

## Expansion and Contraction Tables

TABLE 1 - IMPERIAL

		AVERAGE TEMPERATURE AT TIME OF CUTTING & INSTALLATION											
°C		-50	-40	-30	-20	-10	0	10	20	30	40	50	
°F		-58	-40	-22	-4	14	32	50	68	86	104	122	
MIN/MAX POST CONSTRUCTION TEMP.	°C	°F	EXPANSION OR CONTRACTION (INCH/FOOT)										
	-50	-58	0.000	-0.003	-0.005	-0.008	-0.011	-0.014	-0.016	-0.019	-0.022	-0.024	-0.027
	-40	-40	0.003	0.000	-0.003	-0.005	-0.008	-0.011	-0.014	-0.016	-0.019	-0.022	-0.024
	-30	-22	0.005	0.003	0.000	-0.003	-0.005	-0.008	-0.011	-0.014	-0.016	-0.019	-0.022
	-20	-4	0.008	0.005	0.003	0.000	-0.003	-0.005	-0.008	-0.011	-0.014	-0.016	-0.019
	-10	14	0.011	0.008	0.005	0.003	0.000	-0.003	-0.005	-0.008	-0.011	-0.014	-0.016
	0	32	0.014	0.011	0.008	0.005	0.003	0.000	-0.003	-0.005	-0.008	-0.011	-0.014
	10	50	0.016	0.014	0.011	0.008	0.005	0.003	0.000	-0.003	-0.005	-0.008	-0.011
	20	68	0.019	0.016	0.014	0.011	0.008	0.005	0.003	0.000	-0.003	-0.005	-0.008
	30	86	0.022	0.019	0.016	0.014	0.011	0.008	0.005	0.003	0.000	-0.003	-0.005
	40	104	0.024	0.022	0.019	0.016	0.014	0.011	0.008	0.005	0.003	0.000	-0.003
	50	122	0.027	0.024	0.022	0.019	0.016	0.014	0.011	0.008	0.005	0.003	0.000

TABLE 2 - METRIC

		AVERAGE TEMPERATURE AT TIME OF CUTTING & INSTALLATION											
°C		-50	-40	-30	-20	-10	0	10	20	30	40	50	
°F		-58	-40	-22	-4	14	32	50	68	86	104	122	
MIN/MAX POST CONSTRUCTION TEMP.	°C	°F	EXPANSION OR CONTRACTION (MM/METER)										
	-50	-58	0.000	-0.230	-0.460	-0.690	-0.920	-1.150	-1.380	-1.610	-1.840	-2.070	-2.300
	-40	-40	0.230	0.000	-0.230	-0.460	-0.690	-0.920	-1.150	-1.380	-1.610	-1.840	-2.070
	-30	-22	0.460	0.230	0.000	-0.230	-0.460	-0.690	-0.920	-1.150	-1.380	-1.610	-1.840
	-20	-4	0.690	0.460	0.230	0.000	-0.230	-0.460	-0.690	-0.920	-1.150	-1.380	-1.610
	-10	14	0.920	0.690	0.460	0.230	0.000	-0.230	-0.460	-0.690	-0.920	-1.150	-1.380
	0	32	1.150	0.920	0.690	0.460	0.230	0.000	-0.230	-0.460	-0.690	-0.920	-1.150
	10	50	1.380	1.150	0.920	0.690	0.460	0.230	0.000	-0.230	-0.460	-0.690	-0.920
	20	68	1.610	1.380	1.150	0.920	0.690	0.460	0.230	0.000	-0.230	-0.460	-0.690
	30	86	1.840	1.610	1.380	1.150	0.920	0.690	0.460	0.230	0.000	-0.230	-0.460
	40	104	2.070	1.840	1.610	1.380	1.150	0.920	0.690	0.460	0.230	0.000	-0.230
	50	122	2.300	2.070	1.840	1.610	1.380	1.150	0.920	0.690	0.460	0.230	0.000

**TABLE 3**

		PSF (FACTORED/ULITIMATE)		
		10	20	30
ALLOWABLE SPAN (ft)	2", 4", 6" LINK & LOCK			
	6'			
	8'			
	12'			

All testing has been performed using L/180 deflection limits

**TABLE 4**

		PSF (FACTORED/ULITIMATE)		
		10	20	30
ALLOWABLE SPAN (ft)	8" LINK & LOCK			
	6'			
	8'			

All testing has been performed using L/180 deflection limits

## Sound Absorption (NRC & SAA)



LINEAR METAL CEILINGS:	SOUND ABSORPTION	
	NRC	SAA
6" LINK & LOCK BAFFLES @ 6" O.C. w. insulation <sup>1</sup>	0.80	0.81
6" LINK & LOCK BAFFLES @ 6" O.C	0.10	0.12

*The test reported in this document conformed explicitly with ASTM C423-17: "Standard Test Method for Sound Absorption and Sound Absorption Coefficients by the Reverberation Room Method."*

*<sup>1</sup>Insulation = 1" Fiberglass backer, 3lbs/ft<sup>3</sup> density*

## Proper Handling of Longboard Products



To help avoid injury and product damage, Longboard products require proper handling to and from storage areas during installation. When carrying or installing any products it is recommended that they be moved or carried by at least two people with each support point approximately 4ft from the ends. **Carrying products without proper support can cause excessive bending which may damage the appearance or finish of the product.** Any short cut lengths should also be carried on edge while supporting the material. See below for details.

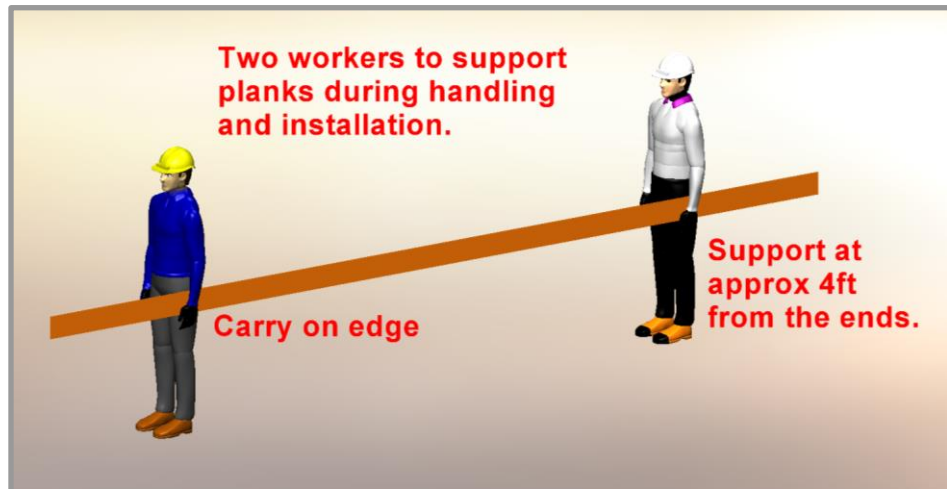
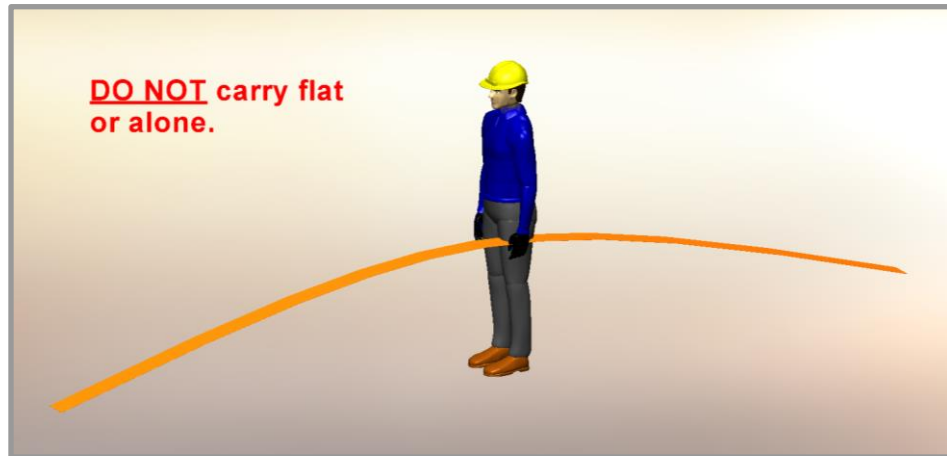

### ⚠️ Delivery, Storage & Handling ⚠️

- Always inspect the delivery for damage and contact LB ASAP if there are any issues: [info@longboardproducts.com](mailto:info@longboardproducts.com) or 1-800-604-0343 and include your PO# and any pictures if possible. Longboard is not responsible for the installation of blemished or damaged material.
- Be sure to store the material flat, keep it dry, safe & secure and remain in unopened cartons until ready to be installed.
- Always wear appropriate PPE when handling products.





Longboard Architectural Products Inc.  
© Longboard Architectural Products Inc. All rights reserved.

Longboard® is a registered trademark of Longboard Architectural Products Inc.

Longboard  
1777 Clearbrook Road  
Abbotsford, BC V2T 8X8  
Canada  
[longboardproducts.com](http://longboardproducts.com)

Every effort has been made to ensure that the information in these installation guidelines is accurate. Longboard is not responsible for printing or clerical errors.

For more information, contact client care at [info@longboardproducts.com](mailto:info@longboardproducts.com) or call toll free 1-800-604-0343.

## Tongue & Groove Systems

### V-Groove Planks

Size	* 48 sq. ft. box quantities		‡ 96 sq. ft. box quantities	
	12' *	24' *	12' Perf *	24' Perf *
2½"	3V.145	-	3VP.145	-
4"	4V.145	4V.289	-	-
6"	6V.145	6V.289	6VP.145	6VP.289

### Smooth Planks

Size	12' *	24' *	12' Perf *	24' Perf *
6"	6PSP.145	6PSP.289	6PSPP.145	6PSPP.289

### Channel Planks

Size	12' *	24' *	12' Perf *	24' Perf *
6"	6CH.145	6CH.289	-	-

### Bevel Planks

Size	12' *	24' *	12' Perf *	24' Perf *
6" Single	6SB.145	6SB.289	-	-
6" Triple	6TB.145	6TB.289	-	-

### Castellation Planks

Size	12' *	24' *	12' Perf *	24' Perf *
4"	4CA.145	4CA.289	-	-
8"	8CA.145	8CA.289	-	-

## Trim Components

Type	Style	Product	Dimensions	SKU
Starter	Precision	Starter J-Track	(5/8") - 12'	1SJT.145
Starter	Traditional	Starter Strip	(1-7/8") - 12'	2SS.145
Starter	Traditional	Back-to-Back Starter Strip	(1-1/4")	2BTBSS.145
J-Track	Precision	Two Piece J-Track	(5/8") - 12'	1X1JT.145
J-Track	Precision	J-Track	(5/8") - 12'	1JT.145
J-Track	Craftsman	J-Track	(7/8") - 12'	1JT23.145
J-Track	Craftsman	Two Piece J-Track	(7/8") - 12'	JT23S.145
J-Track	Traditional	Two Piece J-Track	(1-3/8") - 12'	1X2JT.145
Corner	Precision	Outside Corner	(3/16") - 12'	05OC.145
Corner	Craftsman	Inside Corner	(3/4") - 12'	1IC.145
Corner	Craftsman	Outside Corner	(1") - 12'	1OC.145
Corner	Traditional	Corner Set	(2") - 12'	2CORS.145
Corner	Traditional	3" Smooth	(3") - 24'	3SCP.289
Corner	Traditional	3" V-Groove	(3") - 24'	3SVP.289
Reveal	Precision	Flat Reveal	(1/2") - 12'	1FR.145
Reveal	Precision	T&G Flat Reveal	(1/2") - 24'	1TGRF.289
Reveal	Craftsman	U-Reveal Set	(3/4") - 12'	1URS.145
Reveal	Craftsman	T&G U-Reveal	(3/4) - 24'	1TGURK.289
Reveal	Traditional	U-Reveal Set	(1-1/2") - 12'	2URS.145
Reveal	Traditional	Flat Reveal Set	(1-1/2") - 12'	2FRS.145
Reveal	Traditional	T&G U-Reveal	(1 1/2") - 24'	2TGURK.289
Reveal	Traditional	Offset Flat Reveal Set, J-Track Base	(2") - 12'	2OFFJ.145
Reveal	Traditional	Offset Flat Reveal Set, Termination Base	(2") - 12'	2OFFT.145
Termination	Precision	Termination Set	(5/8") - 12'	1TS.145
Termination	Craftsman	Termination Set	(7/8") - 12'	TS23S.145
Termination	Traditional	Termination Set	(1-3/8") - 12'	2TS.145
Compression Joints	Traditional	Compression Joint	(1-3/8") - 24'	2CJ.289

## Accessories

Product	Qty	SKU
Quick Screen Clips	1750, box	CLIP.N1750
Quick Screen Clips	100, bag	CLIP.N100
Touch Up Pens	N/A	TUP

*Reach out to confirm color with account manager.*

## Acoustical Soundtex® Scrim

Size	12' *	24' *
6" V-Groove Plank	6PSP.145	6PSP.289
6" Smooth Plank	6PSPPA.145	6PSPPA.289

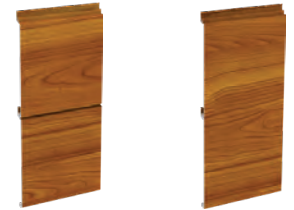

V-Groove Planks

Smooth Planks



Bevel Planks



Castellation Planks



Perforated Planks



Channel Planks



Precision Starter J-Track



Traditional Starter Strip



Traditional Back-to-Back Starter Strip



Precision Two-Piece J-Track



Precision J-Track



Craftsman J-Track



Craftsman Two Piece J-Track



Traditional Two Piece J-Track



Precision Outside Corner



Craftsman Inside Corner



Craftsman Outside Corner



Traditional Corner Set



3" Smooth Corner



3" V Groove Corner



Precision Flat Reveal



Precision T&amp;G Flat Reveal



Craftsman U-Reveal Set



Craftsman T&amp;G U-Reveal



Traditional U-Reveal Set



Traditional Flat Reveal Set



Traditional T&amp;G U-Reveal



Traditional Offset Flat Reveal Set, J-Track Base



Traditional Offset Flat Reveal Set, Termination Base



Precision Termination Set



Craftsman Termination Set



Traditional Termination Set



Traditional Compression Joint

## Link & Lock™ Battens

Size	12'	24'	End Caps (20/box)	End Mounts (20/box)
2"	2X2LL.145	2X2LL.289	2LLEC.2	2LLEM.2
4"	2X4LL.145	2X4LL.289	2LLEC.4	2LLEM.4
6"	2X6LL.145	2X6LL.289	2LLEC.6	2LLEM.6
8"	2X8LL.145	2X8LL.289	2LLEC.8	2LLEM.8

### Link & Lock™ HD Battens

6"	2X6LLHD.145	2X6LLHD.289	2LLHDEC.6	2LLHDEM.6
8"	2X8LLHD.145	2X8LLHD.289	2LLHDEC.8	2LLHDEM.8

### Link & Lock™ Box Battens

4 x 4"	4X4LL.145	4X4LL.289	4LLEC.4	-
4 x 6"	4X6LL.145	4X6LL.289	4LLEC.6	-



Link & Lock™ Box Battens

Mounting Accessories	Qty	SKU
Link & Lock Mounting Clip	48, bag	LLMC.N48
Dewalt® 1/2" Pilot Point Drill Bit	1	DRILLBT.05
24' Link & Lock Internal Stiffener	1	LLSTIFF.289
3M® Double Sided Adhesive Tape - 108'	1, roll	LLTAPE.1296

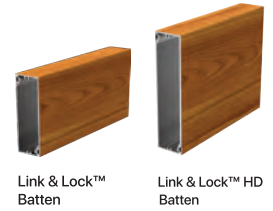

Link & Lock™ Batten

Link & Lock™ HD Batten

### Link & Lock™ Mounting Brackets

Product	Single	Dual
45° LEFT FIXED	LLMBK.45LF	LLMDK.45LF
45° RIGHT FIXED	LLMBK.45RF	LLMDK.45RF
90° CENTER FIXED	LLMBK.90F	LLMDK.90F
45° LEFT SLIDING	LLMBK.45LS	LLMDK.45LS
45° RIGHT SLIDING	LLMBK.45RS	LLMDK.45RS
90° CENTER SLIDING	LLMBK.90S	LLMDK.90S



Single

Dual

Link & Lock™ Mounting Brackets

## Privacy Beam System

Size	Product	24'	End Caps (20/box)
1x3"	Privacy Beam	1X3B.289	1BEC.3
1x5"	Privacy Beam	1X5B.289	1BEC.5
2x2"	Single Post	2X2SP.289	2X2PC.2
2x3"	Double Post	2X3DP.289	2X3PC.3

Mounting Accessories	Qty	SKU
Spacer Block	100, box	2X2SB.N100
1" Spacer Bar Stock Length	1	1X2FB.145
1x3" Spacer Bar	100, box	1X2FB.1
1x5" Spacer Bar	100, box	1X2FB.3
3" Mounting Bracket	100, box	3PSMB.1
#10 Black Screws	100, box	PECS.N100



Privacy Beam

## Dauntless System

Dimensions	Product	12'	24'	End Caps (20/box)
1-5/8" x 4"	Beam	2X4CB.145	2X4CB.289	2BEC.4
1-5/8" x 6"	Beam	2X6B.145	2X6CB.289	2BEC.6

### Hanger Bracket Mounting System

Product	Kind	Qty	SKU
Side Rail	24' Carrier Rail	1	2CBSR.289
Beam Spline Connection Top	Accessory	1	BSCT.6
2" Hanger Bracket	Bracket	1	CBHB.2
4" Hanger Bracket	Bracket	1	CBHB.4
6" Hanger Bracket	Bracket	1	CBHB.6
8" Hanger Bracket	Bracket	1	CBHB.8
10" Hanger Bracket	Bracket	1	CBHB.10
12" Hanger Bracket	Bracket	1	CBHB.12

### Clip Mounting System

Product	Kind	Qty	SKU
Single Rail <sup>A</sup>	24' Carrier Rail	1	CBR.289
Double Rail <sup>A</sup>	24' Carrier Rail	1	CBDR.289
1-1/2" Single Hanger Clip	Clip	20, box	HCS.2
3" Hanger Clip	Clip	20, box	HC.3
Eye Bolt with T-Nuts	Attachment	20, box	CBEB.N20

<sup>A</sup>Includes 7 Eye-Bolts with T-Nuts



Clip Assembly



Hanger Bracket Assembly

# Finishes

## Woodgrains

Woodgrain	15 Year Finsh Warranty	20 Year Finish Warranty
<b>Beechwood</b>	15BEE	-
<b>Black Oak</b>	15BKO	-
<b>Birchwood</b>	15BWD	-
<b>Blonde Oak</b>	15BOK	-
<b>Burnt Cherry</b>	15BCY	-
<b>Dark Acacia</b>	15DAC	20DAC
<b>Dark Antique Oak</b>	15DAO	-
<b>Dark Bamboo</b>	15DBB	20DBB
<b>Dark Cherry</b>	15DCY	20DCY
<b>Dark Fir</b>	15DFR	20DFR
<b>Dark Knotty Pine</b>	15DKP	20DKP
<b>Dark National Walnut</b>	15DNW	20DNW
<b>Dark Olive</b>	15DOL	-
<b>Dark Walnut</b>	15DWL	-
<b>Driftwood</b>	15DWO	-
<b>Eirey Douglas</b>	15GDF	-
<b>Grey Hemlock</b>	15GHL	-
<b>Italian Rosewood</b>	15IRW	20IRW
<b>Light Bamboo</b>	15LBB	20LBB
<b>Light Cherry</b>	15LCY	-
<b>Light Fir</b>	15LFR	20LFR
<b>Light National Walnut</b>	15LNW	-
<b>Light Oak</b>	15LOK	-
<b>Light Olive</b>	15LOL	-
<b>National Mahogany</b>	15NMH	20NMH
<b>Southern Yellow Pine</b>	15SYP	-
<b>Table Walnut</b>	15TWL	20LFR
<b>Western Cedar</b>	15WCD	-
<b>White Oak</b>	15WOK	-

## Solid & Specialty

Solid & Specialty	15 Year Finsh Warranty	20 Year Finish Warranty
<b>Anodic Ice</b>	15AIC	20AIC
<b>Biscotti</b>	15BIS	20BIS
<b>Black</b>	15BLA	20BLA
<b>Bone White</b>	15BWH	20BWH
<b>Brick Red</b>	15BRD	20BRD
<b>Burnt Sienna</b>	15BSN	20BSN
<b>Canyon Vista</b>	15CVI	20CVI
<b>Ceramic Clay</b>	15CCL	20CCL
<b>Charcoal</b>	15CHA	20CHA
<b>Chili Pepper</b>	15CHP	20CHP
<b>Classic Bronze</b>	15CBZ	20CBZ
<b>Copper Penny</b>	15CPE	20CPE
<b>Dark Brown</b>	15DBR	20DBR
<b>Graphite</b>	15GRA	20GRA
<b>Medium Blue</b>	15MBL	20MBL
<b>Moonstone</b>	15MOO	20MOO
<b>Old Navy</b>	15ONA	20ONA
<b>Onyx Black</b>	15OBL	20OBL
<b>Platinum Ice</b>	15PIC	20PIC
<b>Slate Grey</b>	15SGR	20SGR
<b>Ultra White</b>	15UWH	20UWH
<b>Venus</b>	15VEN	20VEN

## Naturally Aged Metals

Naturally Aged Metals	15 Year Finsh Warranty	20 Year Finish Warranty
<b>Carbon Mist</b>	15CMI	-
<b>Molten</b>	15MOL	-
<b>Smokey Topaz</b>	15STO	-
<b>Toasted Mocha</b>	15TMO	-

### Example of complete product SKU

6V.289.15DFR  
(Product.Length.Finish)

# Finish Options

## Achieve your vision.

Whether creating a space that offers the warmth and appearance of Woodgrains, or the modern industrialized look of Naturally Aged Metals, we have a finish option for you.

Require a custom finish or color? Our experienced color-matching team can make it a reality!

Contact us to confirm lead times for orders greater than 15k sq.ft in the Most Popular Finishes category.

## Woodgrains

Longboard's woodgrain finishes have a slight texture with matte sheen.



## Solid & Specialty



**15 Year Non-Prorated Powder Coating Finish - 50 Year Non-Prorated Extruded Aluminum Profiles [ Limited Warranty ]**

**Warranty granted to (building owner):**

Product codes: Product description:

Install contractor

Project name

Project address

Address 2

Install start date

Finish:

Date of completion

Longboard Architectural Products Inc. ("Longboard," "The Company") products as identified by the Product Codes listed will conform to the standards set out in Clause 1 and Clause 2 of this Warranty, subject to the terms and conditions set out in Clause 3 and 4 of this Warranty.

**Clause 1**

Extruded Aluminum Profile(s) with Powder Coat Finish Longboard expressly warrants that its product line is free from manufacturing defects in material or workmanship.

- 1.1 When product is applied according to Longboard instructions and properly maintained, such product is guaranteed against the following:
- 1.2 Buckling: The product itself will be free of any buckling that is not associated with the substrate and/or structure to which the Longboard system is attached. For the purpose of this warranty, buckling shall be defined as warping of the product(s) exceeding one sixteenth of an inch out of plane per linear foot.
- 1.3 Corrosion: When installed in normal atmospheric conditions according to Longboard instructions and properly maintained, such product is further guaranteed against rusting and corroding. Subject to the limitations set out in Clause 3 and 4.
- 1.4 What we will do: If, during the fifteen (15) year Limited Warranty Period on the powder coating finish, the Product is defective in material or workmanship, Longboard will, in its sole discretion, either repair or replace the defective portion of the Product.
- 1.5 What we will do: If, during the fifty (50) year Limited Warranty Period on the extruded aluminum profiles, the Product is defective in material or workmanship, Longboard will, in its sole discretion, either repair or replace the defective portion of the Product.
- 1.6 After the 15th year, this Limited Warranty on the powder coated finish will expire and shall no longer be applicable.
- 1.7 After the 50th year, this Limited Warranty on the aluminum extruded profile(s) will expire and shall no longer be applicable.
- 1.8 Longboard replacement of the defective Product or reimbursement of this Limited Warranty is the exclusive remedy for the Covered Person for any defect in materials or workmanship. The Company will pay for all reasonable costs including material and labor as it relates to the repair and / or replacement of the defective Product.

**Clause 2**

Product Finish - AAMA 2604 Performance Specification

- 2.1 During the first fifteen (15) years of this warranty:
- 2.2 Checking/Cracking: No visible checking or cracking of the product finish on the building.
- 2.3 Chalking Resistance: No chalking of the product finish on the building in excess of that represented by No.8 rating based on ASTM D4214.
- 2.4 Color Retention: No color change of the product finish on the building greater than 5 (five) CIE Lab ΔE units calculated in accordance with ASTM 2244 Section 6.3. Color change shall be measured on the exposed paint surface which has been cleaned of oil, grease, chalk, oxidized film or other contaminants, corresponding values shall be measured on the control panel.
- 2.5 Gloss Retention: Coated surface will exhibit gloss retention of a minimum of 30% of the original. Gloss retention shall

be measured on the exposed paint surface which has been cleaned of oil, grease, chalk, oxidized film or other contaminants, corresponding values shall be measured on the control panel.

- 2.6 Adhesion: Adhesion of product finish when initially applied to test panels and measured by reference to AAMA 2604-02 Clause 7.4.2 will show no removal of the film.

**Clause 3**

- 3.1 Warranty Terms and Conditions:
- 3.2 The "Warranty Period" for the warranties in Clause 1 shall mean the respective number of years or for as long as the Covered Person commencing on the date of substantial completion named above shall live and own the property on which the material was originally installed.
- 3.3 Registration of the product is required within ninety (90) days from substantial completion for the warranty to be in effect. This warranty is valid for the original owner and one other subsequent owner of the structure where the product(s) have been installed.
- 3.4 Normal atmospheric conditions exclude corrosive or aggressive atmospheres such as those contaminated with chemical fumes or other corrosive elements. The product finish is not meant for marine use on boats, ships or offshore platforms.
- 3.5 The product finish warranties as outlined in Clause 2 shall include coverage of the finish as it relates to the impact affects from hail and woodpecker birds.
- 3.6 Under no circumstance shall Longboard's liability under this limited warranty exceed 2.5 times the total corresponding Longboard material cost (excluding sales tax, labor and installation related costs) as noted on the original purchase invoice and paid by the Buyer for the specific project.

**Clause 4**

- 4.1 This warranty will not extend or cover:
- 4.2 Damages to the coated metal caused by handling, shipping, processing and/or installation; or
- 4.3 Damages to the coated metal caused by scratching or abrading after installation; or
- 4.4 Damages to the coated metal as a result of standing water in horizontal installations.
- 4.5 The warranty will not be applicable to damage or failure, which is caused by acts of God, falling objects, external forces, explosions, fire, riots, civil commotion's, acts of war, or other such similar or dissimilar occurrences beyond The Company's control.
- 4.6 Customer shall make available to The Company the dates of the installation of the coated metal, the maintenance records including details of washing and cleaning procedures in compliance with the cleaning requirements as stated in the Required Maintenance section of this warranty. Customers shall demonstrate that the failure of the coated metal was due to a breach of the warranty stated herein.
- 4.7 Claims must be made in writing to Longboard within 30 days of the discovery of a problem and authorization obtained prior to beginning any repair and/or refinishing work.

The claimant must provide proof of coverage. Claims can be made by writing to Longboard at the Product Performance Department. After receiving such notice, The Company must be given a reasonable opportunity to inspect and verify the claim.

- 4.8 Longboard exclusive liability under this warranty, or otherwise, will be limited to refinishing and/or repairing, at The Company's sole discretion, the defective powder coated product. The warranty on any refinished, repaired or replaced coated metal supplied hereunder shall be for the remainder of the warranty period applicable to the originally coated metal. All warranty work will be performed by a company or contractor selected by Longboard. Color variance between refinished and/or repainted product and original shall not be indicative of a defect.
- 4.9 This warranty represents the entire agreement between parties in relation to its subject matter and supersedes any previous agreement whether written or oral between the parties in relation to its subject matter. The limited warranties state the entire liability of Longboard with respect to the products covered by them. The Company shall have no liability for any incidental or consequential damages. No company is authorized to make any representation or warranty on behalf of Longboard except as expressly set forth above, and any such statement shall not be binding on The Company. Except as expressly set forth above, Longboard makes no warranty of any kind, express or implied, including, without limitation, any implied warranty of merchantability or fitness for a particular purpose. Warranties shall be the duration of the limited warranty, or such shorter duration as provided under applicable local law. These limited warranties give you specific legal rights, and you may also have other rights which vary from area to area.
- 4.10 Nothing in this warranty shall be construed as a warranty of the workmanship of any installer or as imposing on Longboard any liability for unsatisfactory performance caused by faulty workmanship in installation.
- 4.11 It's agreed all parties involved that all claims and disputes relating to this agreement that cannot be settled through negotiation will try in good faith to first settle the dispute by mediation administered by the American Arbitration Association (Construction Industry Mediation Procedures) as a prelude to mandatory binding arbitration. Such binding arbitration is to be conducted and administered by the Construction Industry Arbitration Rules of the American Arbitration Association. Both seller and purchaser agree to share equally in the costs of both mediation and arbitration and that such binding arbitration will be the sole and final remedial action.
- 4.12 Required Maintenance. Depending on the Project Environment, follow the maintenance schedule as outlined in the Longboard Care & Maintenance Guide. Use a soft sponge or cloth, water and mild detergent, non-abrasive soap with the pH range of 5-9 to clean the powder coated area of dirt, grime and other debris. Pressure washing and the use of harsh detergents or chemicals is not recommended. Include in your maintenance records the following: date, time, specific products used, name of maintenance person and their designation, maintenance company name and general condition of the powder coated finish.

**I have read and agree to the terms of the Longboard® Product 15 year powder coated surface and 50 year aluminum extruded profile(s) warranty and acknowledge receipt of a copy of the Warranty Certificate.**

Name of owner or contractor:

Date:

Signature:



Duly authorized on behalf of Longboard:

Name and designation:

Date:

Signature:

## 20 Year Non-Prorated Powder Coating Finish - 50 Year Non-Prorated Extruded Aluminum Profiles [ Limited Warranty ]

**Warranty granted to (building owner):**

Product codes: Product description:

Install contractor

Project name

Project address

Address 2

Install start date

Finish:

Date of completion

Longboard Architectural Products Inc. ("Longboard," "The Company") products as identified by the Product Codes listed will conform to the standards set out in Clause 1 and Clause 2 of this Warranty, subject to the terms and conditions set out in Clause 3 and 4 of this Warranty.

**Clause 1**

Extruded Aluminum Profile(s) with Powder Coat Finish  
Longboard expressly warrants that its product line is free from manufacturing defects in material or workmanship.

- 1.1. When product is applied according to Longboard instructions and properly maintained, such product is guaranteed against the following:
- 1.2. Buckling: The product itself will be free of any buckling that is not associated with the substrate and/or structure to which the Longboard system is attached. For the purpose of this warranty, buckling shall be defined as warping of the product(s) exceeding one sixteenth of an inch out of plane per linear foot.
- 1.3. Corrosion: When installed in normal atmospheric conditions according to Longboard instructions and properly maintained, such product is further guaranteed against rusting and corroding. Subject to the limitations set out in Clause 3 and 4.
- 1.4. What we will do: If, during the twenty (20) year Limited Warranty Period on the powder coating finish, the Product is defective in material or workmanship, Longboard will, in its sole discretion, either repair or replace the defective portion of the Product.
- 1.5. What we will do: If, during the fifty (50) year Limited Warranty Period on the extruded aluminum profiles, the Product is defective in material or workmanship, Longboard will, in its sole discretion, either repair or replace the defective portion of the Product.
- 1.6. After the 20th year, this Limited Warranty on the powder coated finish will expire and shall no longer be applicable.
- 1.7. After the 50th year, this Limited Warranty on the aluminum extruded profile(s) will expire and shall no longer be applicable.
- 1.8. Longboard replacement of the defective Product or reimbursement of this Limited Warranty is the exclusive remedy for the Covered Person for any defect in materials or workmanship. The Company will pay for all reasonable costs including material and labor as it relates to the repair and / or replacement of the defective Product.

**Clause 2**

Product Finish - AAMA 2605 Performance Specification

- 2.1. During the first twenty (20) years of this warranty:
- 2.2. Checking/Cracking: No visible checking or cracking of the product finish on the building.
- 2.3. Chalking Resistance: No chalking of the product finish on the building in excess of that represented by No.8 rating based on ASTM D4214.
- 2.4. Color Retention: No color change of the product finish on the building greater than 5 (five) CIE Lab ΔE units calculated in accordance with ASTM 2244 Section 6.3. Color change shall be measured on the exposed paint surface which has been cleaned of oil, grease, chalk, oxidized film or other contaminants, corresponding values shall be measured on the control panel.
- 2.5. Gloss Retention: Coated surface will exhibit gloss retention of a minimum of 50% of the original. Gloss retention shall

be measured on the exposed paint surface which has been cleaned of oil, grease, chalk, oxidized film or other contaminants, corresponding values shall be measured on the control panel.

- 2.6. Adhesion: Adhesion of product finish when initially applied to test panels and measured by reference to AAMA 2605-02 Clause 7.4.2 will show no removal of the film.

**Clause 3**

- 3.1. Warranty Terms and Conditions:
- 3.2. The "Warranty Period" for the warranties in Clause 1 shall mean the respective number of years or for as long as the Covered Person commencing on the date of substantial completion named above shall live and own the property on which the material was originally installed.
- 3.3. Registration of the product is required within ninety (90) days from substantial completion for the warranty to be in effect. This warranty is valid for the original owner and one other subsequent owner of the structure where the product(s) have been installed.
- 3.4. Normal atmospheric conditions exclude corrosive or aggressive atmospheres such as those contaminated with chemical fumes or other corrosive elements. The product finish is not meant for marine use on boats, ships or offshore platforms.
- 3.5. The product finish warranties as outlined in Clause 2 shall include coverage of the finish as it relates to the impact affects from hail and woodpecker birds.
- 3.6. Under no circumstance shall Longboard's liability under this limited warranty exceed 2.5 times the total corresponding Longboard material cost (excluding sales tax, labor and installation related costs) as noted on the original purchase invoice and paid by the Buyer for the specific project.

**Clause 4**

- 4.1. This warranty will not extend or cover:
- 4.2. Damages to the coated metal caused by handling, shipping, processing and/or installation; or
- 4.3. Damages to the coated metal caused by scratching or abrading after installation; or
- 4.4. Damages to the coated metal as a result of standing water in horizontal installations.
- 4.5. The warranty will not be applicable to damage or failure, which is caused by acts of God, falling objects, external forces, explosions, fire, riots, civil commotion's, acts of war, or other such similar or dissimilar occurrences beyond The Company's control.
- 4.6. Customer shall make available to The Company the dates of the installation of the coated metal, the maintenance records including details of washing and cleaning procedures in compliance with the cleaning requirements as stated in the Required Maintenance section of this warranty. Customers shall demonstrate that the failure of the coated metal was due to a breach of the warranty stated herein.
- 4.7. Claims must be made in writing to Longboard within 30 days of the discovery of a problem and authorization obtained prior to beginning any repair and/or refinishing work.

The claimant must provide proof of coverage. Claims can be made by writing to Longboard at the Product Performance Department. After receiving such notice, The Company must be given a reasonable opportunity to inspect and verify the claim.

- 4.8. Longboard exclusive liability under this warranty, or otherwise, will be limited to refinishing and/or repairing, at The Company's sole discretion, the defective powder coated product. The warranty on any refinished, repaired or replaced coated metal supplied hereunder shall be for the remainder of the warranty period applicable to the originally coated metal. All warranty work will be performed by a company or contractor selected by Longboard. Color variance between refinished and/or repainted product and original shall not be indicative of a defect.
- 4.9. This warranty represents the entire agreement between parties in relation to its subject matter and supersedes any previous agreement whether written or oral between the parties in relation to its subject matter. The limited warranties state the entire liability of Longboard with respect to the products covered by them. The Company shall have no liability for any incidental or consequential damages. No person is authorized to make any representation or warranty on behalf of Longboard except as expressly set forth above, and any such statement shall not be binding on The Company. Except as expressly set forth above, Longboard makes no warranty of any kind, express or implied, including, without limitation, any implied warranty of merchantability or fitness for a particular purpose. Warranties shall be the duration of the limited warranty, or such shorter duration as provided under applicable local law. These limited warranties give you specific legal rights, and you may also have other rights which vary from area to area.
- 4.10. Nothing in this warranty shall be construed as a warranty of the workmanship of any installer or as imposing on Longboard any liability for unsatisfactory performance caused by faulty workmanship in installation.
- 4.11. It's agreed all parties involved that all claims and disputes relating to this agreement that cannot be settled through negotiation will try in good faith to first settle the dispute by mediation administered by the American Arbitration Association (Construction Industry Mediation Procedures) as a prelude to mandatory binding arbitration. Such binding arbitration is to be conducted and administered by the Construction Industry Arbitration Rules of the American Arbitration Association. Both seller and purchaser agree to share equally in the costs of both mediation and arbitration and that such binding arbitration will be the sole and final remedial action.
- 4.12. Required Maintenance. Depending on the Project Environment, follow the maintenance schedule as outlined in the Longboard Care & Maintenance Guide. Use a soft sponge or cloth, water and mild detergent, non-abrasive soap with the pH range of 5-9 to clean the powder coated area of dirt, grime and other debris. Pressure washing and the use of harsh detergents or chemicals is not recommended. Include in your maintenance records the following: date, time, specific products used, name of maintenance person and their designation, maintenance company name and general condition of the powder coated finish.

**I have read and agree to the terms of the Longboard® Product 15 year powder coated surface and 50 year aluminum extruded profile(s) warranty and acknowledge receipt of a copy of the Warranty Certificate.**

Name of owner or contractor:

Date:

Signature:



Duly authorized on behalf of Longboard:

Name and designation:

Date:

Signature: