

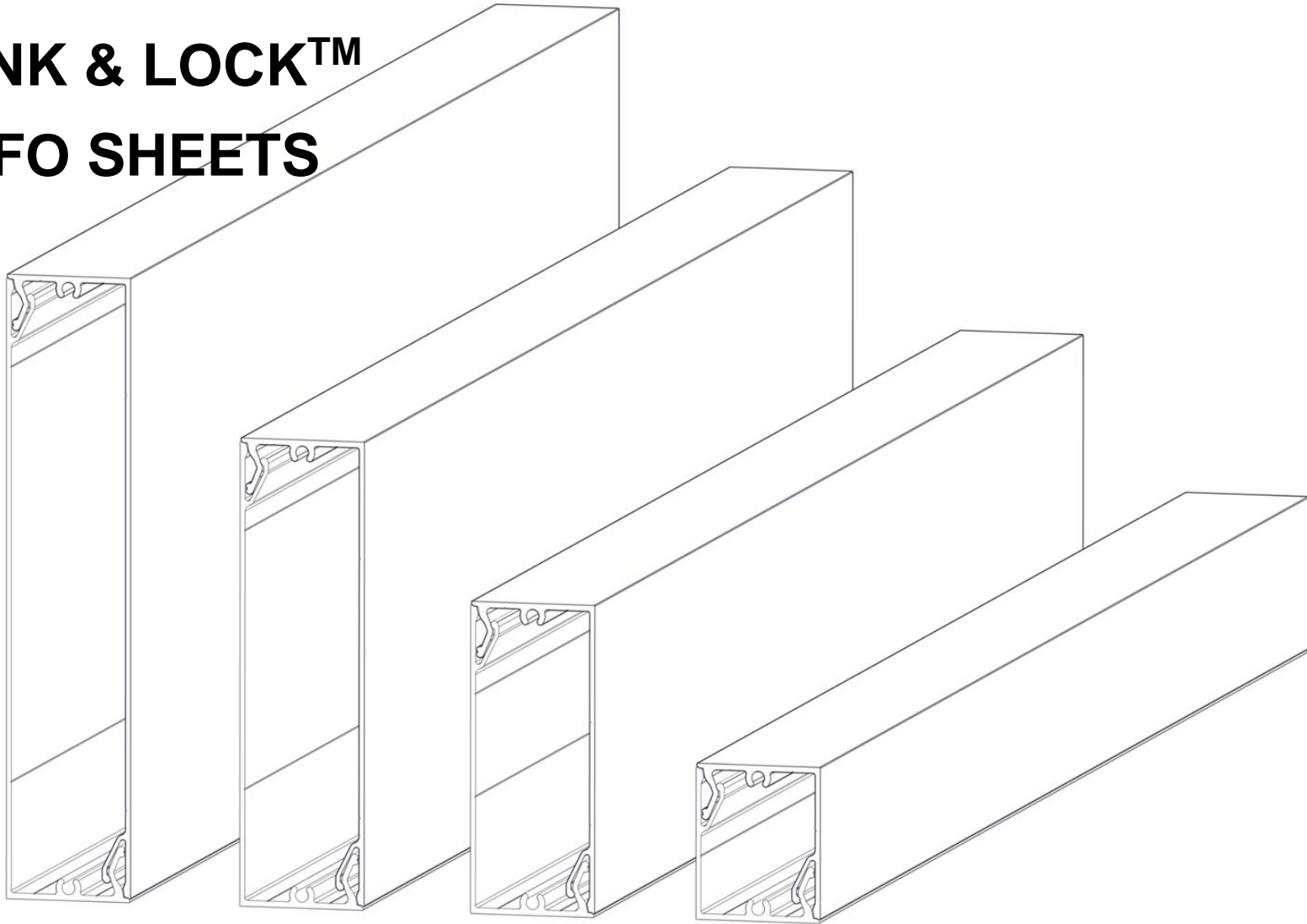

LONGBOARD®
INSPIRING ARCHITECTURE

LINK & LOCK™

INFO SHEETS



L&L Dimensions

Finishes:

Woodgrains, Solid, Specialty

Custom Solid Color Matching - (Additional lead times apply)



2" Link & Lock



4" Link & Lock



6" Link & Lock



8" Link & Lock

Actual Sizes & Weights

L&L	Width	Depth	Length	Weight(lbs/LF) *per set
2"	2" (50.8mm)	1 5/8" (41.3mm)	12'/24'	0.93
4"	4" (101.6mm)	1 5/8" (41.3mm)	12'/24'	1.3
6"	6" (152.4mm)	1 5/8" (41.3mm)	12'/24'	1.6
8"	8" (203mm)	1 5/8" (41.3mm)	12'/24'	1.9
4"x4"	4" (101.6mm)	4" (101.6mm)	12'/24'	1.8
4"x6"	4" (101.6mm)	6" (152.4mm)	12'/24'	2.1

Physical data:

- 6063-T5 Extruded Aluminum
- 100% recyclable
- Warranty on Finish: 15 year (standard)/20 year* (ultra) (*10week lead time); Aluminum: 50 year

Link & Lock™ Battens

Size	12'	24'	End Caps (20/box)	End Mounts (20/box)
2"	2X2LL.145	2X2LL.289	2LLEC.2	2LLEM.2
4"	2X4LL.145	2X4LL.289	2LLEC.4	2LLEM.4
6"	2X6LL.145	2X6LL.289	2LLEC.6	2LLEM.6
8"	2X8LL.145	2X8LL.289	2LLEC.8	2LLEM.8

Link & Lock™ Box Battens

4 x 4"	4X4LL.145	4X4LL.289	4LLEC.4	-
4 x 6"	4X6LL.145	4X6LL.289	4LLEC.6	-

Mounting Accessories	Qty	SKU
Link & Lock Mounting Clip	48, bag	LLMC.N48
Link & Lock™ Isolation Washer	48, bag	FAST.5003.BOX48
Dewalt® 1/2" Pilot Point Drill Bit	1	DRILLBT.05
24' Link & Lock Internal Stiffener	1	LLSTIFF.289
3M® Double Sided Adhesive Tape - 108'	1, roll	LLTAPE.1296



4"x4" Link & Lock



4"x6" Link & Lock

L&L Installation Components [See L&L Install Guide for details](#)

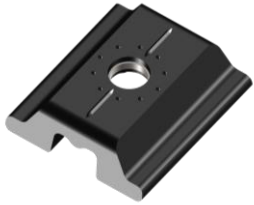

Mounting Clip:

- Nylon with embedded SS washer
- Used on Batten and Fin orientation to secure the back "L" to the substrate
- Included in order with L&L for 6' O.C. attachment
- Additional Clips purchased separately (48 pcs/box)



End Mount:

- Extruded 6063-T5 Aluminum Alloy, powder coated black
- Used for End-to-End attachment to provide a solid mount for the L&L set to wrap around and snap together
- Available for 2", 4", 6" & 8" L&L
- Purchased separately (20 pcs/box)



#12 Fastener (By others):

- Zinc-plated or Stainless Steel
- Used for attaching the back "L" to the substrate
- Use the correct fastener for the required project substrate
- Supplied by others



Isolation Washer:

- PA6 Nylon
- Used to isolate the back "L" from the substrate
- Max. 4x to shim L&L (1/4" total)
- 1/16" thick, 1 1/2" O.D.
- Purchased separately in packages of 48



1/2" Pilot Point Drill Bit:

- 1/2" Pilot Point Drill Bit
- Used for Drilling out the holes for mounting the L&L to the substrate
- See Install Guide for drilling details



Paint Pen:

- Color choices available
- Used for touch ups at the ends before installing End Caps
- Purchased separately



Double-sided Adhesive Tape:

- 3M VHB Tape
- Used for attaching the Internal Stiffener to the back "L" of the L&L set
- Tape is placed in the center of the Stiffener



Internal Stiffener:

- Extruded 6063-T5 Aluminum Alloy (comes powder coated black)
- Used for reinforcing the 4", 6" & 8" L&L to allow for up to 12' spans between attachment points
- See Testing and Loading page for span allowance

L&L Install Images

See L&L Install Guide for details

BIM & CAD: RVT & DWG files available, see website for details

Mounting Clip (Fin orientation)

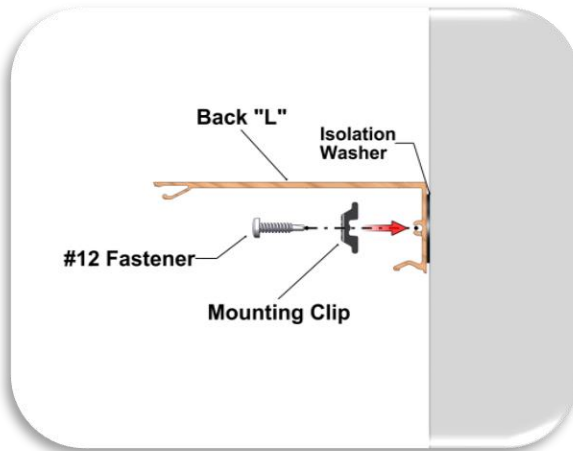

End Mount

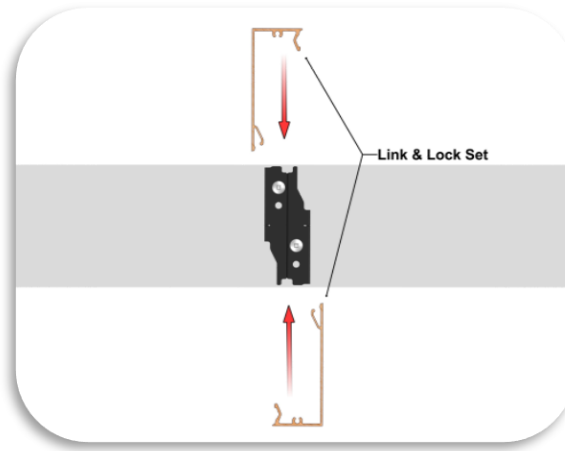

Internal Stiffener (with Double-sided Tape)

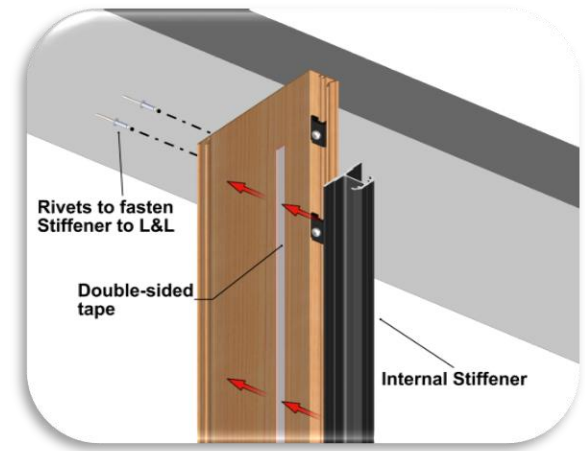

Mounting Clip (Batten orientation)

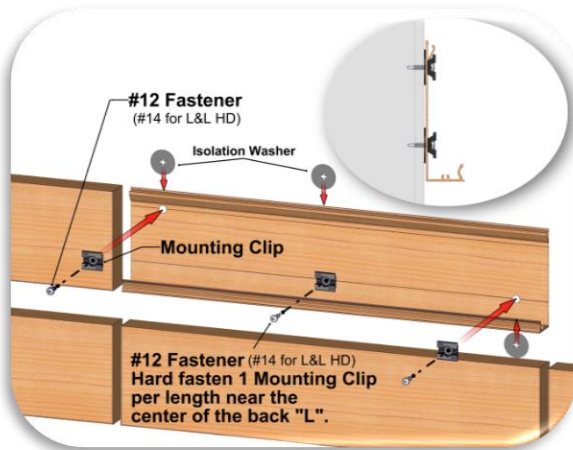

Paint Pen (for cut edges)

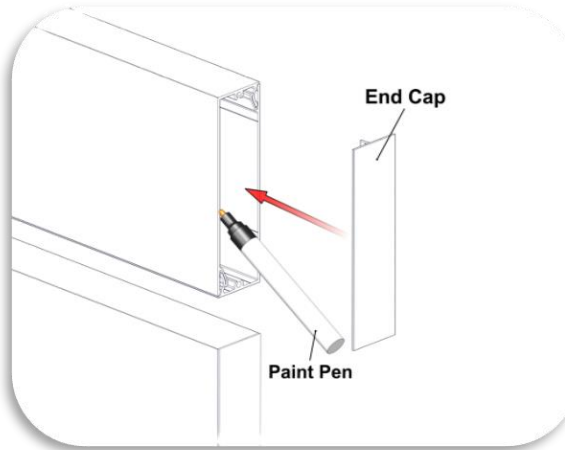

Drilling (Fin orientation)



L&L Testing Data and Allowable Spans

LONGBOARD®
INSPIRING ARCHITECTURE

2" LINK & LOCK		PSF (FACTORED/ULTIMATE)										
		30	40	50	60	70	80	90	100	110	120	
ALLOWABLE SPAN (ft)	4'	[Green]										
	6'	[Green]										
	8'	[Green]										
	10'	[Green]										

All testing has been performed using L/180 deflection limits

LONGBOARD®
INSPIRING ARCHITECTURE

4" LINK & LOCK		PSF (FACTORED/ULTIMATE)										
		30	40	50	60	70	80	90	100	110	120	
ALLOWABLE SPAN (ft)	2'	[Green]										
	4'	[Green]										
	6'	[Green]										
	8'	[Green]										

All testing has been performed using L/180 deflection limits

LONGBOARD®
INSPIRING ARCHITECTURE

6" LINK & LOCK		PSF (FACTORED/ULTIMATE)										
		30	40	50	60	70	80	90	100	110	120	
ALLOWABLE SPAN (ft)	2'	[Green]										
	4'	[Green]										
	6'	[Green]										

All testing has been performed using L/180 deflection limits

LONGBOARD®
INSPIRING ARCHITECTURE

8" LINK & LOCK		PSF (FACTORED/ULTIMATE)											
		30	40	50	60	70	80	90	100	110	120		
ALLOWABLE SPAN (ft)	2'	[Green]											
	4'	[Green]											
	6'	[Green]											

All testing has been performed using L/180 deflection limits

Testing:
ICC-ESR 4183 Evaluation Report - Division: 05 00 00 – METALS

- Section: 05 50 00 - Metal Fabrications

LARR - Los Angeles Department of Building Safety (LADBS) accepts ICC-ES reports as proof of compliance

Florida Product Code: FL41842

International Building Code (IBC). International Residential Code (IRC)
California Building Code (CBC), California Residential Code (CRC)
City of Los Angeles Building Code (LABC)
City of Los Angeles Residential Code (LARC)
Florida Building Code – Building, Florida Building Code - Residential

 Fire Rating: Class A Non-Combustible by ASTM E136 & ASTM E84

 Light Reflectance: 5% (Black) up to 73.2% (Ultra White)

LONGBOARD®
INSPIRING ARCHITECTURE

4x4 LINK & LOCK		PSF (FACTORED/ULTIMATE)										
		30	40	50	60	70	80	90	100	110	120	
ALLOWABLE SPAN (ft)	8'	[Green]										
	10'	[Green]										
	12'	[Green]										

All testing has been performed using L/180 deflection limits

LONGBOARD®
INSPIRING ARCHITECTURE

4x6 LINK & LOCK™		PSF (FACTORED/ULTIMATE)										
		30	40	50	60	70	80	90	100	110	120	
ALLOWABLE SPAN (ft)	8'	[Green]										
	10'	[Green]										
	12'	[Green]										

All testing has been performed using L/180 deflection limits

L&L Allowable Spans with Stiffener

LONGBOARD®
INSPIRING ARCHITECTURE

4" LINK & LOCK W. STIFFENER		PSF (FACTORED/ULTIMATE)												
		30	40	50	60	70	80	90	100	110	120			
ALLOWABLE SPAN (ft)	**4'	✓	✓	✓	✓	✓	✓	✓	✓	✓	✓	✓	✓	✓
	**6'	✓	✓	✓	✓	✓	✓	✓	✓	✓	✓	✓	✓	✓
	**8'	✓	✓	✓	✓	✓	✓	✓	✓	✓	✓	✓	✓	✓
	**10'	✓	✓	✓	✓	✓	✓	✓	✓	✓	✓	✓	✓	✓
	**12'	✓	✓	✓	✓	✓	✓	✓	✓	✓	✓	✓	✓	✓

All testing has been performed using L/180 deflection limits
**Using Longboard Link & Lock Internal Stiffener

LONGBOARD®
INSPIRING ARCHITECTURE

6" LINK & LOCK W. STIFFENER		PSF (FACTORED/ULTIMATE)												
		30	40	50	60	70	80	90	100	110	120			
ALLOWABLE SPAN (ft)	**4'	✓	✓	✓	✓	✓	✓	✓	✓	✓	✓	✓	✓	✓
	**6'	✓	✓	✓	✓	✓	✓	✓	✓	✓	✓	✓	✓	✓
	**8'	✓	✓	✓	✓	✓	✓	✓	✓	✓	✓	✓	✓	✓
	**10'	✓	✓	✓	✓	✓	✓	✓	✓	✓	✓	✓	✓	✓

All testing has been performed using L/180 deflection limits
**Using Longboard Link & Lock Internal Stiffener

LONGBOARD®
INSPIRING ARCHITECTURE

8" LINK & LOCK W. STIFFENER		PSF (FACTORED/ULTIMATE)												
		30	40	50	60	70	80	90	100	110	120			
ALLOWABLE SPAN (ft)	**2'	✓	✓	✓	✓	✓	✓	✓	✓	✓	✓	✓	✓	✓
	**4'	✓	✓	✓	✓	✓	✓	✓	✓	✓	✓	✓	✓	✓
	**6'	✓	✓	✓	✓	✓	✓	✓	✓	✓	✓	✓	✓	✓
	**8'	✓	✓	✓	✓	✓	✓	✓	✓	✓	✓	✓	✓	✓

All testing has been performed using L/180 deflection limits
**Using Longboard Link & Lock Internal Stiffener



LONGBOARD®
INSPIRING ARCHITECTURE

LINK & LOCK™ HD

INFO SHEETS

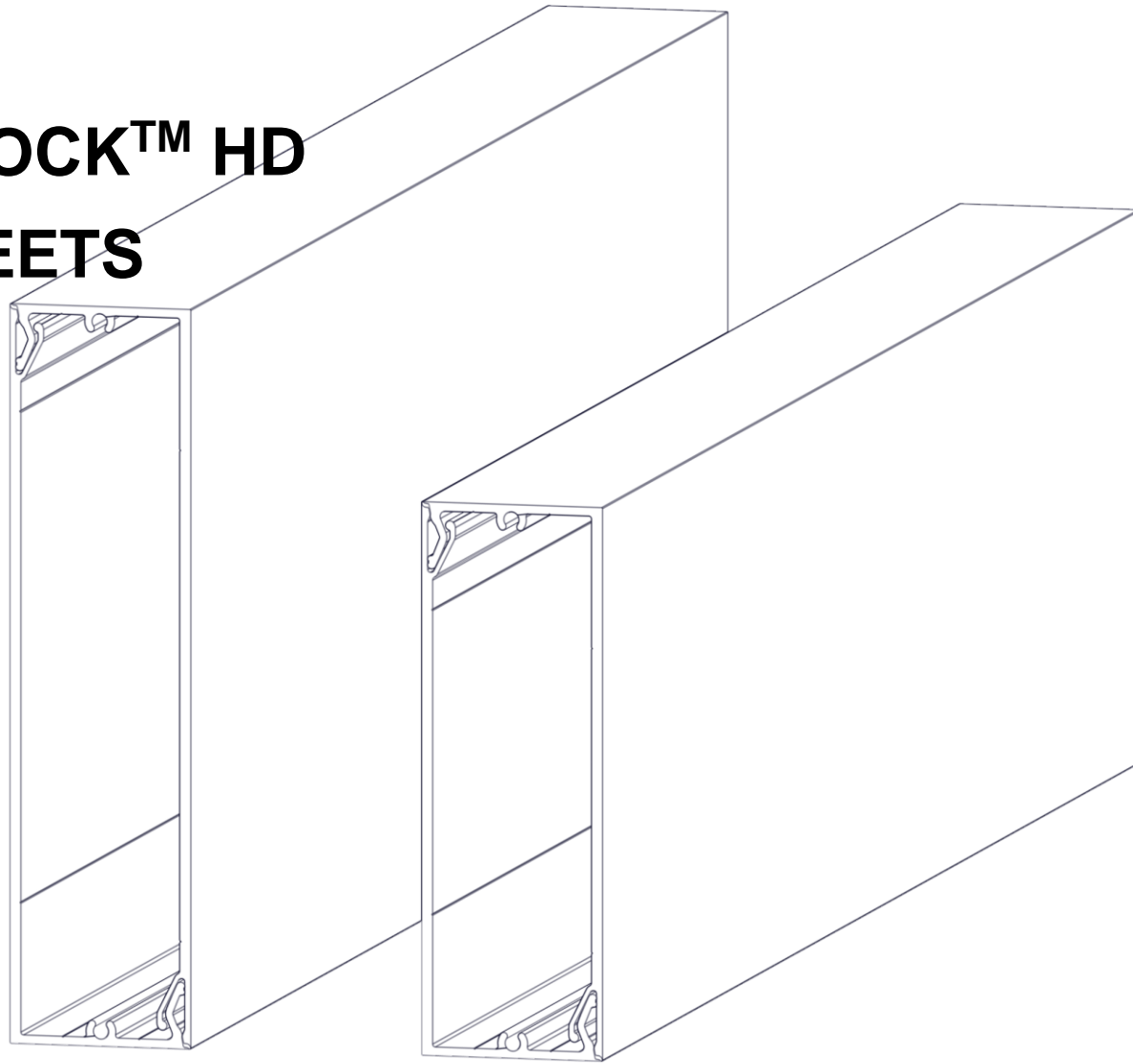

L&L HD Components

Finishes:
Woodgrains, Solid, Specialty
Custom Solid Color Matching - (Additional lead times apply)



4" Link & Lock HD



6" Link & Lock HD

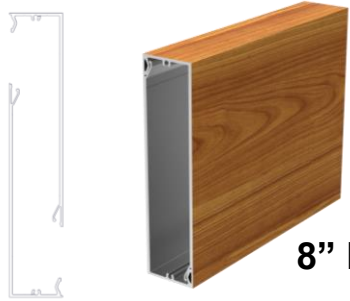

8" Link & Lock HD



Link & Lock HD End Mount

Actual Sizes & Weights

L&L	Width	Depth	Length	Weight(lbs/LF) *per set
4"	4" (101.6mm)	2" (50.8mm)	12'/24'	1.7
6"	6" (152.4mm)	2" (50.8mm)	12'/24'	2.4
8"	8" (203mm)	2" (50.8mm)	12'/24'	3

Size	12'	24'	End Caps (20/box)	End Mounts (20/box)
4"	2X4LLHD.145	2X4LLHD.289	2LLHDEC.4	2LLHDEM.4
6"	2X6LLHD.145	2X6LLHD.289	2LLHDEC.6	2LLHDEM.6
8"	2X8LLHD.145	2X8LLHD.289	2LLHDEC.8	2LLHDEM.8

Mounting Accessories	Qty	SKU
Link & Lock Mounting Clip	48, bag	LLMC.N48
Link & Lock™ Isolation Washer	48, bag	FAST.5003.BOX48
Dewalt® 1/2" Pilot Point Drill Bit	1	DRILLBT.05

Physical data:

- 6063-T5 Extruded Aluminum
- 100% recyclable
- Warranty on Finish: 15 year (standard)/20 year* (ultra) (*10week lead time); Aluminum: 50 year

BIM & CAD:

- RVT & DWG files to be available

Mounting Clip:



- Nylon with embedded SS washer
- Used on Batten and Fin orientation to secure the back "L" to the substrate
- Included in order with L&L for 6' O.C. attachment
- Additional Clips purchased separately (48 pcs/bag)

1/2" Pilot Point Drill Bit:



- 1/2" Pilot Point Drill Bit
- Used for Drilling out the holes for mounting the L&L to the substrate
- See Install Guide for drilling details

Isolation Washer:



- PA6 Nylon
- Used to isolate the back "L" from the substrate
- Max. 4x to shim L&L (1/4" total)
- 1/16" thick, 1 1/2" O.D.
- Purchased separately in packages of 48

#14 Fastener



- Eng. & Load Dependent (By others):
- Zinc-plated or Stainless Steel
- Used for attaching the back "L" to the substrate
- Use the correct fastener for the required project substrate
- Supplied by others

L&L HD Installation, Testing Data & Allowable Spans See L&L Install Guide for details

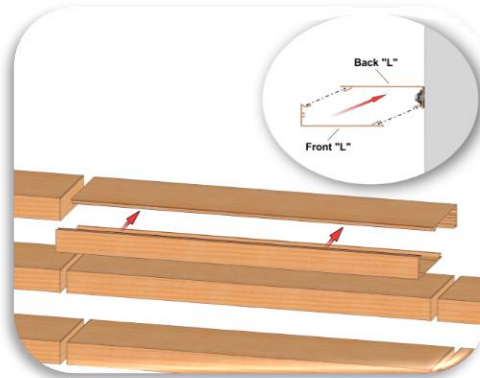
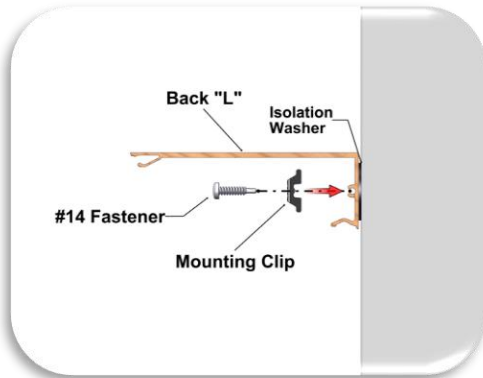

**Fastening
Fin Orientation**



**Fastening
Batten Orientation**

Testing: (In Development)

ICC-ES Evaluation Report -
Division: 05 00 00 – METALS

- Section: 05 50 00 - Metal Fabrications

LARR - Los Angeles Department of Building Safety (LADBS) accepts ICC-ES reports as proof of compliance

International Building Code (IBC)
International Residential Code (IRC)
California Building Code (CBC)
California Residential Code (CRC)
City of Los Angeles Building Code (LABC)
City of Los Angeles Residential Code (LARC)
Florida Building Code – Building
Florida Building Code - Residential

☀️ Light Reflectance: 5% (Black) up to 73.2% (Ultra White)

🔥 Fire Rating: Class A Non-Combustible by ASTM E136 & ASTM E84

LONGBOARD®
INSPIRING ARCHITECTURE

4" LINK & LOCK HD	PSF (FACTORED/ULTIMATE)										
	30	40	50	60	70	80	90	100	110	120	
ALLOWABLE SPAN (ft)											
6'											
8'											
10'											
12'											

All testing has been performed using L/180 deflection limits

LONGBOARD®
INSPIRING ARCHITECTURE

6" LINK & LOCK HD	PSF (FACTORED/ULTIMATE)										
	30	40	50	60	70	80	90	100	110	120	
ALLOWABLE SPAN (ft)											
4'											
6'											
8'											
10'											
12'											

All testing has been performed using L/180 deflection limits

LONGBOARD®
INSPIRING ARCHITECTURE

8" LINK & LOCK HD	PSF (FACTORED/ULTIMATE)										
	30	40	50	60	70	80	90	100	110	120	
ALLOWABLE SPAN (ft)											
4'											
6'											
8'											
10'											

All testing has been performed using L/180 deflection limits



LONGBOARD®
INSPIRING ARCHITECTURE

LINK & LOCK™ BRACKETS INFO SHEETS

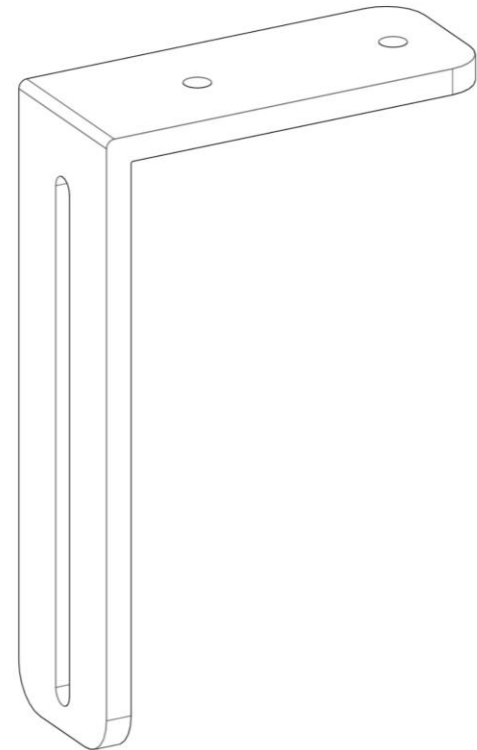
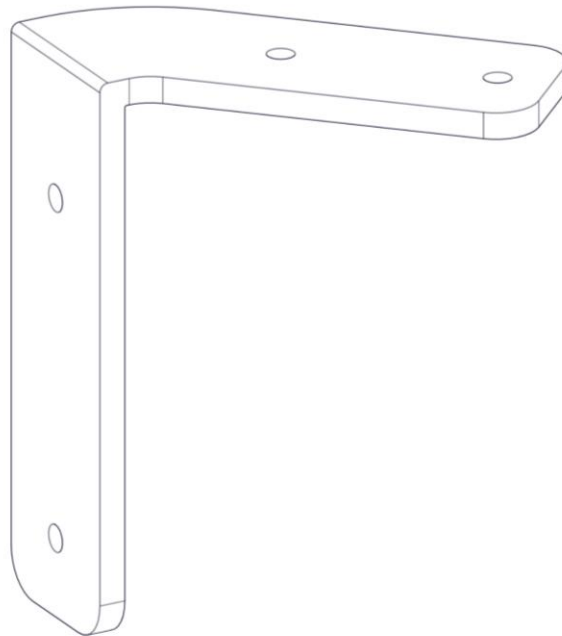
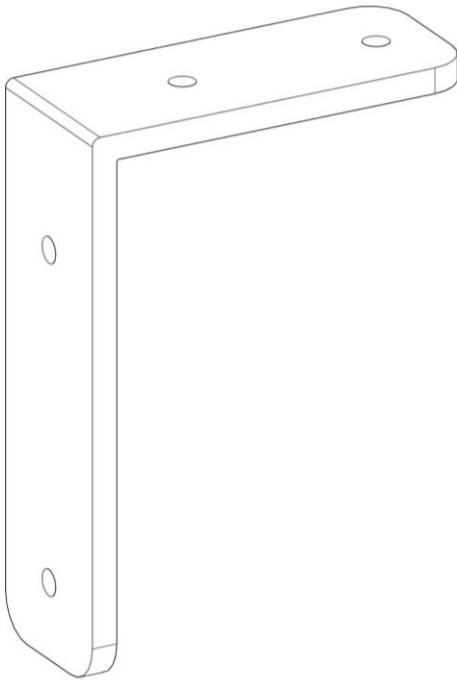

L&L Bracket Components

Single Bracket for horizontal substrate

Fixed Bracket (Hard fastened with 1/4" holes)

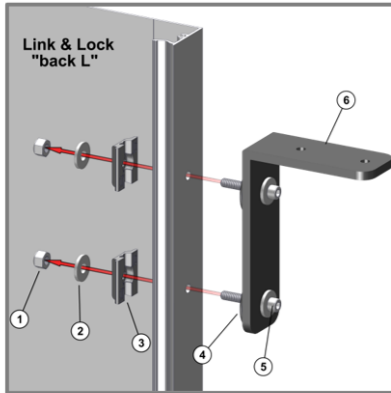

Fixed Bracket (Expansion 1/2" holes)

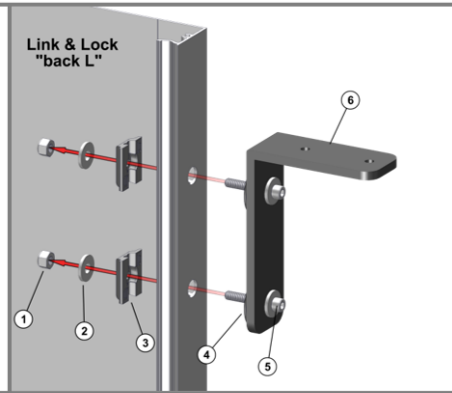

Dual Bracket for vertical substrate

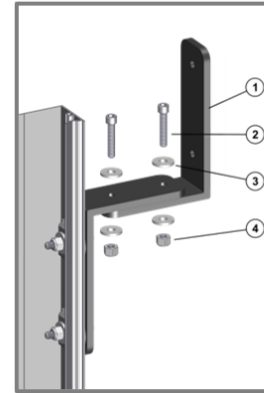

Dual Bracket components are pre-assembled by manufacturer. Do not adjust or remove unless authorized by the manufacturer.

No.	Description	Material	Qty
1	Link & Lock Dual Bracket -90 Center Fixed	6005A Aluminum	1
2	1/4" -20 Socket Head Screw, 1-1/4" length	Stainless Steel	2
3	Washer, 1/4" screw size, 0.75" OD	Stainless Steel	4
4	1/4" -20 Locknut	Stainless Steel Nylon-Insert	2

No.	Description	Material	Qty
1	1/4" -20 Locknut	Stainless Steel Nylon-Insert	2
2	Washer, 1/4" screw size, 0.75" OD	Stainless Steel	4
3	Link & Lock Mounting Clip	Nylon w. Stainless Washer	2
4	Self-Retaining Washer for 1/4" size	Nylon, Black	2
5	1/4" -20 Socket Head Screw, 1-1/2" length	Stainless Steel	2
6	Link & Lock Bracket -90 Center Fixed	6005A Aluminum	1

Sliding Bracket (Use 1/4" holes)

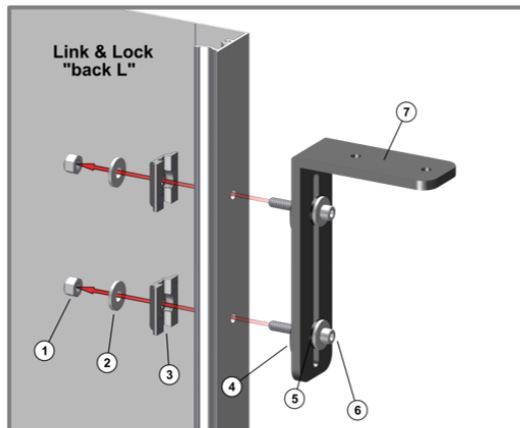

Link & Lock™ Mounting Brackets

Product	Single	Dual
45° LEFT FIXED	LLMBK.45LF	LLMDK.45LF
45° RIGHT FIXED	LLMBK.45RF	LLMDK.45RF
90° CENTER FIXED	LLMBK.90F	LLMDK.90F
45° LEFT SLIDING	LLMBK.45LS	LLMDK.45LS
45° RIGHT SLIDING	LLMBK.45RS	LLMDK.45RS
90° CENTER SLIDING	LLMBK.90S	LLMDK.90S



No.	Description	Material	Qty
1	1/4" -20 Locknut	Stainless Steel Nylon-Insert	2
2	Washer, 1/4" screw size, 0.75" OD	Stainless Steel	4
3	Link & Lock Mounting Clip	Nylon w. Stainless Washer	2
4	Self-Retaining Washer for 1/4" screw size	Nylon, Black	2
5	Plastic Washer, 1/4" screw size, 0.734 OD	Nylon, Black	2
6	1/4" -20 Socket Head Screw, 1-1/2" length	Stainless Steel	2
7	Link & Lock Bracket -90 Center Sliding	6005A Aluminum	1

L&L Bracket Dimensions

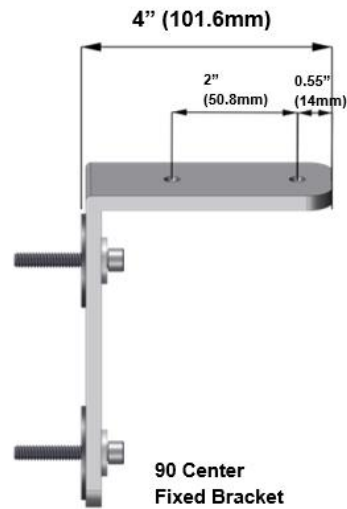
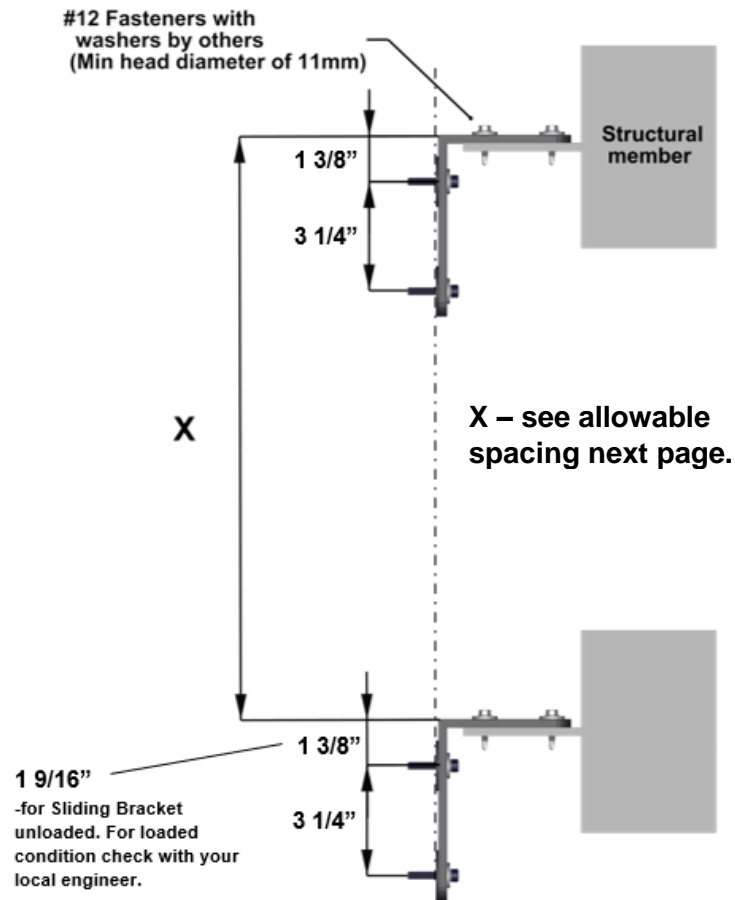

Tools for Bracket Install to L&L



7/16" Nut Driver
Fixed & Sliding
Brackets



3/16" Allen Key
Fixed & Sliding
Brackets

L&L Bracket Installation, Load Data & Allowable Spacing

See [L&L Install Guide](#) for details

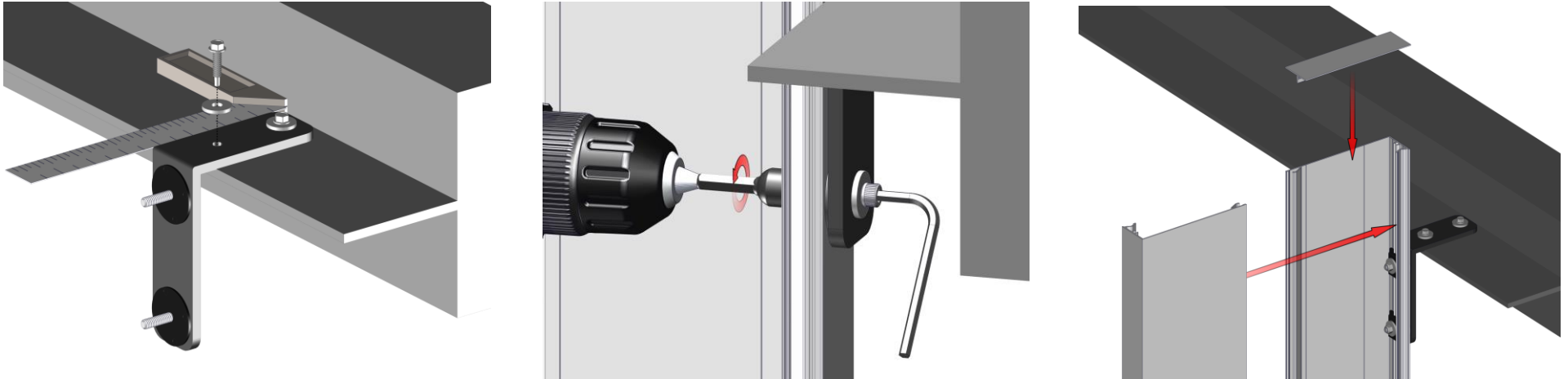

LINK & LOCK™ BATTEN	LINK & LOCK™ BRACKET MAX. SPACING (FT)									
	WIND LOAD PSF (FACTORED/ULTIMATE)									
	30	40	50	60	70	80	90	100	110	120
1-5/8" x 2"	10'	8'	6'	6'	4'	4'	2'	2'	2'	2'
1-5/8" x 4"	8'	6'	4'	4'	2'	2'	2'	2'	2'	2'
1-5/8" x 4" w. Internal Stiffener	12'	10'	8'	6'	6'	4'	4'	4'	4'	4'
1-5/8" x 6"	6'	4'	4'	3'	3'	3'	2'	2'	2'	2'
1-5/8" x 6" w. Internal Stiffener	10'	8'	6'	4'	4'	3'	3'	3'	2'	2'
1-5/8" x 8"	6'	4'	2'	2'	2'	2'	2'	2'	2'	2'
1-5/8" x 8" w. Internal Stiffener	8'	6'	4'	4'	3'	3'	2'	2'	2'	2'
2" x 4" HD	12'	10'	8'	6'	6'	4'	4'	4'	4'	4'
2" x 6" HD	10'	8'	6'	4'	4'	3'	3'	3'	3'	3'
2" x 8" HD	8'	6'	4'	4'	3'	3'	2'	2'	2'	2'

Recommended torque value for Link & Lock™ to Bracket attachment:

note 1 Factored Wind Load: max. 168 LBS/EA Bracket

note 2 Factored Dead Load: max. 29 LBS/EA Fixed Bracket

note 3 Fixed Bracket 1/4" -20 Socket Head Screw, 60-72 in/lbs + prevailing torque of self-locking nut

note 4 Sliding Bracket 1/4" -20 Socket Head Screw, 48-60 in/lbs + prevailing torque of self-locking nut

April 25, 2024