



**LONGBOARD®**  
INSPIRING ARCHITECTURE



# Panelboard™ Soffit

Installation Guidelines

## Table of Contents

<b><u>Material Specifications</u></b>	<b>3</b>
Finishes	3
Expansion and contraction	3
Material ordering and deliveries	3
Storage and handling	3
Cleaning	4
Warranty	4
Graffiti Removal	4
<b><u>Components</u></b>	<b>5</b>
Components (Typical)	5
<b><u>Tools/Cutting/Fastening</u></b>	<b>6</b>
Tools	6
Cutting	6
Fastening	7
Fastener types	7
Framing requirements	7
Furring recommendations	8
<b><u>System Install</u></b>	<b>9</b>
Perimeter and field area limitations	9
Component layout	10
J-Track	10
Starter J-Track	10
U-Reveal Set	10
T&G U-Reveal	10
Termination Set	10
Install Steps	11-17
Details	18
Butt-Joints	18
<b><u>Appendix</u></b>	<b>19</b>
Tables - Expansion & contraction	19
Tables - Quick Screen clip/wind load	20
Handling and care of products	21
Contact Info	22

## Material Specifications

### Finishes

- Longboard Products are available in a wide range of woodgrains and solid colors
- Custom solid colors are available upon request
- Longboard woodgrains have a repeat pattern, shipped in sets mated back-to-back in each box. Install these as they come out of the box, as an A&B pattern (need to assess onsite), staggering each plank approx. 1-2' (305-610mm) from the previous plank to achieve a random pattern aesthetic.
- Longboard Products are not recommended for use on marine applications in direct contact with salt water.

Longboard extruded products are produced 1" (25mm) oversized, as one end is drilled for the coating process, and both ends have 1/2" (12mm) of masking tape (woodgrains only) which must be cut off for best results.

Longboard Cladding is to be installed outboard of a weather resistant barrier, including all flashings, following code, and building requirements.

### Expansion & Contraction

Planks & components expand & contract 1/4" (6mm) over 24' (7.3m) in all directions, measured over a 30°C (54°F) temperature range. Due to this range of movement, the following expansion components should be installed perpendicular to planks every:

- 
- 24' (7.3m) max<sup>1</sup> Perpendicular to Planks: Traditional Flat Reveal, U-Reveal Set

<sup>1</sup>Note: 40' (12.2m) max if using staggered butt-joints.

Other options (Perpendicular to Planks only)

- 
- 12' (3.7m) -Craftsman U-Reveal Set
  - 6' 8" (2m) -Precision Flat Reveal

When using expansion components, each plank must terminate into a minimum of one (1) component to allow for expansion & contraction.

**See: Appendix for tables of expansion/contraction calculations per foot/meter of material.**

### Material Ordering & Delivery

- 
- **Packaging:** Planks are sold in box quantities:  
6" Smooth: 96 SQ FT/Box (8/24's) w. 90pcs Quick-Screen Clips included  
Components are sold individually by the 12' (3.7m) length.
  - **Shipping:** Most Popular Finishes -ready to ship within 1 week  
Additional Finishes -ready to ship within 14 weeks  
Delivered on 24' (7.3m) long skids weighing up to 2000 lbs. A mechanical lift with forks is required on site to receive the order.
  - **QC:** Always inspect the delivery for damage and contact LB ASAP if there are any issues: [info@longboardproducts.com](mailto:info@longboardproducts.com) or 1-800-604-0343 and include your PO# and any pictures if possible. Mark the delivery receipt as "damaged" and accept the delivery as-is. Longboard is not responsible for the installation of blemished or damaged material.

### Storage & Handling

Be sure to store the material flat, keep it dry, safe & secure and remain in unopened cartons until ready to be installed.

**See Appendix for proper handling and care instructions.**

### Cleaning Recommendations

- Initial and periodic cleaning for best looking product
- Basic methods use a combination of moderate water pressure, soft sponge/brush and a mild detergent (Safe for your hands, safe for the product)

⚠ NEVER use aggressive acid or alkaline cleaners on Longboard finishes. Do not use cleaners containing Trisodium Phosphate, Phosphoric Acid, Hydrochloric Acid, Hydrofluoric Acid, Fluorides, or any other compound that is known to react with metal.

**\*See Cleaning Guide for full requirements & cleaning schedule:**

[longboardproducts/resources/care-maintenance.com](http://longboardproducts/resources/care-maintenance.com)

### Warranty

Upon substantial completion of the project, register for warranty online here: [longboardproducts.com/warranty](http://longboardproducts.com/warranty)

⚠ Registration is required for the warranty to be in effect.

### Graffiti Removal

**Standard Woodgrain**

Use Standard soap & water only

**D2000 Solid Color**

	Prosoco Cleaner	MEK Solvent	
Permanent Marker	<input checked="" type="checkbox"/>	<input checked="" type="checkbox"/>	 MEK Solvent   Prosoco Anti-Graffiti Cleaner
Oil Based Spray Paint	<input checked="" type="checkbox"/>	<input checked="" type="checkbox"/>	
Water Based Spray Paint	<input checked="" type="checkbox"/>	<input checked="" type="checkbox"/>	
Adhesive Tape	<input checked="" type="checkbox"/>	<input checked="" type="checkbox"/>	

**SPECIAL ORDER - EXT. LEAD TIMES CONTACT LB**

**Anti-Graffiti High Gloss Woodgrain**

	Prosoco Cleaner	MEK Solvent	
Permanent Marker	<input checked="" type="checkbox"/>	<input checked="" type="checkbox"/>	 MEK Solvent
Oil Based Spray Paint	<input checked="" type="checkbox"/>	<input checked="" type="checkbox"/>	
Water Based Spray Paint	<input checked="" type="checkbox"/>	<input checked="" type="checkbox"/>	
Adhesive Tape	<input checked="" type="checkbox"/>	<input checked="" type="checkbox"/>	

Note: Cleaning the surface with a cleanser that is not diluted as per instructions, may result in damage to the coating.

## Components

### Components (Typical)







The Panelboard™ system consists of many components used in conjunction with each other to create a panelized look. For all LB components go to [longboardproducts.com](http://longboardproducts.com).

 <p><b>6" Smooth Plank</b> 6PSP.289</p>	 <p><b>J- Track</b> 1JT.145</p>	 <p><b>Two Piece J-Track</b> 1X1JT.145</p>	 <p><b>Starter J-Track</b> 1SJT.145</p>
 <p><b>T&amp;G U-Reveal</b> 2TGURK.289</p>	 <p><b>U-Reveal Set</b> 2URS.145</p>	 <p><b>Termination Set</b> 1TS.145</p>	

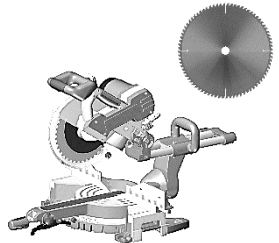
## Tools/Cutting/Fastening

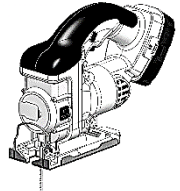
### Tools

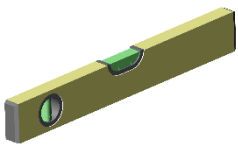
Commonly used tools for Panelboard Soffit install.

			
Table Saw with Carbide Metal Blade Non-ferrous 60-80T (for cutting aluminum)	Miter Saw with Carbide Metal Blade Non-ferrous 60-80T (for cutting aluminum)	Cordless Drill with clutch	Jig Saw (for protrusions)
			
Rubber Mallet (or Hammer)	Level	Hole Saw (for lighting fixtures)	#8 Pan Head Screws <small>*Length, thread and point to suit substrate</small>

### Cutting

⚠ Always be sure to wear appropriate PPE: eye & hearing protection.

Cut planks using a Miter Saw and Table Saw, always allowing for expansion & contraction. Trim the taped/drilled ends of all stock length material by at least **1/2" (12mm) each end** and discard.

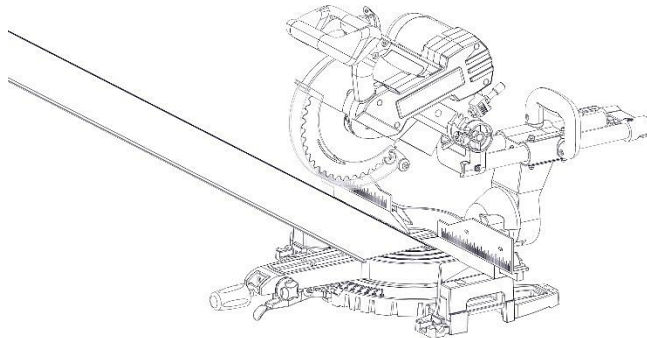

## Fastening

Fasteners must be corrosion resistant and comply with all local building codes.

⚠️ All fasteners should be suitable for exterior use and be compatible with the substrate type. **Fasteners should be anchored into a solid secure framing member, blocking, furring, or strapping. For any applications when the framing member is not available, install furring strips or metal strapping to securely fasten planks.**

**Perimeter components** should be hard fastened every **16" (406mm) O.C.** directly through the flange using #8 pan-head screws (supplied by others). These components should be fastened within **8" (203mm)** of the end for secure fastening.

**Planks & starter components** are secured using Longboard **Quick-Screen Clips** fastened to the substrate using #8 pan-head screws (supplied by others).

### Standard wind loads

- Typically, every **32" (813mm) O.C.**

### Higher wind loads

- Typically, every **16" (406mm) O.C.**

⚠️ Always consult the project engineer, architect or authority having jurisdiction to understand the project specific fastening requirements.

See **Appendix for fastener specs:**

**Quick Screen Clip - Wind Load Tables 3 & 4**

## Framing requirements

Always consult the local building authority and follow local building code requirements.

### Wood Framing

- Size: 2x4 minimum
- Spacing: see Appendix Table 3 & 4 for reference

### Metal Framing

- Gauge: 20 ga. minimum (see Appendix Table 3 & 4 for reference)
- Spacing: see Appendix Table 3 & 4 for reference

## Fastener types

### RECOMMENDED

#### Pan-Head



\*Length, thread and point to suit substrate

### CORRECT

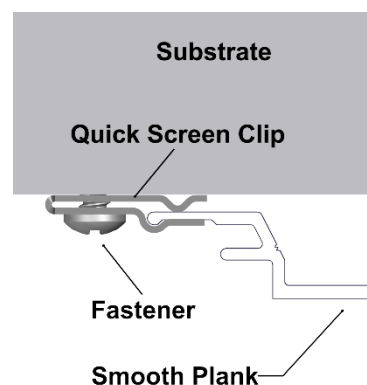

### DO NOT USE

#### Flat-Head    Oval-Head

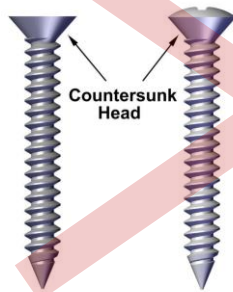

### INCORRECT

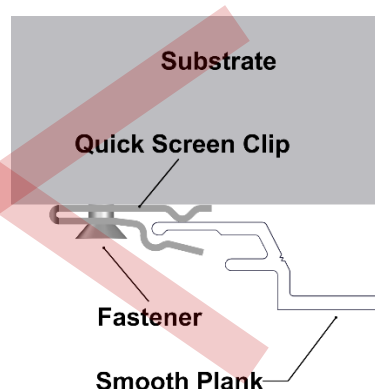

## Furring recommendations

### Wood Furring

Attached back to wood or metal framing/blocking.

- Size: 3/8" minimum
- Spacing: See Appendix Table 3 & 4 for reference

### Metal Furring/Strapping

Attached back to wood or metal framing/blocking.

- Size: 20 ga. minimum
- Spacing: See Appendix Table 3 & 4 for reference

### Concrete/CMU

Wood or metal furring is recommended over concrete and CMU.

Wood Furring:

- Size: 2x2 minimum
- Type: Pressure treated lumber
- Spacing: See Appendix Table 3 & 4 for reference

Metal Furring:

- Size: 20 ga. minimum (See Appendix Table 3 & 4 for reference)
- Type: Hat channel, Stud, or Z-Girt.
- Spacing: See Appendix Table 3 & 4 for reference



**Perimeter and field area limitations**

- Measure and layout your wall area to consider plank & component alignment with fixtures, penetrations, and adjacent walls and edges, for desired appearance. Consider using butt-joints along runs to minimize waste.
- Longboard system typical dimensions:
 

Planks width	- 6" (152mm)
Planks depth	- 1/2" (12mm)
Planks and Quick-Screen Clips depth	- 9/16" (14mm)
Trim Components depth	- 5/8" (15mm)

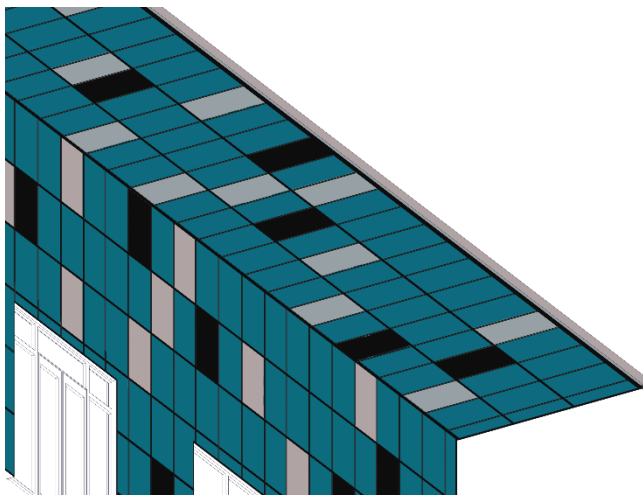
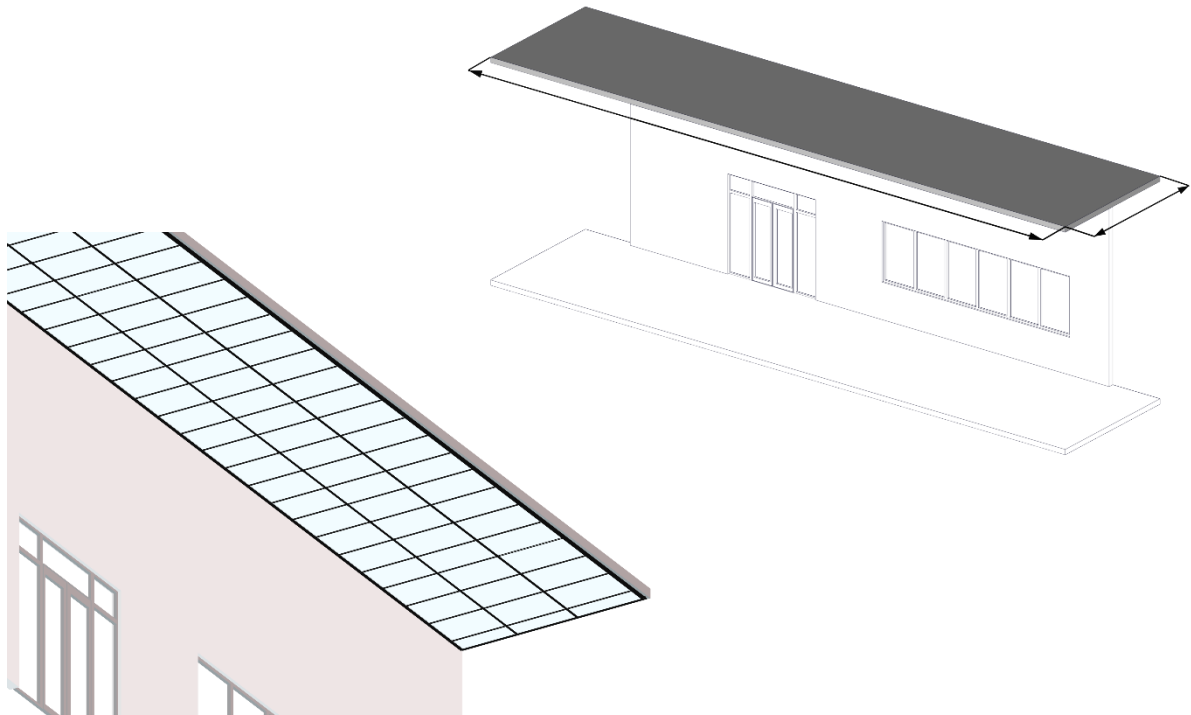

## Component layout

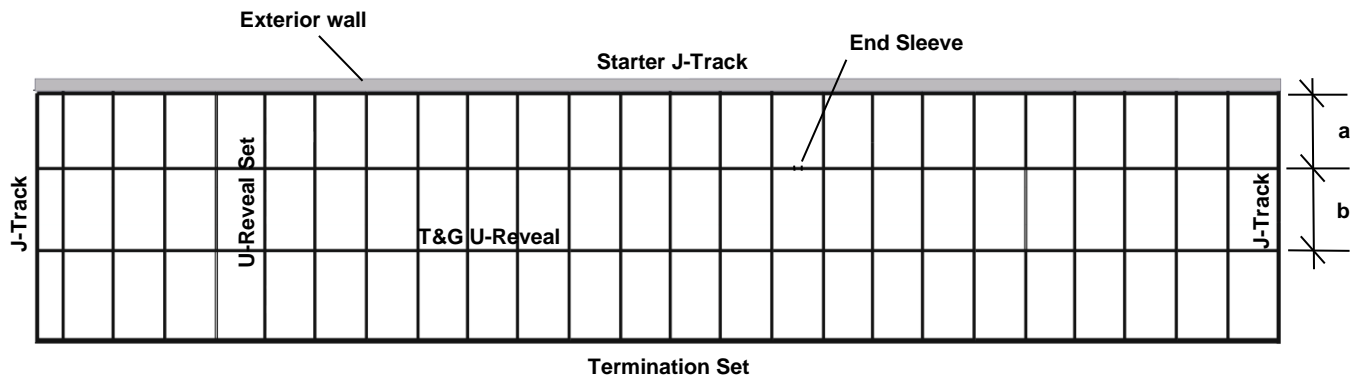

Measurement considerations:

### 1 1/2" (38mm) T&G U-Reveal (up to 24' length panels)

- (a) Start to Panel - Measuring from outer edge of the Starter J-Track to the center of the 1 1/2" U-Reveal, add 5/8" (16mm) to the dimension of the Plank area. =  $6"(X) + 5/8"$  to  $\phi$
- (b) Panel to Panel - Measuring from center to center of the 1 1/2" U-Reveal, add 1" (25mm) to the dimension of the Plank area. =  $6"(X) + 1"$  to  $\phi$

### 3/4" (19mm) T&G U-Reveal (up to 12' length panels)

- (a) Start to Panel - Measuring from outer edge of the Starter J-Track to the center of the 3/4" U-Reveal, add 1/4" (6mm) to the dimension of the Plank area. =  $6"(X) + 1/4"$  to  $\phi$
- (b) Panel to Panel - Measuring from center to center of the 3/4" U-Reveal, add 3/8" (10mm) to the dimension of the Plank area. =  $6"(X) + 3/8"$  to  $\phi$

## COMPONENTS -12' Stock lengths unless otherwise noted

### J-Track 5/8", Two Piece J-Track (5/8, 7/8", 1 3/8")

Location: Perpendicular to Planks (eg: sides of soffit areas), or around penetrations or cutouts.  
 Details: Notch the flange at the ends where they meet corner components.

### Starter J-Track 5/8", Starter Strip

Location: Where starting with a full width Plank, typically along the bottom of the installation for horizontal Planks.  
 Details: Alternatively, Back-to Back Starter can be used at the center of each soffit area for equal width ends.

### U-Reveal Set (3/4", 1 1/2")

Location: Perpendicular to Planks, used to set panelized widths.  
 Details: Two-piece component (cap & base).

### T&G U-Reveal (3/4", 1 1/2")

Location: Parallel to Planks, used to set panelized lengths.  
 Details: Single-piece component, use End Sleeve (included) every 24' max. (24' Stock lengths)

### Termination Set (5/8", 7/8", 1 3/8")

Location: Parallel to Planks along finish side of the installation area and other penetrations.  
 Details: Install base only to start and cap after planks are installed.

### Install steps

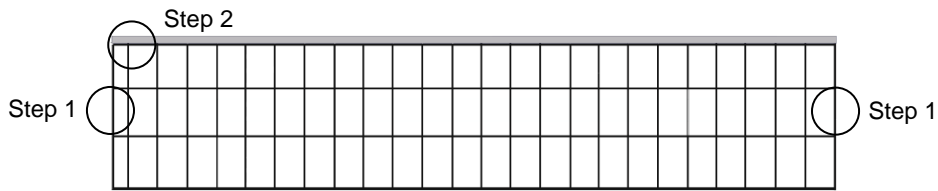

#### Step 1 - J-Track

Install J-Track or Two-Piece J-Track perpendicular to Planks (eg: sides of soffit areas), or around penetrations or cutouts. Fasten every 16" O.C. with #8 Pan Head Screws. Trims can be mitered for a clean corner look.

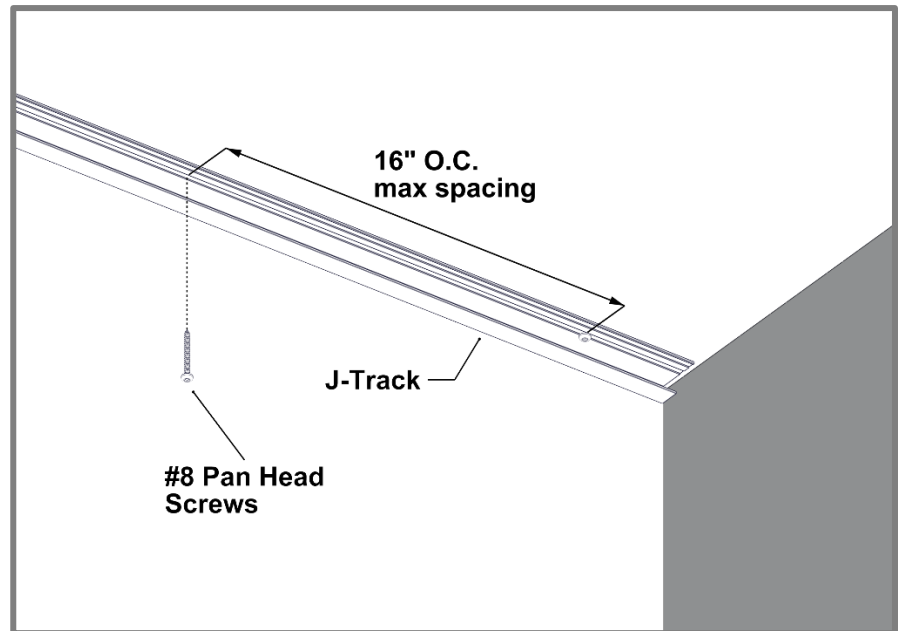

#### Step 2 - Starter J-Track

Install Starter J-Track or Starter Strip along the edge of the soffit(s), fastening every 16" O.C. with #8 Pan Head Screws. Notch the Starter J-Track to suit the trim component.

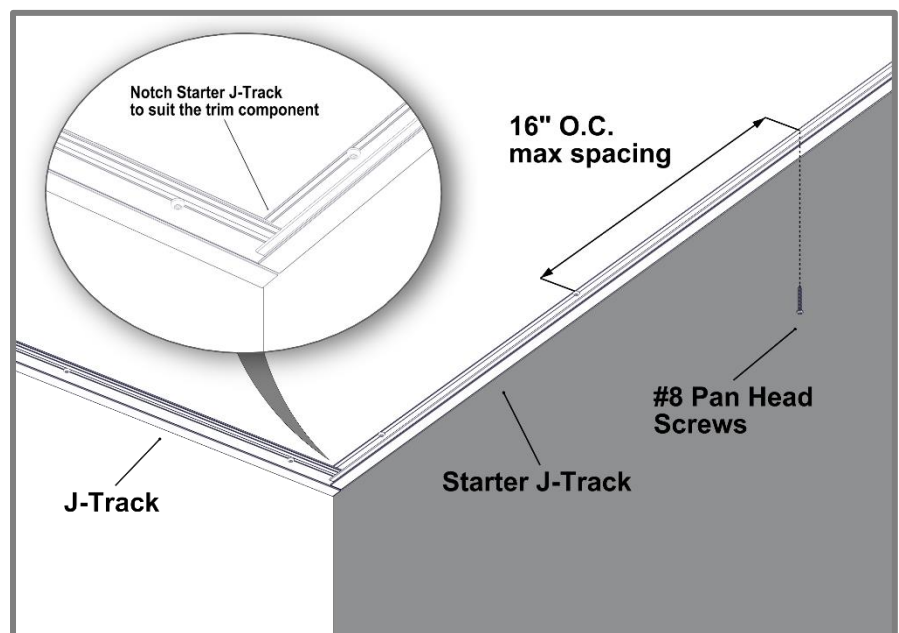

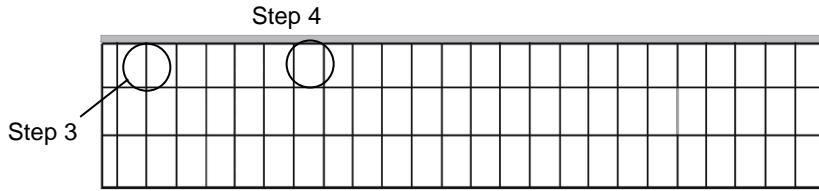

### Step 3 - U-Reveal

Install U-Reveal Set (base only) at the desired panelized length, fastening every 16" O.C. with #8 Pan Head Screws.

#### PLANK PREPARATION DURING INSTALL

1. **No** Taped/Drilled ends (cut off 1/2" each end).
2. **No** Damage/dents and correct plank sequence per project.
3. **Confirm** allowance for expansion/contraction & confirm trim/caps cover.

### Step 4 - Planks

Place the planks into the groove of the Starter J-Track, engaging the tongue. It is good practice to check your installation every 2-3 rows for level or plumb and flat or straight, for best results.

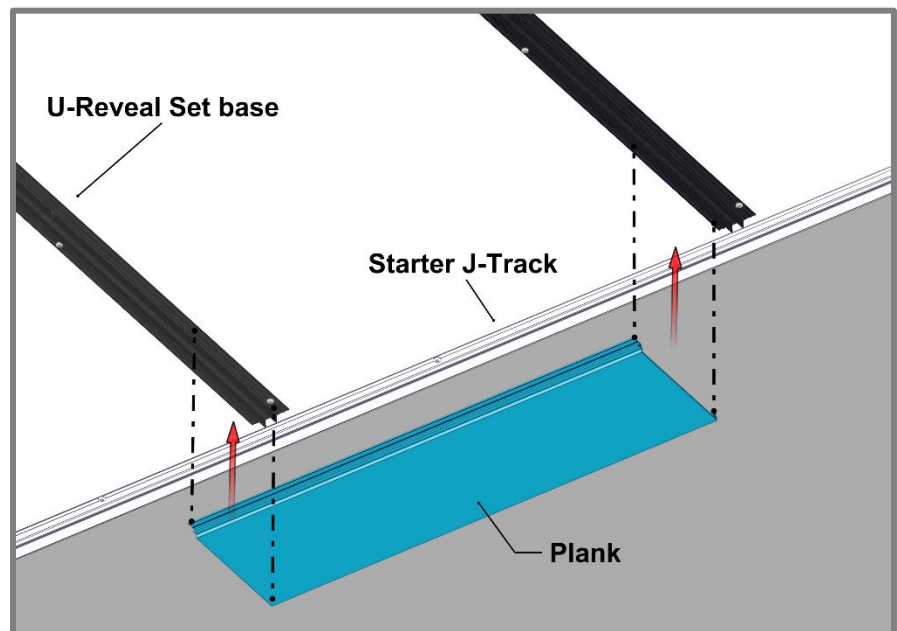
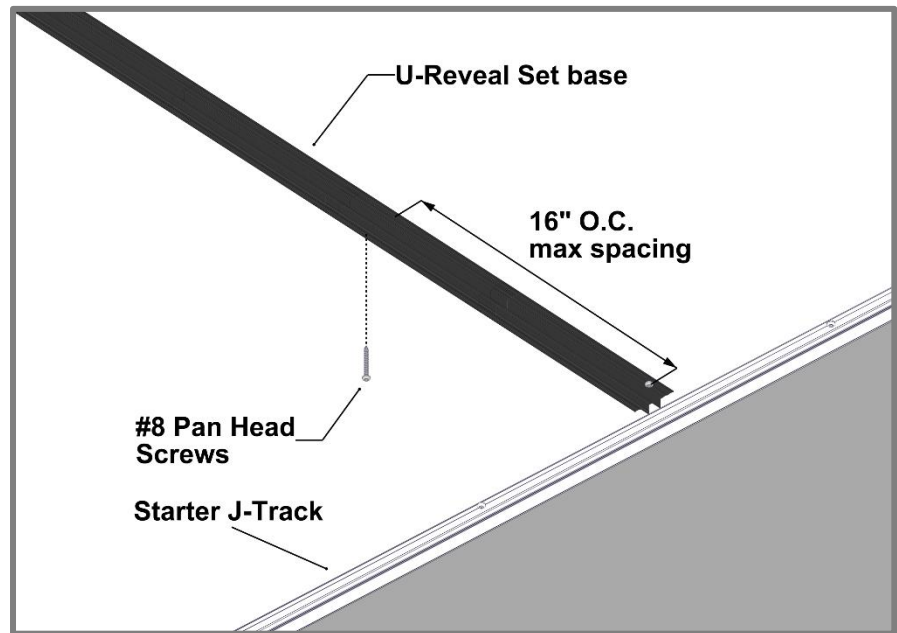

Ensure there is sufficient room for expansion and contraction of each Plank, also confirming component caps will cover.

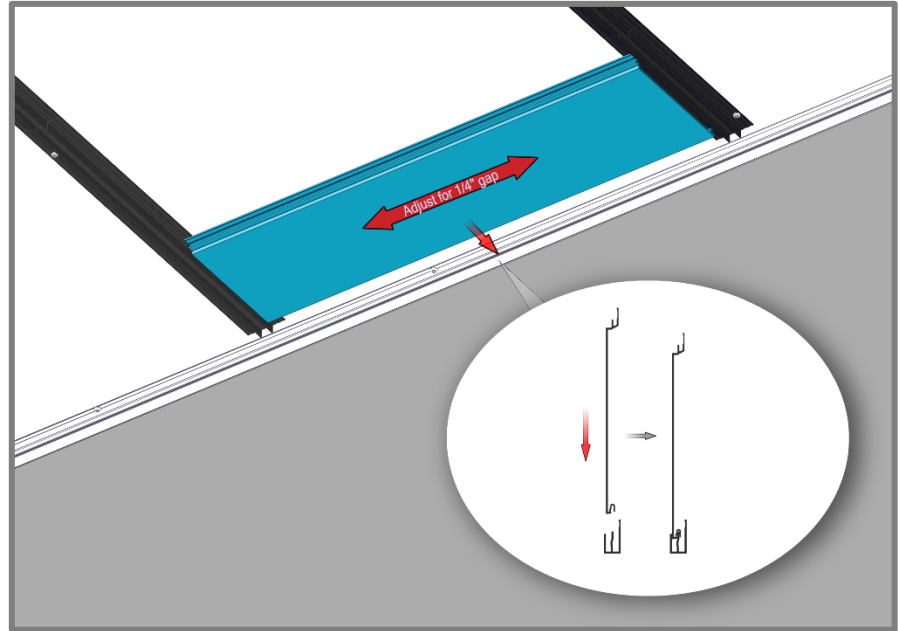

Install Quick Screen Clips every 32" (813mm) O.C. max spacing. Hard fasten only one point near the center of each plank or fasten at the butt-joints where butt-joints are used. Shim Quick-Screen Clips where needed to correct any substrate inconsistencies.

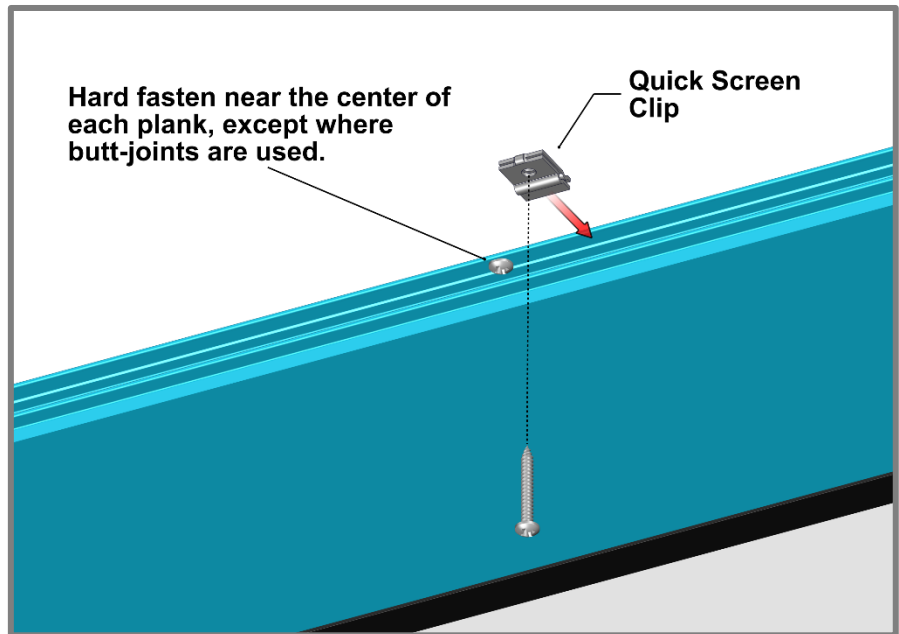

Where anchoring the planks securely can only be achieved over component flanges; split the Quick Screen Clip and use one piece on the front. This will maintain each Planks ability to expand and contract.

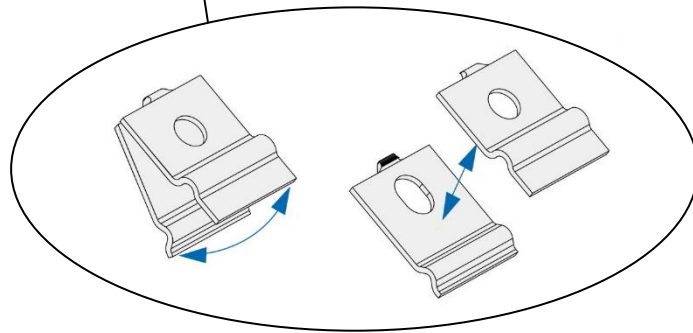
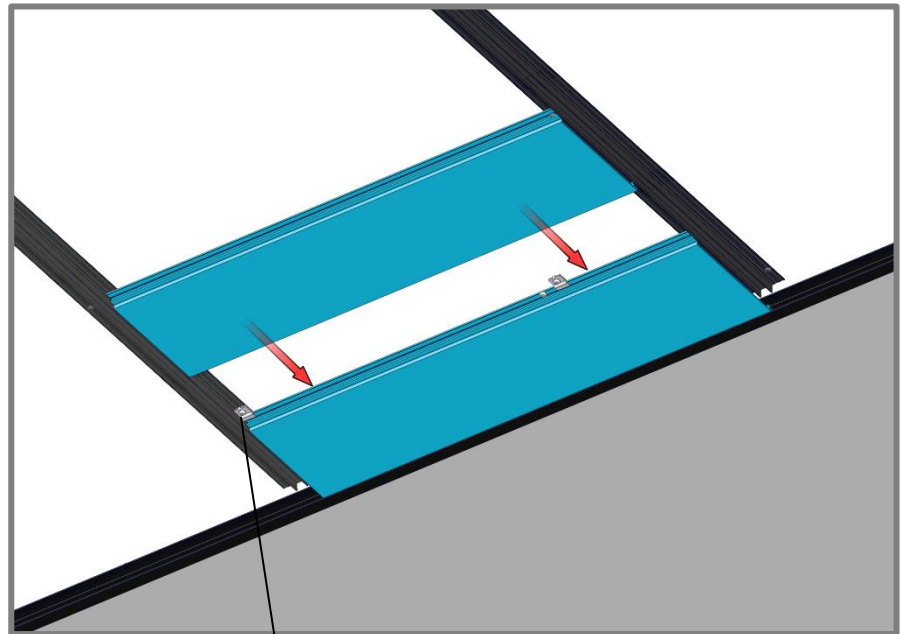

Step 5

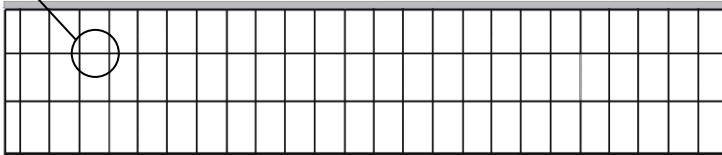

Step 5 - T&G U-Reveal

Install T&G U-Reveal at the Panelized width locking it into the tongue of the Planks.

**⚠ Do Not use fasteners or Quick-Screen Clips on Planks which engage with the groove side of the T&G U-Reveal.**

Fasten T&G U-Reveal with Quick Screen Clips and fasteners every 32" O.C. Hard fasten near the center of each T&G U-Reveal length. Where using multiple lengths of T&G U-Reveal, leave a 1/4" gap between butt-joints for thermal movement.

- Where using the Craftsman T&G U-Reveal (3/4"), install the included Craftsman End Sleeve to cover the 1/4" butt-joints. Use a small amount of structural silicone on a single side of the End Sleeve, leaving the opposite side dry and free to expand and contract.
- Where using the Traditional T&G U-Reveal (1-1/2"), install the included Traditional End Sleeve to cover the opposite side, free to expand and contract.

Step 6 – Next sections

Repeat install steps 3-5.

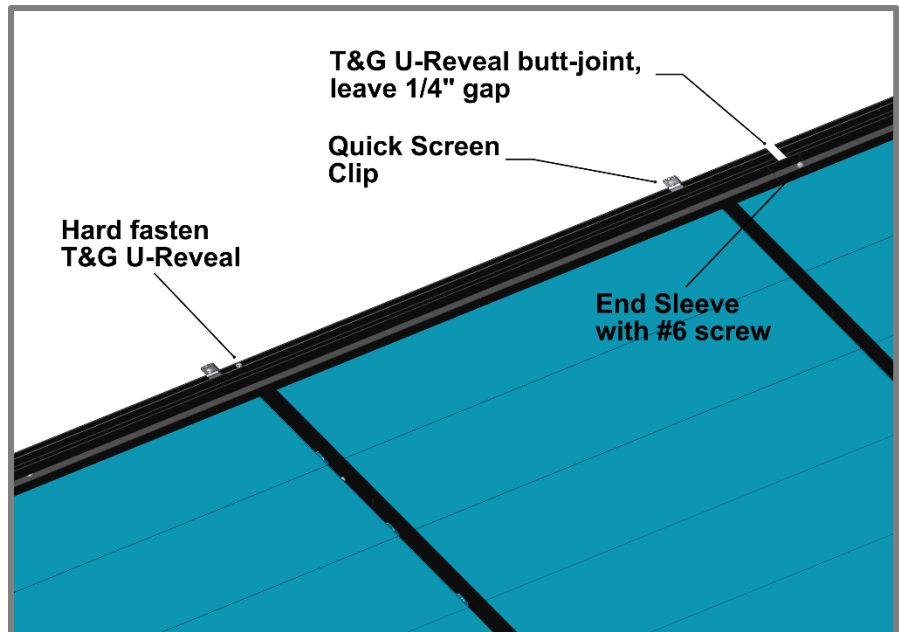
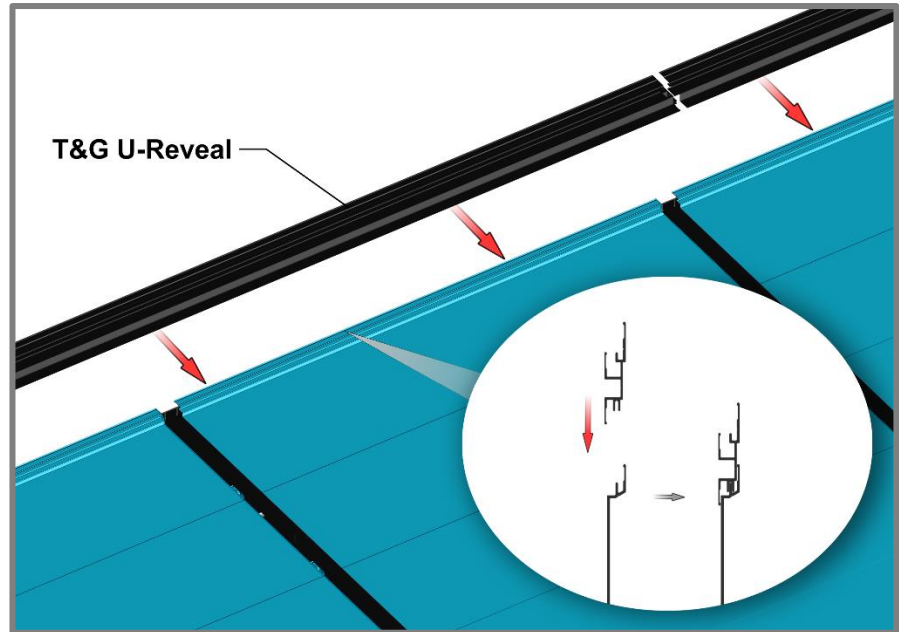

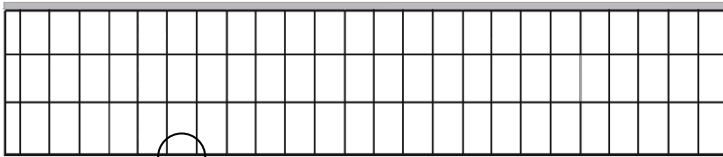

Step 7,8

**Step 7 – Termination Set**

Install Termination Set (base only), fastening every 16" O.C.

Where terminating cut planks, provide a positive stop approximately every 16" (406mm).

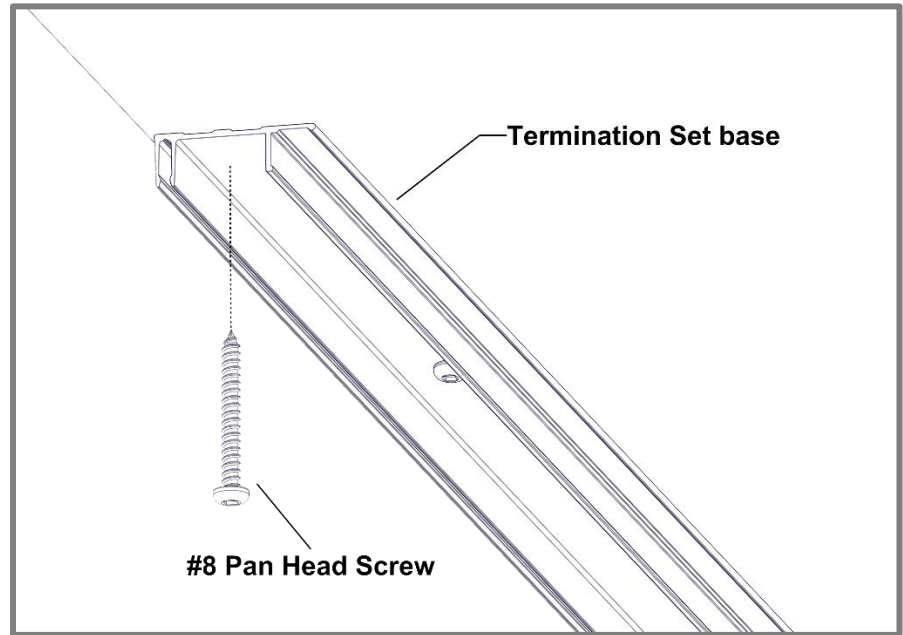

**Step 8 – Last Row of Planks**

Rip the last Plank, cutting it to width to suit the installation area(s). Install edge plank with a 1/4" gap and screw to lock the plank into place.

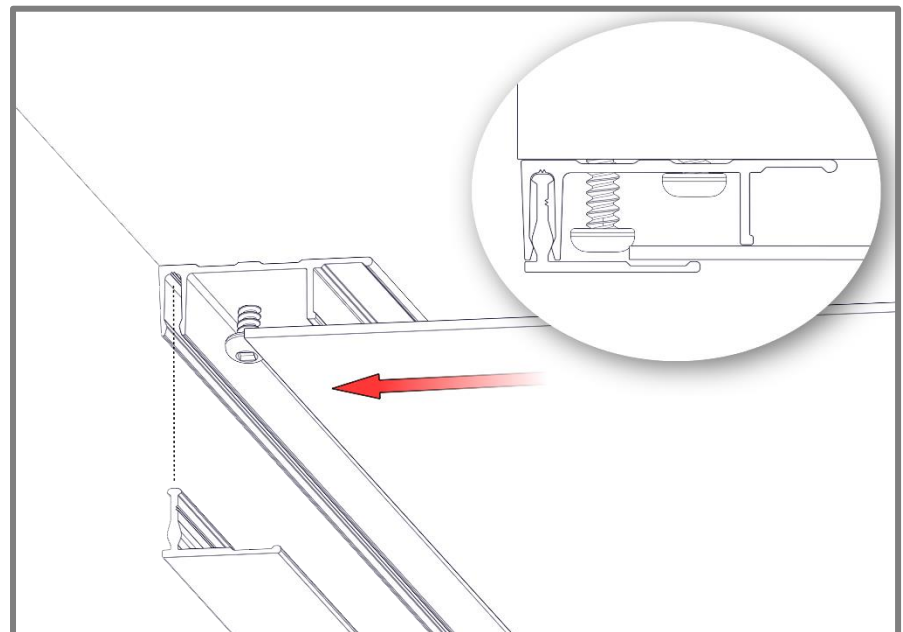



Step 9 - Once planks are installed, finish off the perimeter trims with caps from two-piece sets.

**Component Caps**

Location: Installed onto the base of the two-piece sets.

Details: If required, use a rubber mallet or hammer and block to protect the finish during this process.

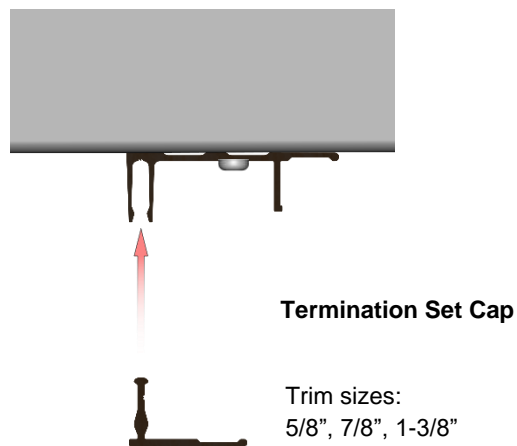
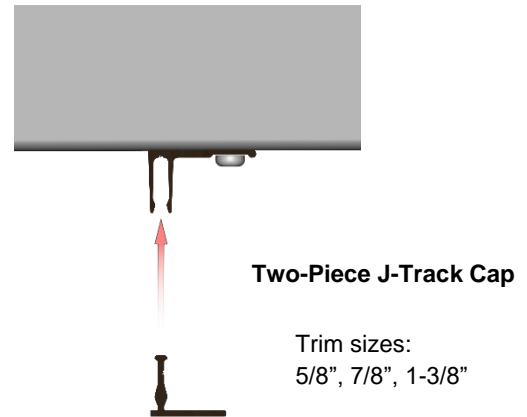
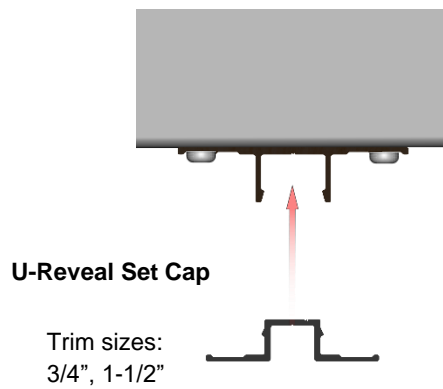

## Details

### Butt-Joints

- Consider using butt-joints along runs to minimize waste.
- ⚠ When installing staggered butt-joints, hard-fasten the two planks at the butt-joint to ensure joints do not open up (**See Detail A**). Fasteners should be placed at the uppermost location of the plank flange, to not interfere with the next plank engaging the tongue and groove properly. At the butt-joint, fasteners should be anchored into a 4" length of Starter Strip.
- On exposed cuts such as butt-joints, trim ends or similar, use touch-up paint pens (purchased separately) to finish the ends of the two (2) planks at the butt-joint.
- DO NOT install more than one (1) butt-joint between two components.
- DO NOT hard-fasten a plank to a component trim, as this will restrict its ability to expand & contract into the component.
- If no butt joints along the length, it is good practice to hard-fasten each plank directly through the flange near the center, to keep the planks from migrating.
- DO NOT hard-fasten more than one (1) location per plank.
- Fasten only:

Situation	Location
No butt-joints:	-Center of planks
Butt-joints:	-At the joints

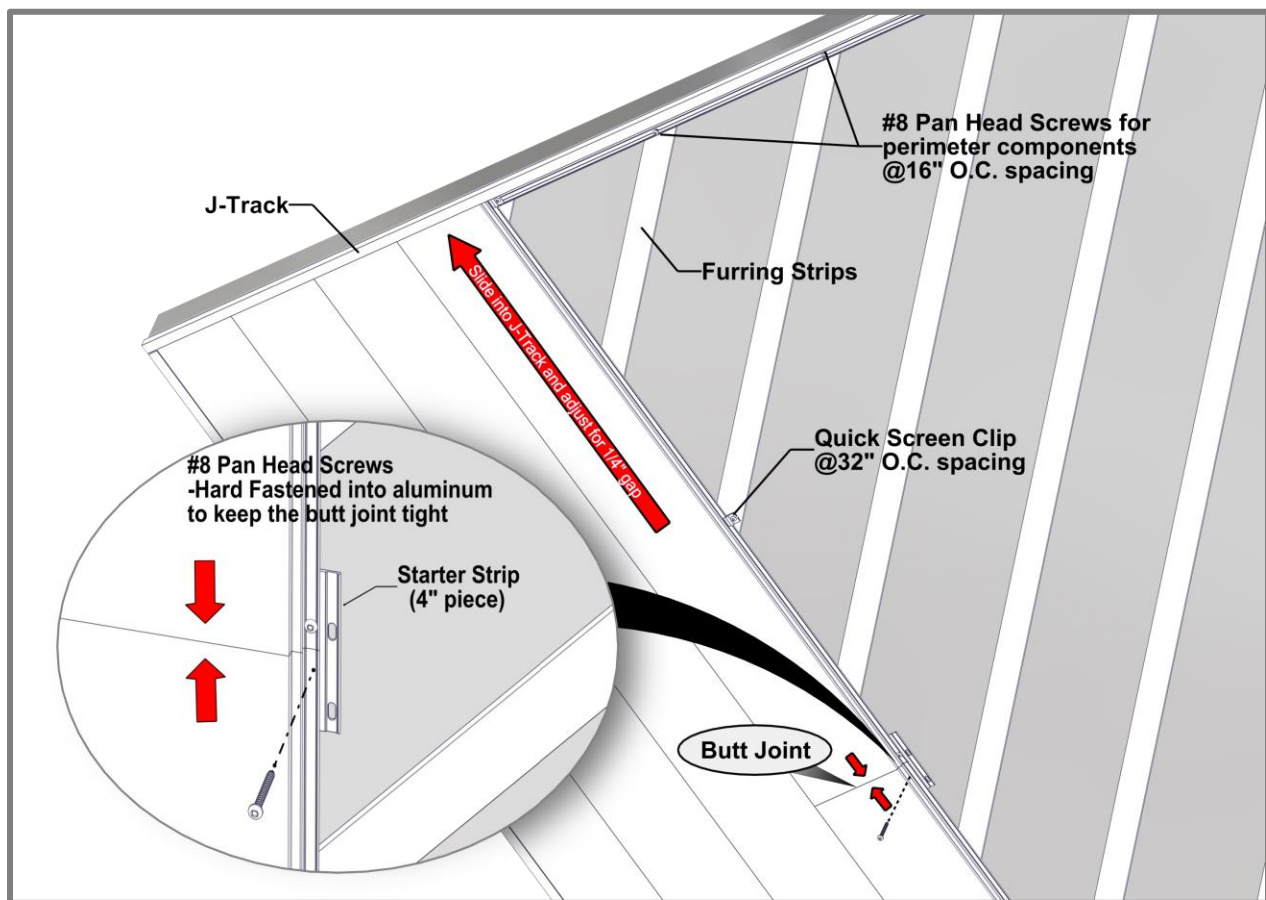

**Detail A**

# Appendix

## Expansion and Contraction Tables

TABLE 1 - IMPERIAL

		AVERAGE TEMPERATURE AT TIME OF CUTTING & INSTALLATION											
°C		-50	-40	-30	-20	-10	0	10	20	30	40	50	
°F		-58	-40	-22	-4	14	32	50	68	86	104	122	
MIN/MAX POST CONSTRUCTION TEMP.	°C	°F	EXPANSION OR CONTRACTION (INCH/FOOT)										
	-50	-58	0.000	-0.003	-0.005	-0.008	-0.011	-0.014	-0.016	-0.019	-0.022	-0.024	-0.027
	-40	-40	0.003	0.000	-0.003	-0.005	-0.008	-0.011	-0.014	-0.016	-0.019	-0.022	-0.024
	-30	-22	0.005	0.003	0.000	-0.003	-0.005	-0.008	-0.011	-0.014	-0.016	-0.019	-0.022
	-20	-4	0.008	0.005	0.003	0.000	-0.003	-0.005	-0.008	-0.011	-0.014	-0.016	-0.019
	-10	14	0.011	0.008	0.005	0.003	0.000	-0.003	-0.005	-0.008	-0.011	-0.014	-0.016
	0	32	0.014	0.011	0.008	0.005	0.003	0.000	-0.003	-0.005	-0.008	-0.011	-0.014
	10	50	0.016	0.014	0.011	0.008	0.005	0.003	0.000	-0.003	-0.005	-0.008	-0.011
	20	68	0.019	0.016	0.014	0.011	0.008	0.005	0.003	0.000	-0.003	-0.005	-0.008
	30	86	0.022	0.019	0.016	0.014	0.011	0.008	0.005	0.003	0.000	-0.003	-0.005
	40	104	0.024	0.022	0.019	0.016	0.014	0.011	0.008	0.005	0.003	0.000	-0.003
	50	122	0.027	0.024	0.022	0.019	0.016	0.014	0.011	0.008	0.005	0.003	0.000

TABLE 2 - METRIC

		AVERAGE TEMPERATURE AT TIME OF CUTTING & INSTALLATION											
°C		-50	-40	-30	-20	-10	0	10	20	30	40	50	
°F		-58	-40	-22	-4	14	32	50	68	86	104	122	
MIN/MAX POST CONSTRUCTION TEMP.	°C	°F	EXPANSION OR CONTRACTION (MM/METER)										
	-50	-58	0.000	-0.230	-0.460	-0.690	-0.920	-1.150	-1.380	-1.610	-1.840	-2.070	-2.300
	-40	-40	0.230	0.000	-0.230	-0.460	-0.690	-0.920	-1.150	-1.380	-1.610	-1.840	-2.070
	-30	-22	0.460	0.230	0.000	-0.230	-0.460	-0.690	-0.920	-1.150	-1.380	-1.610	-1.840
	-20	-4	0.690	0.460	0.230	0.000	-0.230	-0.460	-0.690	-0.920	-1.150	-1.380	-1.610
	-10	14	0.920	0.690	0.460	0.230	0.000	-0.230	-0.460	-0.690	-0.920	-1.150	-1.380
	0	32	1.150	0.920	0.690	0.460	0.230	0.000	-0.230	-0.460	-0.690	-0.920	-1.150
	10	50	1.380	1.150	0.920	0.690	0.460	0.230	0.000	-0.230	-0.460	-0.690	-0.920
	20	68	1.610	1.380	1.150	0.920	0.690	0.460	0.230	0.000	-0.230	-0.460	-0.690
	30	86	1.840	1.610	1.380	1.150	0.920	0.690	0.460	0.230	0.000	-0.230	-0.460
	40	104	2.070	1.840	1.610	1.380	1.150	0.920	0.690	0.460	0.230	0.000	-0.230
	50	122	2.300	2.070	1.840	1.610	1.380	1.150	0.920	0.690	0.460	0.230	0.000

**TABLE 3**

4" PLANKS		PSF (Factored / Ultimate)												
		20	30	40	50	60	70	80	90	100	110	121		
QUICK-SCREEN CLIP SPACING (IN) <sup>1, 2, 3</sup>	16"	Wood												
		16ga												
		18ga												
		20ga												
	24"	Wood												
		16ga												
		18ga												
		20ga												
	32"	Wood												
		16ga												
		18ga												
		20ga												

All testing has been performed using L/180 deflection limits

Substrate Types: Sheathed Wood-Frame Wall w/2.0 in. Ig. #8 Pan-head wood screws  
 Sheathed 16ga, 50ksi Steel Stud Wall w/#8 Pan-Head Self-Drilling Screws  
 Sheathed 18ga, 33ksi Steel Stud Wall w/#8 Pan-Head Self-Drilling Screws  
 Sheathed 20ga, 33ksi Steel Stud Wall w/#8 Pan-Head Self-Drilling Screws

1\_Spacing is from clip center to center  
 2\_An unfactored dead load of 1.5 psf was assumed for the cladding  
 3\_If fastening to every second stud, the attachment stud shall be staggered between adjacent runs of cladding

**TABLE 4**

6" PLANKS		PSF (Factored / Ultimate)												
		20	30	40	50	60	70	80	90	100	110	121		
QUICK-SCREEN CLIP SPACING (IN) <sup>1, 2, 3</sup>	16"	Wood												
		16ga												
		18ga												
		20ga												
	24"	Wood												
		16ga												
		18ga												
		20ga												
	32"	Wood												
		16ga												
		18ga												
		20ga												

All testing has been performed using L/180 deflection limits

Substrate Types: Sheathed Wood-Frame Wall w/2.0 in. Ig. #8 Pan-head wood screws  
 Sheathed 16ga, 50ksi Steel Stud Wall w/#8 Pan-Head Self-Drilling Screws  
 Sheathed 18ga, 33ksi Steel Stud Wall w/#8 Pan-Head Self-Drilling Screws  
 Sheathed 20ga, 33ksi Steel Stud Wall w/#8 Pan-Head Self-Drilling Screws

1\_Spacing is from clip center to center  
 2\_An unfactored dead load of 1.5 psf was assumed for the cladding  
 3\_If fastening to every second stud, the attachment stud shall be staggered between adjacent runs of cladding

## Proper Handling of Longboard Products



To help avoid injury and product damage, Longboard products require proper handling to and from storage areas during installation. When carrying or installing any products it is recommended that they be moved or carried by at least two people with each support point approximately 4ft from the ends. **Carrying products without proper support can cause excessive bending which may damage the appearance or finish of the product.** Any short cut lengths should also be carried on edge while supporting the material. See below for details.

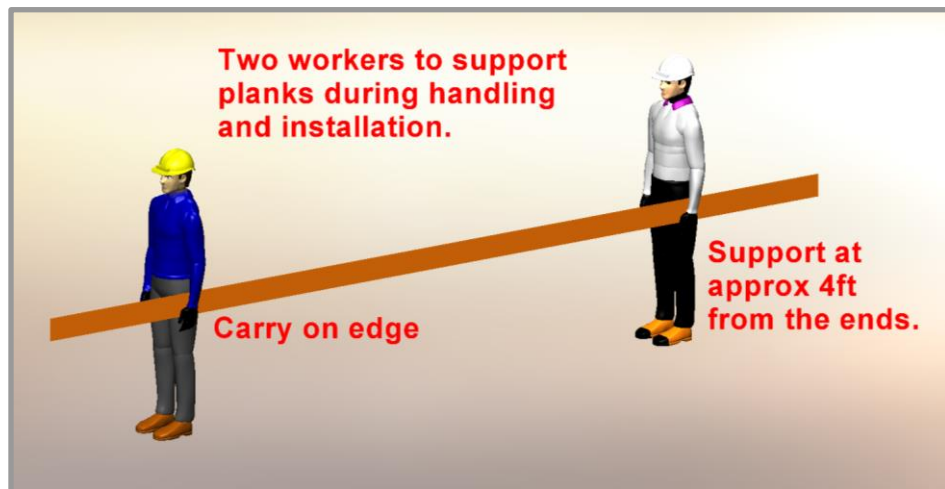
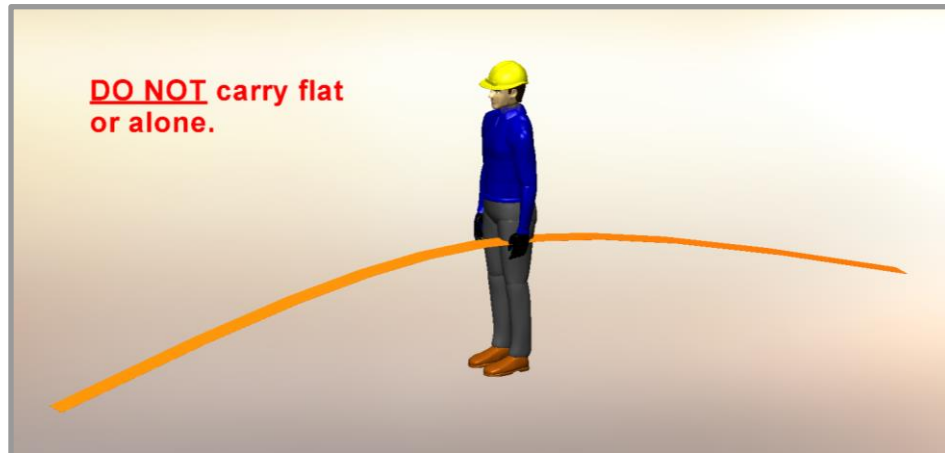

### ⚠️ Delivery, Storage & Handling ⚠️

- Always inspect the delivery for damage and contact LB ASAP if there are any issues: [info@longboardproducts.com](mailto:info@longboardproducts.com) or 1-800-604-0343 and include your PO# and any pictures if possible. Longboard is not responsible for the installation of blemished or damaged material.
- Be sure to store the material flat, keep it dry, safe & secure and remain in unopened cartons until ready to be installed.
- Always wear appropriate PPE when handling products.



Longboard Architectural Products Inc.  
© Longboard Architectural Products Inc. All rights reserved.

Longboard® is a registered trademark of Longboard Architectural Products Inc.

Longboard  
1777 Clearbrook Road  
Abbotsford, BC V2T 8X8  
Canada  
[longboardproducts.com](http://longboardproducts.com)

Every effort has been made to ensure that the information in these installation guidelines is accurate. Longboard is not responsible for printing or clerical errors.

For more information, contact client care at [info@longboardproducts.com](mailto:info@longboardproducts.com) or call toll free 1-800-604-0343.