



LONGBOARD®
INSPIRING ARCHITECTURE



Panelboard™ Soffit

Installation Guidelines

Table of Contents

Material Specifications	3
Finishes	3
Expansion and contraction	3
Material ordering and deliveries	3
Storage and handling	3
Cleaning	4
Warranty	4
Graffiti Removal	4
Components	5
Components (Typical)	5
Tools/Cutting/Fastening	6
Tools	6
Cutting	6
Fastening	7
Fastener types	7
Framing/Furring requirements	7
Fastening options onto exterior insulation	8
System Install	9
Perimeter and field area limitations	9
Component layout	10
J-Track	10
Starter J-Track	10
U-Reveal Set	10
T&G U-Reveal	10
Termination Set	10
Install Steps	11-17
Details	18
Single Butt-Joints	18-19
Multiple Floating Butt-Joints	20
Radius Guide	21
Appendix	22
Tables - Expansion & contraction	22
Tables 3 – Fastening to Structure	23
Tables 4-6 – Fastening to Sheathing	24-26
Handling and care of products	27
Contact Info	28

Material Specifications

Finishes

- Longboard Products are available in a wide range of woodgrains and solid colors
- Custom solid colors are available upon request
- Longboard woodgrains have a repeat pattern, shipped in sets mated back-to-back in each box. Install these as they come out of the box, as an A&B pattern (need to assess onsite), staggering each plank approx. 1-2' (305-610mm) from the previous plank to achieve a random pattern aesthetic.
- Longboard Products are not recommended for use on marine applications in direct contact with salt water.

Longboard extruded products are produced 1" (25mm) oversized, as one end is drilled for the coating process, and both ends have 1/2" (12mm) of masking tape (woodgrains only) which must be cut off for best results.

Longboard Cladding is to be installed outboard of a weather resistant barrier, including all flashings, following code, and building requirements.

Expansion & Contraction

Planks & components expand & contract 1/4" (6mm) over 24' (7.3m) in all directions, measured over a 30°C (54°F) temperature range. Due to this range of movement, the following expansion components should be installed perpendicular to planks every:

-
- 24' (7.3m) max¹ Perpendicular to Planks: Traditional Flat Reveal, U-Reveal Set

¹Note: 40' (12.2m) max if using staggered butt-joints.

Other options (Perpendicular to Planks only)

-
- 12' (3.7m) -Craftsman U-Reveal Set
 - 6' 8" (2m) -Precision Flat Reveal

When using expansion components, each plank must terminate into a minimum of one (1) component to allow for expansion & contraction.

See: Appendix for tables of expansion/contraction calculations per foot/meter of material.

Material Ordering & Delivery

-
- **Packaging:** Planks are sold in box quantities:
6" Smooth: 96 SQ FT/Box (8/24's) w. 90pcs Quick-Screen Clips included
Components are sold individually by the 12' (3.7m) length.
 - **Shipping:** Most Popular Finishes -ready to ship within 1 week
Additional Finishes -ready to ship within 14 weeks
Delivered on 24' (7.3m) long skids weighing up to 2000 lbs. A mechanical lift with forks is required on site to receive the order.
 - **QC:** Always inspect the delivery for damage and contact LB ASAP if there are any issues: info@longboardproducts.com or 1-800-604-0343 and include your PO# and any pictures if possible. Mark the delivery receipt as "damaged" and accept the delivery as-is. Longboard is not responsible for the installation of blemished or damaged material.

Storage & Handling

Be sure to store the material flat, keep it dry, safe & secure and remain in unopened cartons until ready to be installed.

See Appendix for proper handling and care instructions.

Cleaning Recommendations

- Initial and periodic cleaning for best looking product
- Basic methods use a combination of moderate water pressure, soft sponge/brush and a mild detergent (Safe for your hands, safe for the product)

⚠ NEVER use aggressive acid or alkaline cleaners on Longboard finishes. Do not use cleaners containing Trisodium Phosphate, Phosphoric Acid, Hydrochloric Acid, Hydrofluoric Acid, Fluorides, or any other compound that is known to react with metal.

***See Cleaning Guide for full requirements & cleaning schedule:**

longboardproducts/resources/care-maintenance.com

Warranty

Upon substantial completion of the project, register for warranty online here: longboardproducts.com/warranty

⚠ Registration is required for the warranty to be in effect.

Graffiti Removal

Standard Woodgrain

Use Standard soap & water only

D2000 Solid Color

	Prosoco Cleaner	MEK Solvent	
Permanent Marker	<input checked="" type="checkbox"/>	<input checked="" type="checkbox"/>	 MEK Solvent Prosoco Anti-Graffiti Cleaner
Oil Based Spray Paint	<input checked="" type="checkbox"/>	<input checked="" type="checkbox"/>	
Water Based Spray Paint	<input checked="" type="checkbox"/>	<input checked="" type="checkbox"/>	
Adhesive Tape	<input checked="" type="checkbox"/>	<input checked="" type="checkbox"/>	

SPECIAL ORDER - EXT. LEAD TIMES CONTACT LB

Anti-Graffiti High Gloss Woodgrain

	MEK Solvent	
Permanent Marker	<input checked="" type="checkbox"/>	 MEK Solvent
Oil Based Spray Paint	<input checked="" type="checkbox"/>	
Water Based Spray Paint	<input checked="" type="checkbox"/>	
Adhesive Tape	<input checked="" type="checkbox"/>	

Note: Cleaning the surface with a cleanser that is not diluted as per instructions, may result in damage to the coating.

Components

Components (Typical)

The Panelboard™ system consists of components used in conjunction with each other to create a panelized look. For all LB components go to longboardproducts.com.

V-Groove Planks

* 48 sq. ft. box quantities † 96 sq. ft. box quantities

Size	12' *	24' *	12' Perf *	24' Perf *
2½"	3V.145	-	3VP.145	-
4"	4V.145	4V.289	-	-
6"	6V.145	6V.289	6VP.145	6VP.289



Butt-Joint Fastening Kit

Smooth Planks

Size	12' *	24' *	12' Perf *	24' Perf *
6"	6PSP.145	6PSP.289	6PSP.145	6PSP.289



Quick-Screen Clip

Channel Planks

Size	12' *	24' *
6"	6CH.145	6CH.289

Accessories

Product	Qty	SKU
Quick Screen Clips	1750, box	CLIP.N1750
Quick Screen Clips	100, bag	CLIP.N100
1/16" U-SHM	250, bag	SHIM.1001
Butt-Joint Fastening Kit (6")	20 kits, bag	TGBJKIT
Touch Up Pens <i>Reach out to confirm color with account manager.</i>	N/A	TUP

Trim Components

Type	Style	Product	Dimensions	SKU
Starter	Precision	Starter J-Track	(5/8") - 12'	1SJT.145
Starter	Traditional	Starter Strip	(1-7/8") - 12'	2SS.145
Starter	Traditional	Back-to-Back Starter Strip	(1-1/4")	2BTSS.145
J-Track	Precision	Two Piece J-Track	(5/8") - 12'	1X1JT.145
J-Track	Precision	J-Track	(5/8") - 12'	1JT.145
J-Track	Craftsman	J-Track	(7/8") - 12'	JT23.145
J-Track	Craftsman	Two Piece J-Track	(7/8") - 12'	JT23S.145
J-Track	Traditional	Two Piece J-Track	(1-3/8") - 12'	1X2JT.145
Corner	Precision	Outside Corner	(3/16") - 12'	05OC.145
Corner	Craftsman	Inside Corner	(3/4") - 12'	1IC.145
Corner	Craftsman	Outside Corner	(1") - 12'	1OC.145
Corner	Traditional	Corner Set	(2") - 12'	2CORS.145
Corner	Traditional	3" Smooth	(3") - 24'	3SCP.289
Corner	Traditional	3" V-Groove	(3") - 24'	3SVP.289
Reveal	Precision	Flat Reveal	(1/2") - 12'	1FR.145
Reveal	Precision	T&G Flat Reveal	(1/2") - 24'	1TGR.289
Reveal	Craftsman	U-Reveal Set	(3/4") - 12'	1URS.145
Reveal	Craftsman	T&G U-Reveal	(3/4) - 24'	1TGURK.289
Reveal	Traditional	U-Reveal Set	(1-1/2") - 12'	2URS.145
Reveal	Traditional	Flat Reveal Set	(1-1/2") - 12'	2FRS.145
Reveal	Traditional	T&G U-Reveal	(1 1/2") - 24'	2TGURK.289
Reveal	Traditional	Offset Flat Reveal Set, J-Track Base	(2") - 12'	2OFFJ.145
Reveal	Traditional	Offset Flat Reveal Set, Termination Base	(2") - 12'	2OFFT.145
Termination	Precision	Termination Set	(5/8") - 12'	1TS.145
Termination	Craftsman	Termination Set	(7/8") - 12'	TS23S.145
Termination	Traditional	Termination Set	(1-3/8") - 12'	2TS.145
Compression Joints	Traditional	Compression Joint	(1-3/8") - 24'	2CJ.289



V-Groove Planks Channel Planks Smooth Planks Perforated Planks



Precision Starter J-Track Traditional Starter Strip Traditional Back-to-Back Starter Strip Precision Two-Piece J-Track



Precision J-Track Craftsman J-Track Craftsman Two Piece J-Track Traditional Two Piece J-Track

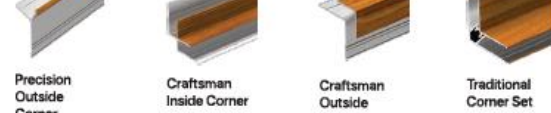

Precision Outside Corner Craftsman Inside Corner Craftsman Outside Corner Traditional Corner Set



Traditional 3" Smooth Corner Traditional 3" V Groove Corner Precision Flat Reveal Precision T&G Flat Reveal



Craftsman U-Reveal Set Craftsman T&G U-Reveal Traditional U-Reveal Set Traditional Flat Reveal Set



Traditional T&G U-Reveal Traditional Offset Flat Reveal Set, J-Track Base Traditional Offset Flat Reveal Set, Termination Base Precision Termination Set







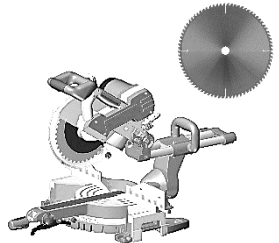

Craftsman Termination Set Traditional Termination Set Traditional Compression Joint

Tools/Cutting/Fastening

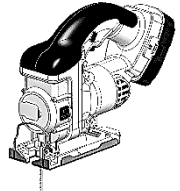
Tools

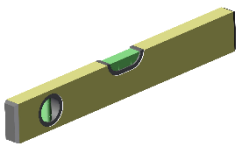
Commonly used tools for Panelboard Soffit install.

			
Table Saw with Carbide Metal Blade Non-ferrous 60-80T (for cutting aluminum)	Miter Saw with Carbide Metal Blade Non-ferrous 60-80T (for cutting aluminum)	Cordless Drill with clutch	Jig Saw (for protrusions)
			
Rubber Mallet (or Hammer)	Level	Hole Saw (for lighting fixtures)	#10 Pan Head Screws <small>*Length, thread and point to suit substrate</small>

Cutting

⚠ Always be sure to wear appropriate PPE: eye & hearing protection.

Cut planks using a Miter Saw and Table Saw, always allowing for expansion & contraction. Trim the taped/drilled ends of all stock length material by at least **1/2" (12mm) each end** and discard.

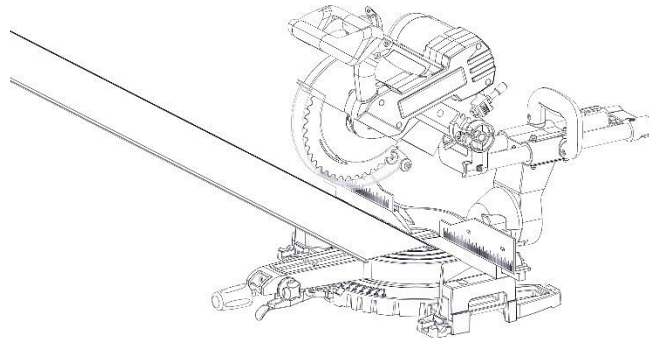

Fastening

⚠ Always consult the project engineer, architect or authority having jurisdiction to understand the project specific fastening requirements.

Typical spacing:
-using **#10 Fasteners**

- Trim components including Starter Strip
- **16" (406mm) O.C.**
 - **24" (610mm) O.C. (for direct to truss)**

Planks
Standard wind loads

- **32" (813mm) O.C.**

Higher wind loads

- **16" (406mm) O.C.**

See **Appendix for fastening specs: Tables 3-6**

Framing/Furring requirements

Always consult the local building authority and follow local building code requirements. When attaching to **Hitch Cladding attachment System** refer to Hitch Install Guide for requirements.

See **Appendix for framing/furring/sheathing specs: Tables 3-6**

Fastener types

RECOMMENDED

Pan-Head



*Length, thread and point to suit substrate

CORRECT

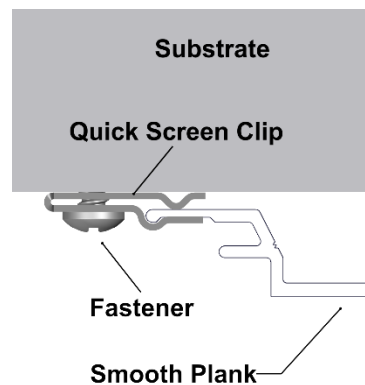

DO NOT USE

Flat-Head

Oval-Head

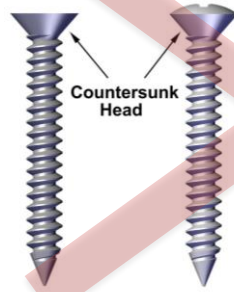

INCORRECT

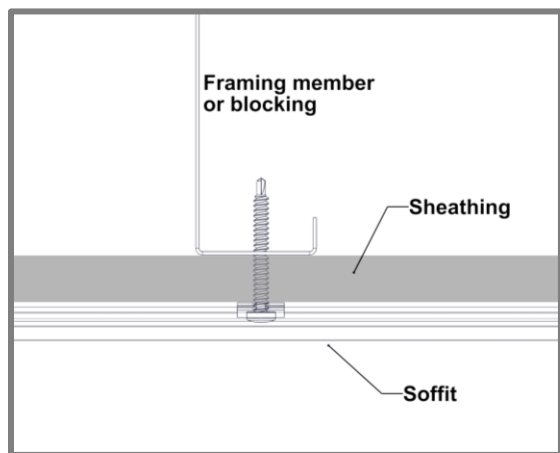
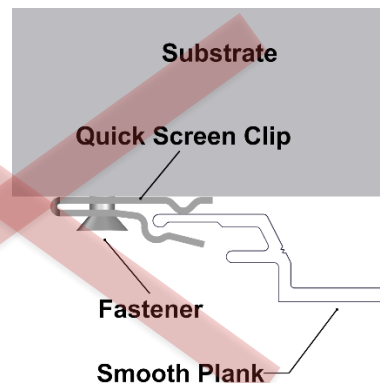

Fastening to Structure
(see Table 3 for specs)

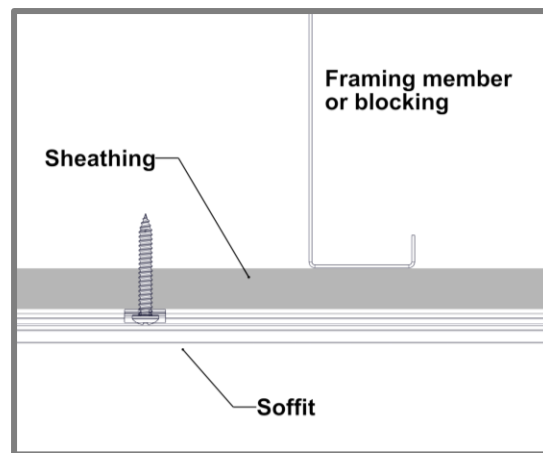

Fastening to Sheathing
(see Tables 4-6 for specs)

Fastening options onto exterior insulation

*Never direct to insulation. Must be secured directly to solid secure substrate.

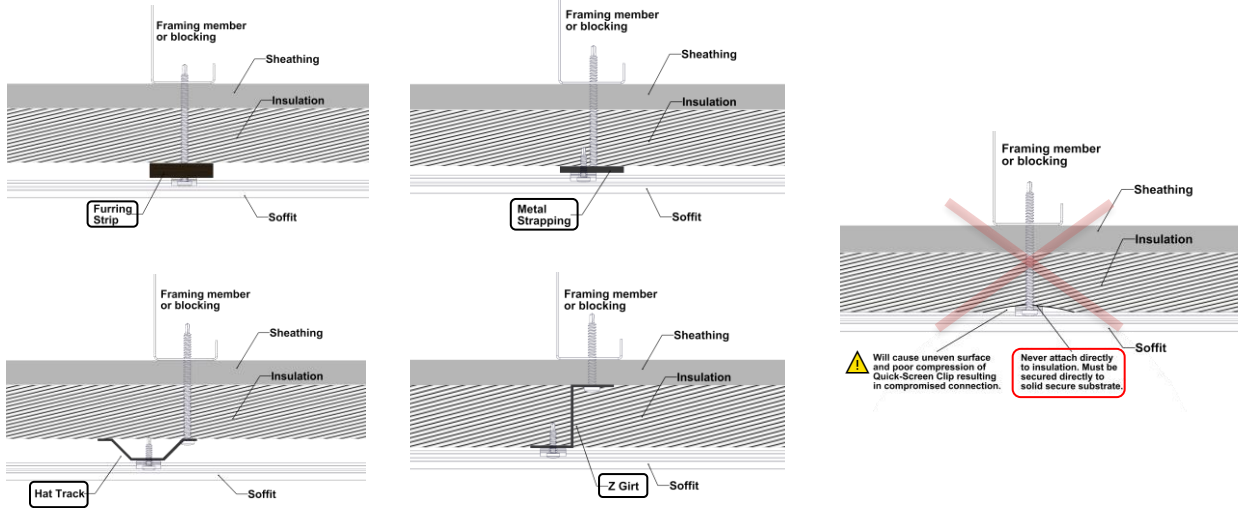

System Install

Perimeter and field area limitations

- Measure and layout your wall area to consider plank & component alignment with fixtures, penetrations, and adjacent walls and edges, for desired appearance. Consider using butt-joints along runs to minimize waste.
- Longboard system typical dimensions:

Planks width	- 6" (152mm)
Planks depth	- 1/2" (12mm)
Planks and Quick-Screen Clips depth	- 9/16" (14mm)
Trim Components depth	- 5/8" (15mm)

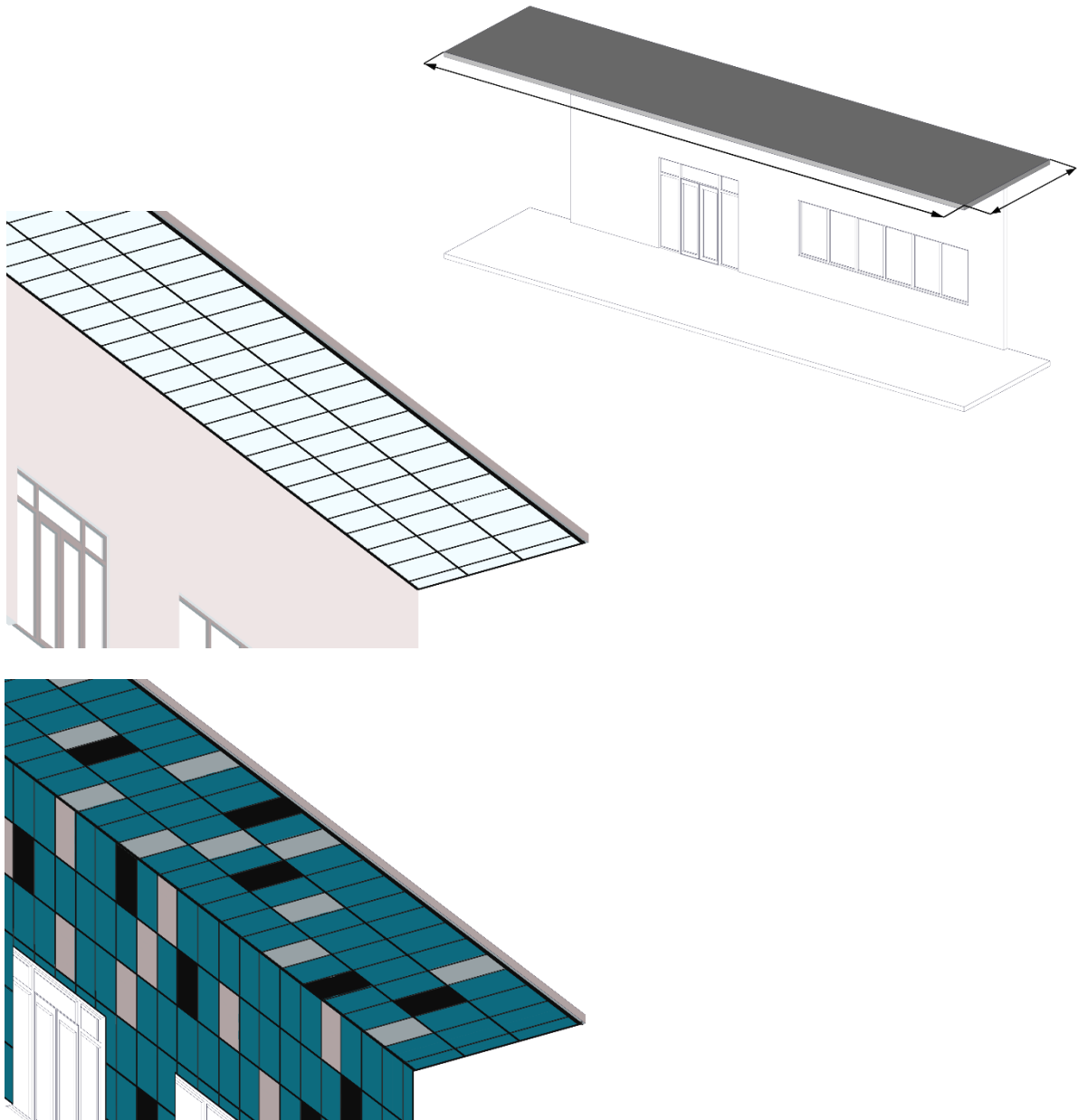

Component layout

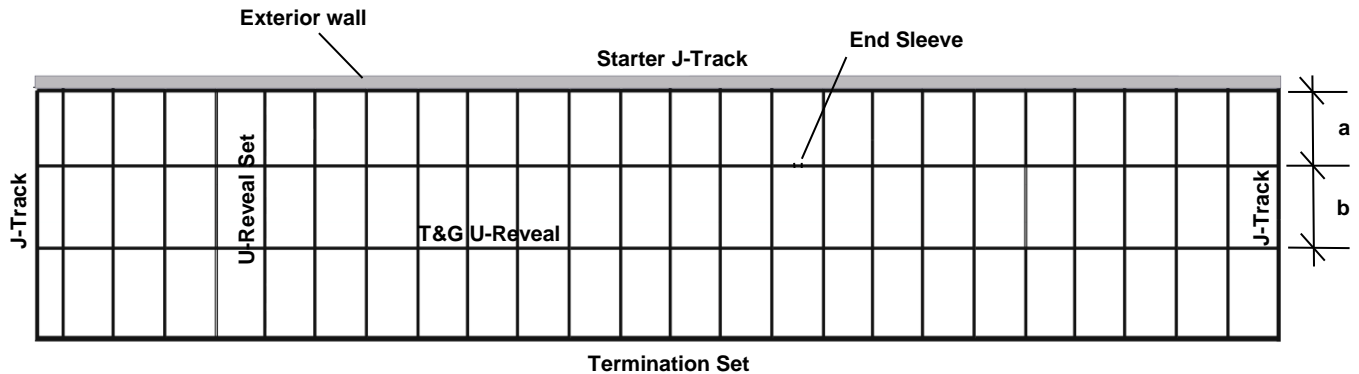

Measurement considerations:

1 1/2" (38mm) T&G U-Reveal (up to 24' length panels)

- (a) Start to Panel - Measuring from outer edge of the Starter J-Track to the center of the 1 1/2" U-Reveal, add 5/8" (16mm) to the dimension of the Plank area. = $6"(X) + 5/8"$ to ϕ
- (b) Panel to Panel - Measuring from center to center of the 1 1/2" U-Reveal, add 1" (25mm) to the dimension of the Plank area. = $6"(X) + 1"$ to ϕ

3/4" (19mm) T&G U-Reveal (up to 12' length panels)

- (a) Start to Panel - Measuring from outer edge of the Starter J-Track to the center of the 3/4" U-Reveal, add 1/4" (6mm) to the dimension of the Plank area. = $6"(X) + 1/4"$ to ϕ
- (b) Panel to Panel - Measuring from center to center of the 3/4" U-Reveal, add 3/8" (10mm) to the dimension of the Plank area. = $6"(X) + 3/8"$ to ϕ

COMPONENTS -12' Stock lengths unless otherwise noted

J-Track 5/8", Two Piece J-Track (5/8, 7/8", 1 3/8")

Location: Perpendicular to Planks (eg: sides of soffit areas), or around penetrations or cutouts.
 Details: Notch the flange at the ends where they meet corner components.

Starter J-Track 5/8", Starter Strip

Location: Where starting with a full width Plank, typically along the bottom of the installation for horizontal Planks.
 Details: Alternatively, Back-to Back Starter can be used at the center of each soffit area for equal width ends.

U-Reveal Set (3/4", 1 1/2")

Location: Perpendicular to Planks, used to set panelized widths.
 Details: Two-piece component (cap & base).

T&G U-Reveal (3/4", 1 1/2")

Location: Parallel to Planks, used to set panelized lengths.
 Details: Single-piece component, use End Sleeve (included) every 24' max. (24' Stock lengths)

Termination Set (5/8", 7/8", 1 3/8")

Location: Parallel to Planks along finish side of the installation area and other penetrations.
 Details: Install base only to start and cap after planks are installed.

Install steps

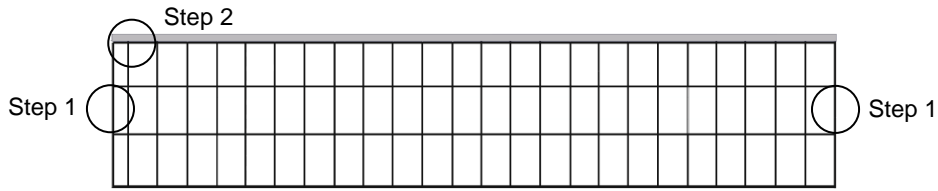

Step 1 - J-Track

Install J-Track or Two-Piece J-Track perpendicular to Planks (eg: sides of soffit areas), or around penetrations or cutouts. Fasten every 16" O.C. with #10 Pan Head Screws. Trims can be mitered for a clean corner look.

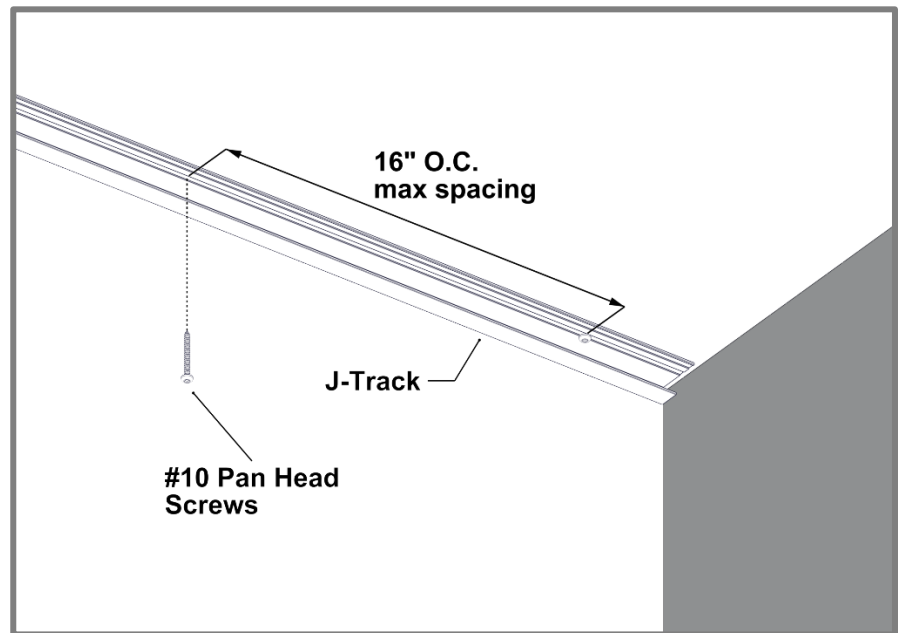

Step 2 - Starter J-Track

Install Starter J-Track or Starter Strip along the edge of the soffit(s), fastening every 16" O.C. with #10 Pan Head Screws. Notch the Starter J-Track to suit the trim component.

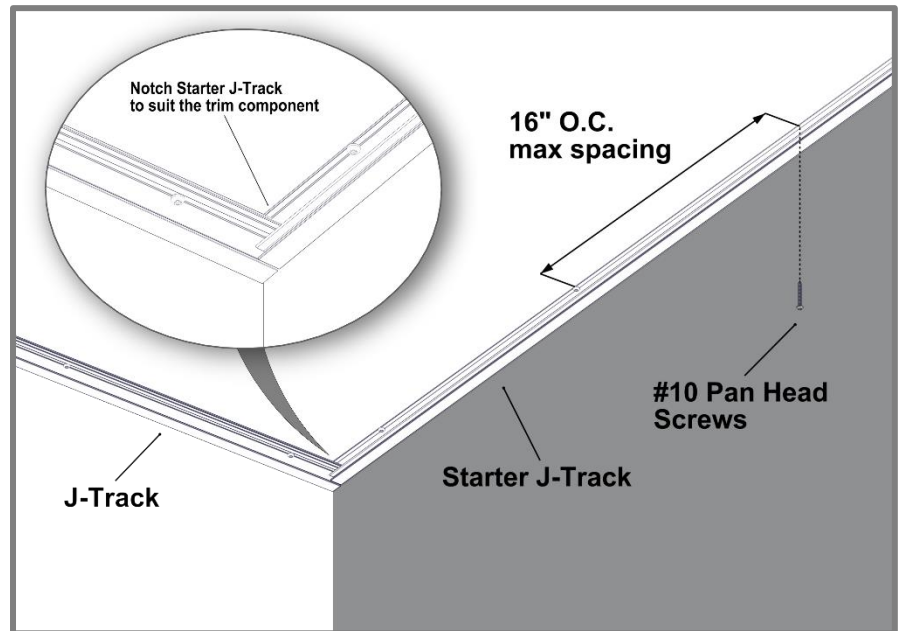

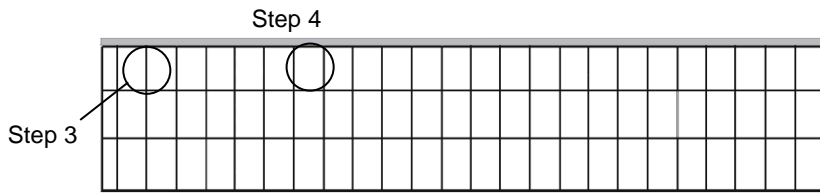

Step 3 - U-Reveal

Install U-Reveal Set (base only) at the desired panelized length, fastening every 16" O.C. with #10 Pan Head Screws.

⚠ PLANK PREPARATION DURING INSTALL

1. **No** Taped/Drilled ends (cut off 1/2" each end).
2. **No** Damage/dents and correct plank sequence per project.
3. **Confirm** allowance for expansion/contraction & confirm trim/caps cover.

Step 4 - Planks

Place the planks into the groove of the Starter J-Track, engaging the tongue. It is good practice to check your installation every 2-3 rows for level or plumb and flat or straight, for best results.

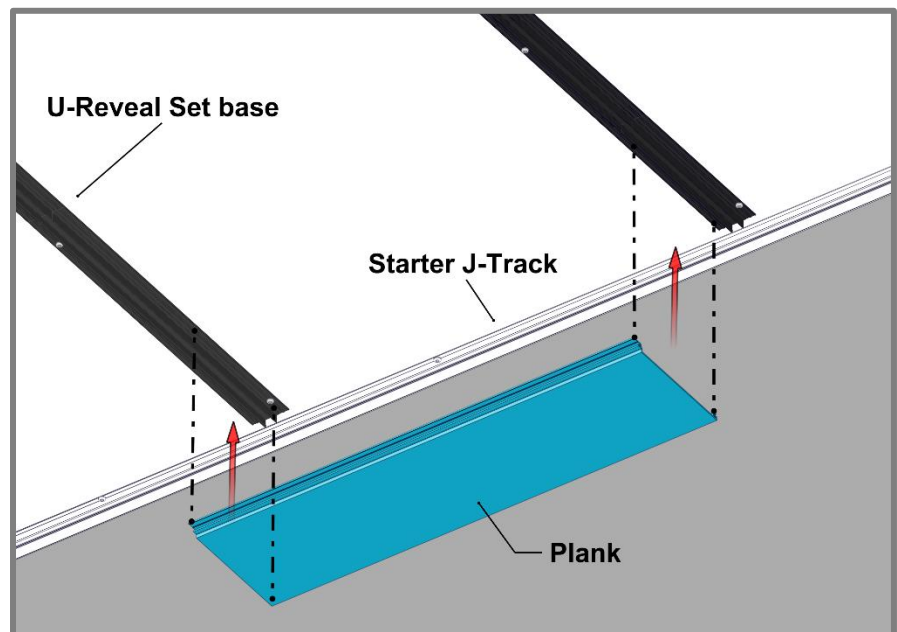
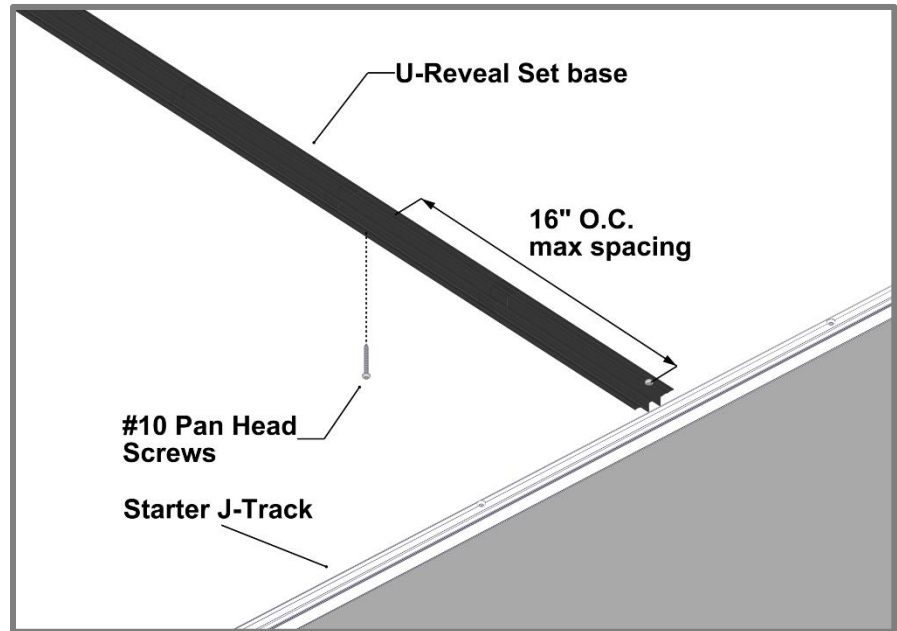

Ensure there is sufficient room for expansion and contraction of each Plank, also confirming component caps will cover.

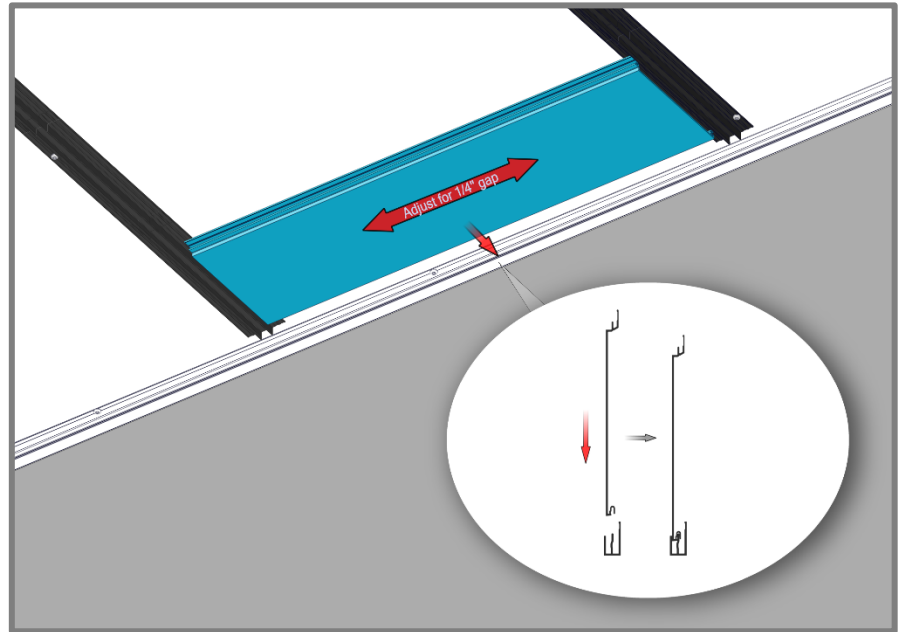

Install Quick Screen Clips every 32" (813mm) O.C. max spacing. Hard fasten only one point near the center of each plank or fasten at the butt-joints where butt-joints are used. Shim Quick-Screen Clips where needed to correct any substrate inconsistencies.

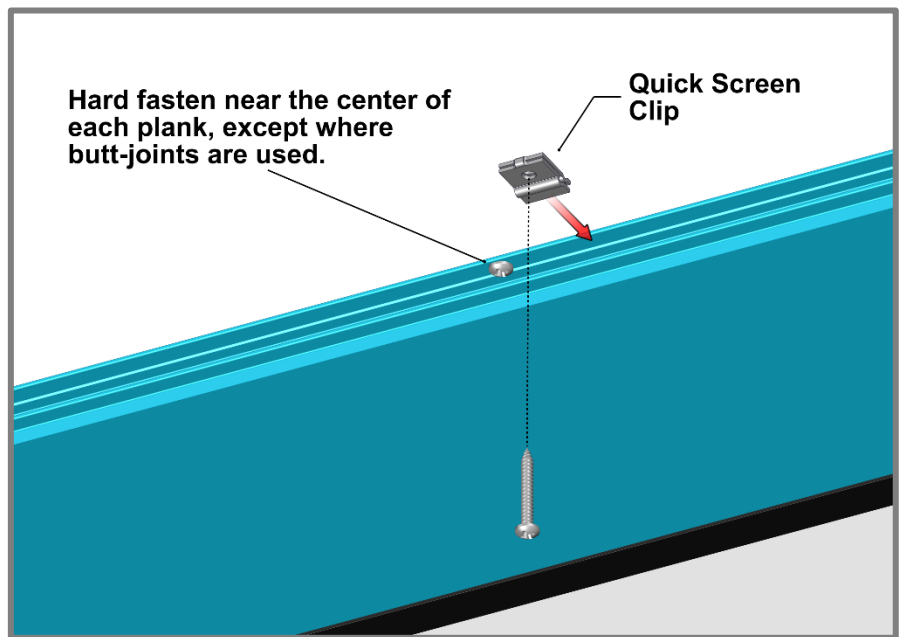

Where anchoring the planks securely can only be achieved over component flanges; split the Quick Screen Clip and use one piece on the front. This will maintain each Planks ability to expand and contract.

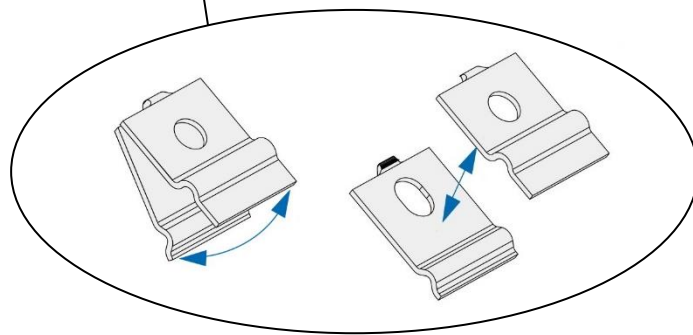
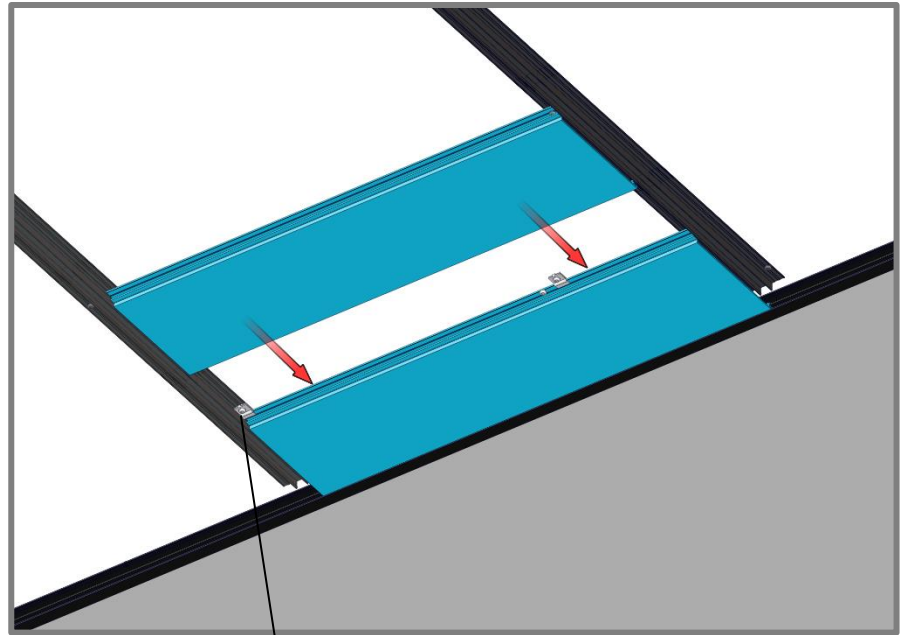

Step 5

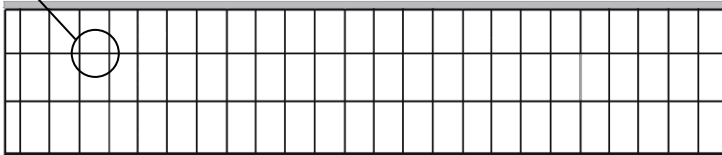

Step 5 - T&G U-Reveal

Install T&G U-Reveal at the Panelized width locking it into the tongue of the Planks.

⚠ Do Not use fasteners or Quick-Screen Clips on Planks which engage with the groove side of the T&G U-Reveal.

Fasten T&G U-Reveal with Quick Screen Clips and fasteners every 32" O.C. Hard fasten near the center of each T&G U-Reveal length. Where using multiple lengths of T&G U-Reveal, leave a 1/4" gap between butt-joints for thermal movement.

- Where using the Craftsman T&G U-Reveal (3/4"), install the included Craftsman End Sleeve to cover the 1/4" butt-joints. Use a small amount of structural silicone on a single side of the End Sleeve, leaving the opposite side dry and free to expand and contract.
- Where using the Traditional T&G U-Reveal (1-1/2"), install the included Traditional End Sleeve to cover the opposite side, free to expand and contract.

Step 6 – Next sections

Repeat install steps 3-5.

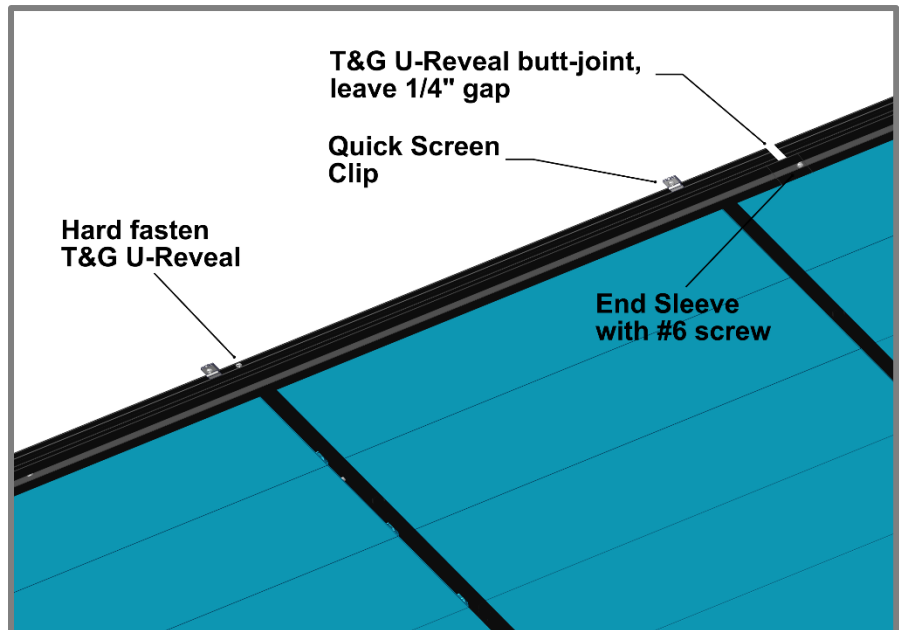
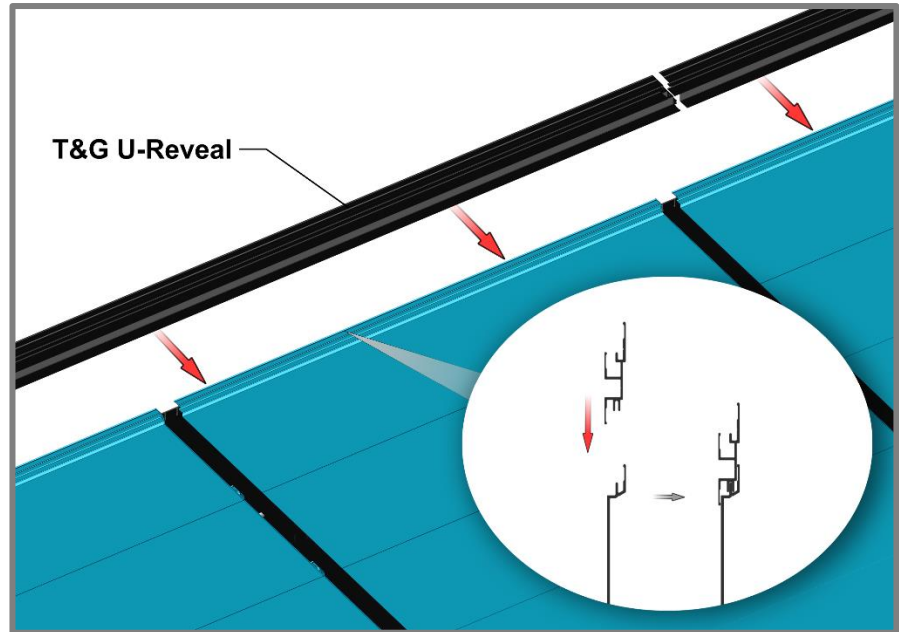

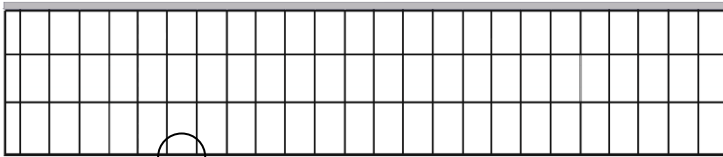

Step 7,8

Step 7 – Termination Set

Install Termination Set (base only), fastening every 16" O.C.

Where terminating cut planks, provide a positive stop approximately every 16" (406mm).

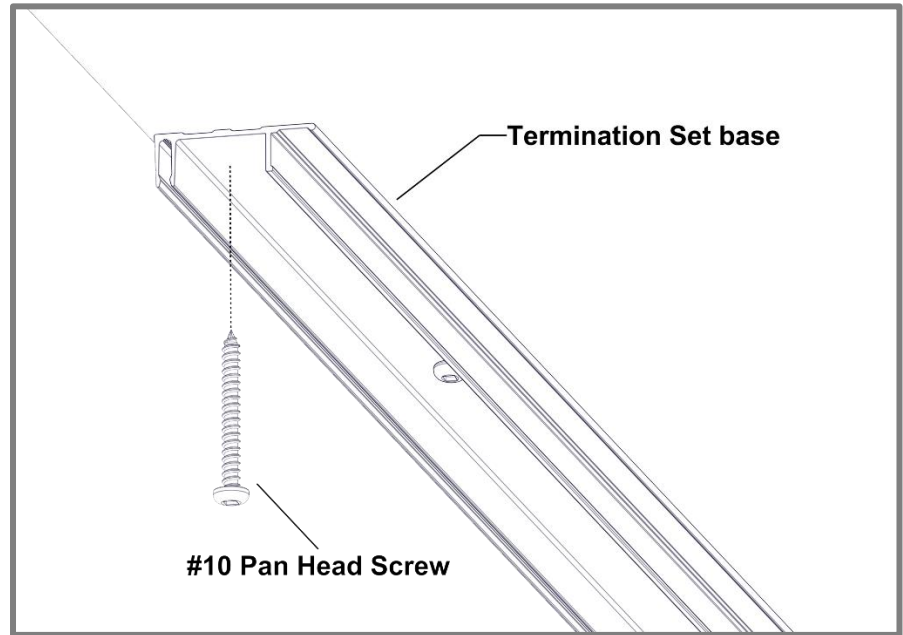

Step 8 – Last Row of Planks

Rip the last Plank, cutting it to width to suit the installation area(s). Install edge plank with a 1/4" gap and screw to lock the plank into place.

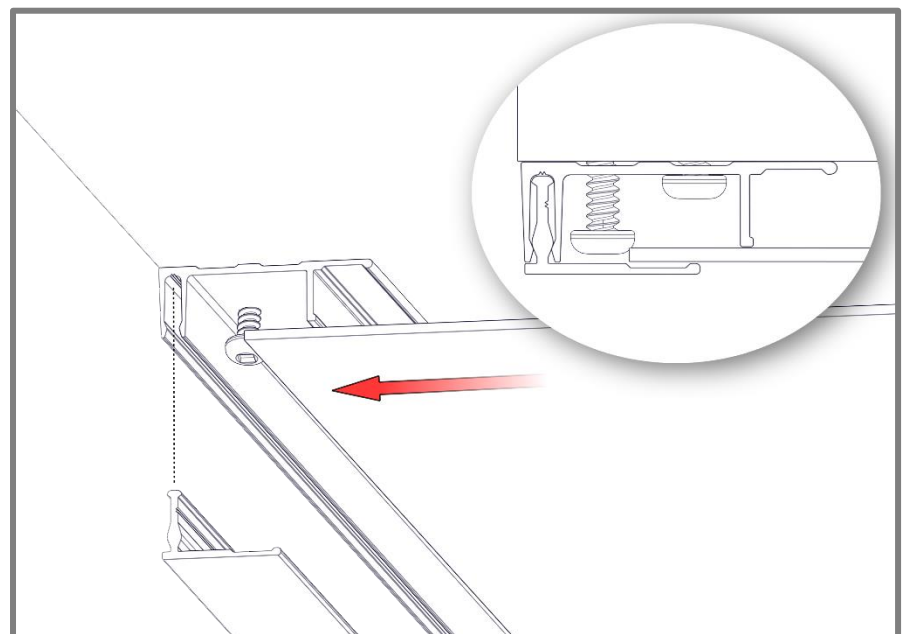

Step 9 - Once planks are installed, finish off the perimeter trims with caps from two-piece sets.

Component Caps

Location: Installed onto the base of the two-piece sets.

Details: If required, use a rubber mallet or hammer and block to protect the finish during this process.

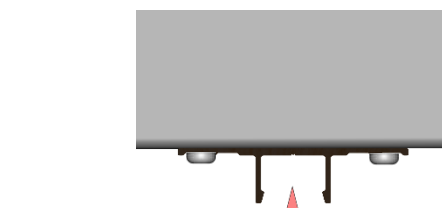

U-Reveal Set Cap

Trim sizes:
3/4", 1-1/2"

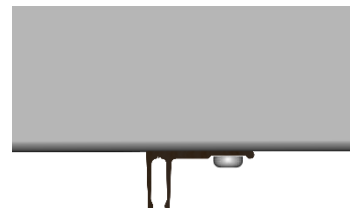

Two-Piece J-Track Cap

Trim sizes:
5/8", 7/8", 1-3/8"

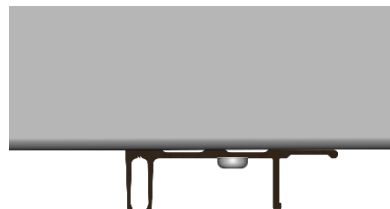

Termination Set Cap

Trim sizes:
5/8", 7/8", 1-3/8"



Details

Single Butt-Joints

- Consider using butt-joints along runs to minimize waste.
-  When installing staggered butt-joints, use the Butt-Joint Fastening Kit to ensure joints do not open up **(See Detail A)**
Fasteners should be placed at the uppermost location of the plank flange, to not interfere with the next plank engaging the tongue and groove properly. At the butt-joint, fasteners should be anchored into the Butt-Joint backer plate.
- **(See Detail B)**
- Rivets can be used for single butt-joints, however clearance of the rivets and room for movement is required.
- On exposed cuts such as butt-joints, trim ends or similar, use touch-up paint pens (purchased separately) to finish the ends of the two (2) planks at the butt-joint.
- DO NOT hard-fasten a plank to a component trim, as this will restrict its ability to expand & contract into the component.
- If no butt joints along the length, it is good practice to hard-fasten each plank directly through the flange near the center, to keep the planks from migrating.
- DO NOT hard-fasten more than one (1) location per plank.
- Hard fasten at the butt-joint or the center of each plank run.

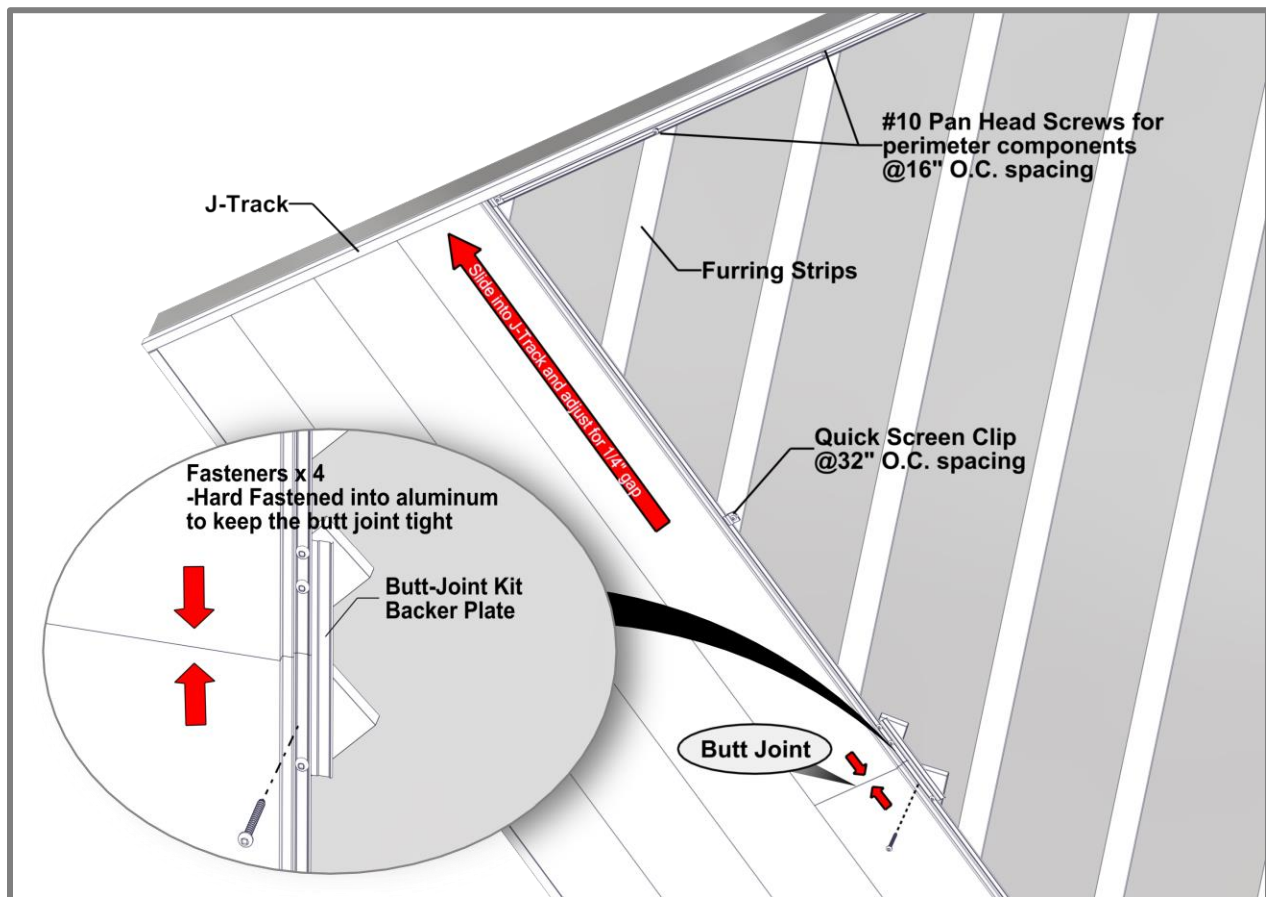

Detail A

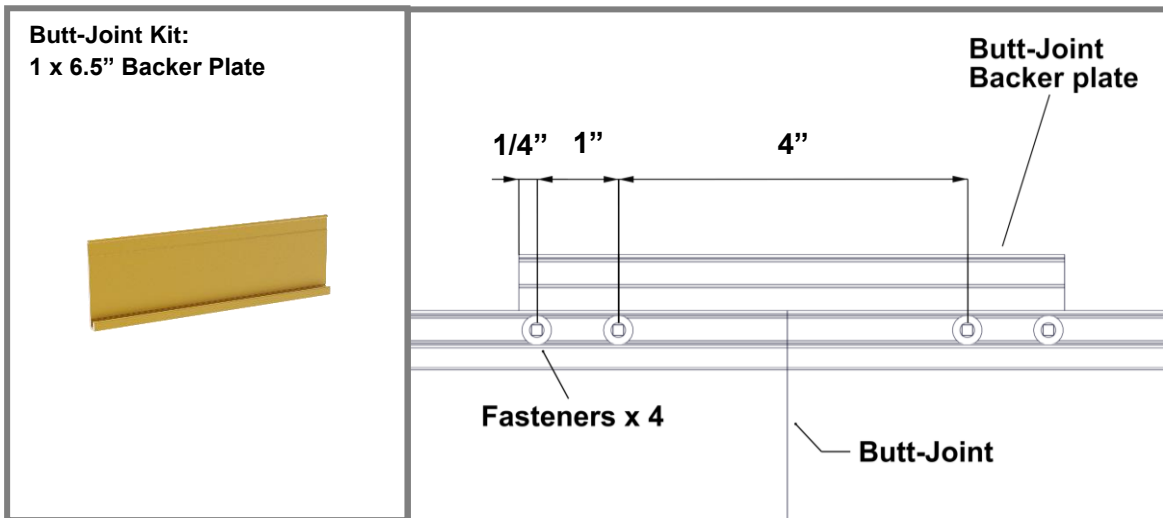

Detail B -Backer Plate (Hard Fastened)

Multiple Floating Butt-Joints

- ⚠ When installing staggered multiple floating butt-joints, use the Butt-Joint Fastening Kit to ensure joints do not open up. Rivets should be placed at the center of the plank flange, to not interfere with the next plank engaging the tongue and groove properly. **(See Detail C)**
- MUST HAVE furring strips or girts to allow room for movement.
- Recommended to be installed between furring strips or framing members to avoid contact which would restrict movement. **(See Detail D)**
- On exposed cuts such as butt-joints, trim ends or similar, use touch-up paint pens (purchased separately) to finish the ends of the two (2) planks at the butt-joint.
- DO NOT hard-fasten a plank to a component trim, as this will restrict its ability to expand & contract into the component.
- DO NOT hard-fasten more than one (1) location per multiple plank run.
- Hard fasten near the center of the multiple plank run.

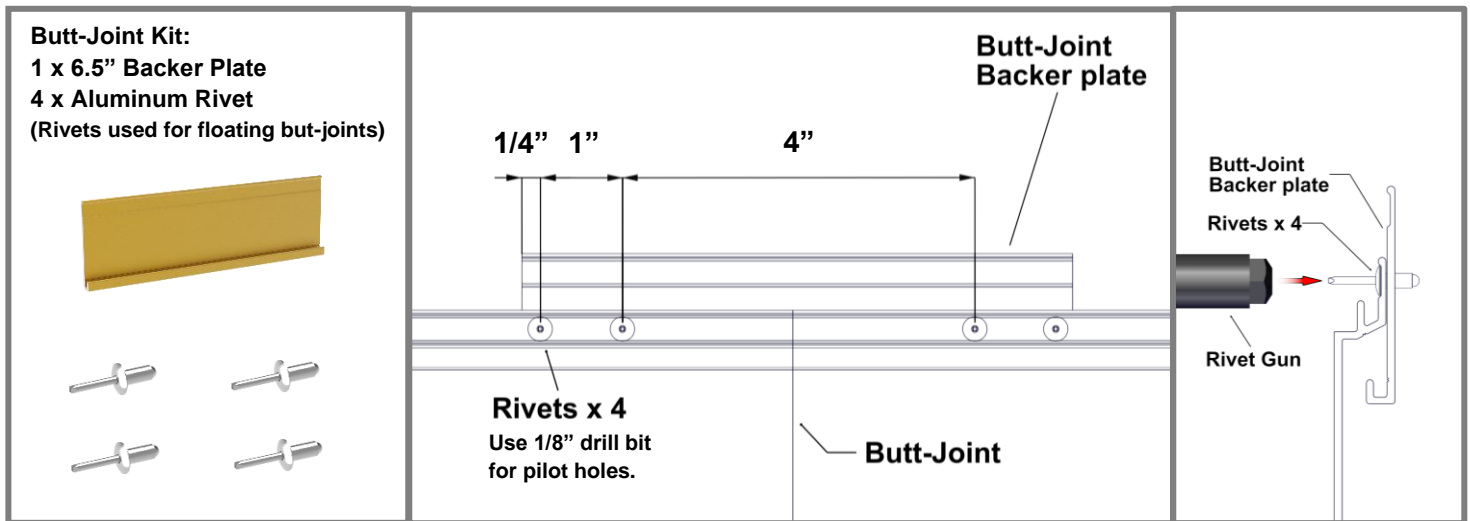

Detail C -Floating Butt-Joint

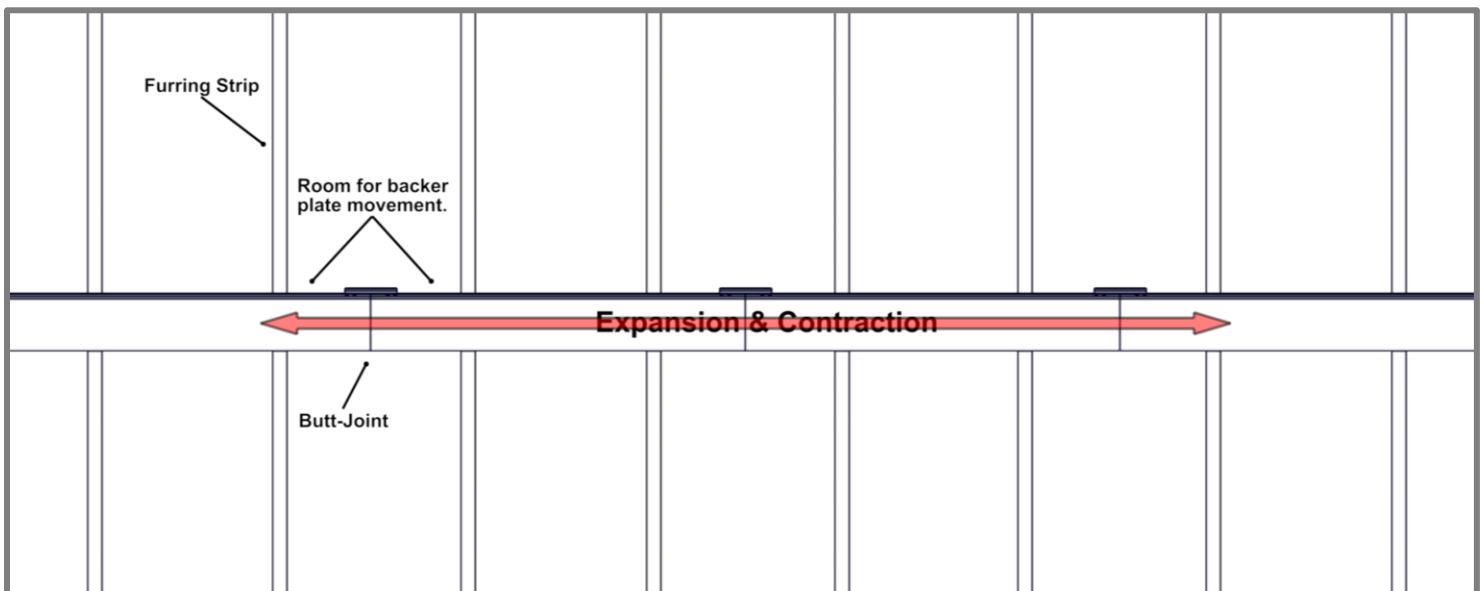

Detail D -Butt-Joint Movement

Radius Guide for Trims & Planks

Trim Description	Min. Bending Radius	Ref.
Precision J-Track (5/8")	15' (4.57m)	A
Non-Tempered Precision J-Track (5/8")	1.5' (0.46m)	B
Two-Piece J-Track (5/8")	15' (4.57m)	A

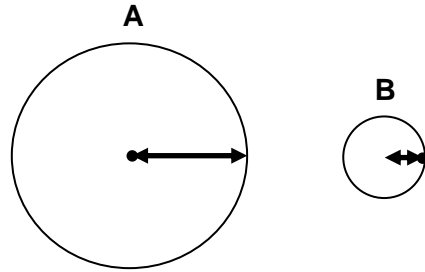

When bending & securing components, bend against solid secure object and take care not to over bend.

Plank Description	Min. Bending Radius		
	C (Concave/Convex)	D (Convex)	E (Concave)
4" V-Groove	12' (4.57m)	3' (0.91m)	6' (1.83m)
6" V-Groove	12' (4.57m)	3' (0.91m)	6' (1.83m)
6" Channel	12' (4.57m)	3' (0.91m)	6' (1.83m)

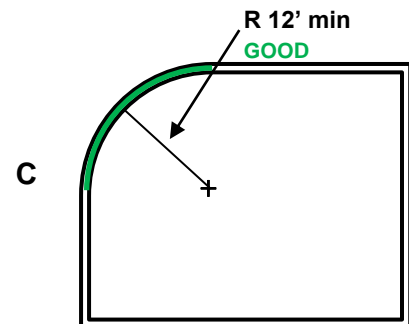
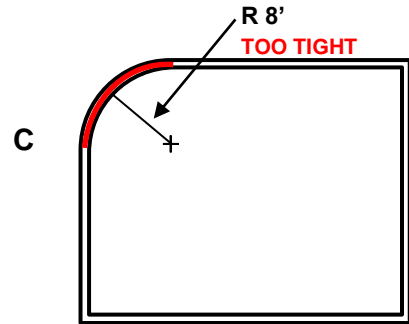

Appendix

Expansion and Contraction Tables

TABLE 1 - IMPERIAL

		AVERAGE TEMPERATURE AT TIME OF CUTTING & INSTALLATION											
°C		-50	-40	-30	-20	-10	0	10	20	30	40	50	
°F		-58	-40	-22	-4	14	32	50	68	86	104	122	
MIN/MAX POST CONSTRUCTION TEMP.	°C	°F	EXPANSION OR CONTRACTION (INCH/FOOT)										
	-50	-58	0.000	-0.003	-0.005	-0.008	-0.011	-0.014	-0.016	-0.019	-0.022	-0.024	-0.027
	-40	-40	0.003	0.000	-0.003	-0.005	-0.008	-0.011	-0.014	-0.016	-0.019	-0.022	-0.024
	-30	-22	0.005	0.003	0.000	-0.003	-0.005	-0.008	-0.011	-0.014	-0.016	-0.019	-0.022
	-20	-4	0.008	0.005	0.003	0.000	-0.003	-0.005	-0.008	-0.011	-0.014	-0.016	-0.019
	-10	14	0.011	0.008	0.005	0.003	0.000	-0.003	-0.005	-0.008	-0.011	-0.014	-0.016
	0	32	0.014	0.011	0.008	0.005	0.003	0.000	-0.003	-0.005	-0.008	-0.011	-0.014
	10	50	0.016	0.014	0.011	0.008	0.005	0.003	0.000	-0.003	-0.005	-0.008	-0.011
	20	68	0.019	0.016	0.014	0.011	0.008	0.005	0.003	0.000	-0.003	-0.005	-0.008
	30	86	0.022	0.019	0.016	0.014	0.011	0.008	0.005	0.003	0.000	-0.003	-0.005
	40	104	0.024	0.022	0.019	0.016	0.014	0.011	0.008	0.005	0.003	0.000	-0.003
	50	122	0.027	0.024	0.022	0.019	0.016	0.014	0.011	0.008	0.005	0.003	0.000

TABLE 2 - METRIC

		AVERAGE TEMPERATURE AT TIME OF CUTTING & INSTALLATION											
°C		-50	-40	-30	-20	-10	0	10	20	30	40	50	
°F		-58	-40	-22	-4	14	32	50	68	86	104	122	
MIN/MAX POST CONSTRUCTION TEMP.	°C	°F	EXPANSION OR CONTRACTION (MM/METER)										
	-50	-58	0.000	-0.230	-0.460	-0.690	-0.920	-1.150	-1.380	-1.610	-1.840	-2.070	-2.300
	-40	-40	0.230	0.000	-0.230	-0.460	-0.690	-0.920	-1.150	-1.380	-1.610	-1.840	-2.070
	-30	-22	0.460	0.230	0.000	-0.230	-0.460	-0.690	-0.920	-1.150	-1.380	-1.610	-1.840
	-20	-4	0.690	0.460	0.230	0.000	-0.230	-0.460	-0.690	-0.920	-1.150	-1.380	-1.610
	-10	14	0.920	0.690	0.460	0.230	0.000	-0.230	-0.460	-0.690	-0.920	-1.150	-1.380
	0	32	1.150	0.920	0.690	0.460	0.230	0.000	-0.230	-0.460	-0.690	-0.920	-1.150
	10	50	1.380	1.150	0.920	0.690	0.460	0.230	0.000	-0.230	-0.460	-0.690	-0.920
	20	68	1.610	1.380	1.150	0.920	0.690	0.460	0.230	0.000	-0.230	-0.460	-0.690
	30	86	1.840	1.610	1.380	1.150	0.920	0.690	0.460	0.230	0.000	-0.230	-0.460
	40	104	2.070	1.840	1.610	1.380	1.150	0.920	0.690	0.460	0.230	0.000	-0.230
	50	122	2.300	2.070	1.840	1.610	1.380	1.150	0.920	0.690	0.460	0.230	0.000

Table 3 - Fastener to Structure

T&G PLANKS		PSF (Factored / Ultimate)											
		20	30	40	50	60	70	80	90	100	110	120	
QUICK-SCREEN CLIP SPACING (IN)	16"												
	24"												
	32"												
Plank Profiles: V-Groove (2-1/2", 4", 6"), Smooth (6"), Channel (6"), Lap Siding (6"), Board & Batten Siding (7")													
TRIM COMPONENTS*		PSF (Factored / Ultimate)											
		20	30	40	50	60	70	80	90	100	110	120	
		16"											
Soffit direct to truss		24"											
*Starter Strip requires Two (2) installation anchors at each fastener location: 1 Quick-Screen Clip + 1 Mid-Point slotted hole													
<i>Calculations are using L/180 deflection limits</i>													
SUBSTRATE TYPE	SUBSTRATE REQUIREMENTS		ANCHOR DESCRIPTION		MIN. EMBEDMENT	MIN. EDGE DISTANCE							
WOOD	Min. specific gravity = 0.55 wood		#10 Pan Head Screw		1-1/2"	3/4"							
STEEL	Min. 18 ga., min. 33 ksi.		#10 Tek Screw (grade 5)		3 threads penetration past metal structure	1/2"							
CONCRETE**	Min. 3000 psi		3/16" ITW Tapcon		1"	1"							
MASONRY - CMU**	Grout-filled block per ASTM C-90, min. 2000 psi				1"	2"							
**For Concrete and Masonry/CMU; Furring Strips are recommended, where possible													
GENERAL NOTES:													
1. Adequacy of the structural stud framing (wood and/or metal) and concrete/masonry as a main wind force resisting system capable of withstanding and transferring applied product loads to the foundation is the responsibility of the engineer or architect of record for the project of installation.													
2. Substrate shall be designed and anchored to properly transfer all loads to the structure buck design and installation is the responsibility of the engineer or architect of record for the project of installation.													
3. The installation details described herein are generic and may not reflect actual conditions for a specific site. If site conditions cause installation to deviate from the requirements detailed herein, a licensed engineer or architect shall prepare site specific documents for use with this document.													
4. An unfactored dead load of 1.5 psf was assumed for the cladding.													
INSTALLATION NOTES:													
1. One (1) installation anchor is required at each Quick-Screen Clip location. Minimum of two (2) anchors per plank.													
2. Spacing is from clip/fastener center to center.													
3. The number of installation anchors per the table is the minimum number of anchors to be used for product installation.													
4. Install individual installation anchors within a tolerance of +/- 1/2" of the specified spacings. Tolerances are not cumulative from one installation anchor to the next.													
5. If fastening to every second stud, the attachment stud shall be staggered between adjacent runs of cladding.													
6. Minimum embedment and edge distance exclude wall finishes, including but not limited to wood furrings, stucco, foam, brick veneer, sheathing and siding.													
7. Installation anchors and associated hardware must be made of corrosion resistant material or have a corrosion resistant coating. Common fastener types can be equal or better to a & b listed below:													
a. Zinc plated fasteners for moderate climate zones													
b. 316 Stainless Steel fasteners for coastal climate zones													
8. For CMU grout filled block, do not install installation anchors into mortar joints. Edge distance is measured from free edge of block or edge of mortar joint into face shell of block.													
9. Installation anchors shall be installed in accordance with anchor manufacturer's installation instructions, and anchors shall not be used in substrates with strengths less than the minimum strength specified by the anchor manufacturer.													

Table 4 - Fastener to Sheathing (2-1/2" Planks)

2-1/2" PLANKS		PSF (Factored / Ultimate)										
		20	30	40	50	60	70	80	90	100	110	120
QUICK-SCREEN CLIP SPACING (IN)	24"											
	32"											
Plank Profile: 2-1/2" V-Groove												
TRIM COMPONENTS*		PSF (Factored / Ultimate)										
		20	30	40	50	60	70	80	90	100	110	120
	16"											
*Starter Strip requires Two (2) installation anchors at each fastener location: 1 Quick-Screen Clip + 1 Mid-Point slotted hole												
<i>Calculations are using L/60 deflection limits</i>												
SUBSTRATE TYPE	SUBSTRATE REQUIREMENTS	ANCHOR DESCRIPTION	MIN. SCREW LENGTH	MIN. EMBEDMENT	MIN. EDGE DISTANCE							
7/16" OSB/PLYWOOD	APA rated sheathing or better	#10 Pan Head Wood Screw	1"	7/16"	1"							
GENERAL NOTES:												
1. Substrate shall be designed and anchored to properly transfer all loads to the structure buck design and installation is the responsibility of the engineer or architect of record for the project of installation.												
2. The installation details described herein are generic and may not reflect actual conditions for a specific site. If site conditions cause installation to deviate from the requirements detailed herein, a licensed engineer or architect shall prepare site specific documents for use with this document.												
3. An unfactored dead load of 1.5 psf was assumed for the cladding.												
INSTALLATION NOTES:												
1. One (1) installation anchor is required at each Quick-Screen Clip location. Minimum of two (2) anchors per plank.												
2. Spacing is from clip/fastener center to center.												
3. The number of installation anchors per the table is the minimum number of anchors to be used for product installation.												
4. Install individual installation anchors within a tolerance of +/- 1/2" of the specified spacings. Tolerances are not cumulative from one installation anchor to the next.												
5. Installation anchors and associated hardware must be made of corrosion resistant material or have a corrosion resistant coating. Common fastener types can be equal or better to a & b listed below:												
a. Zinc plated fasteners for moderate climate zones												
b. 316 Stainless Steel fasteners for coastal climate zones												
6. Installation anchors shall be installed in accordance with anchor manufacturer's installation instructions, and anchors shall not be used in substrates with strengths less than the minimum strength specified by the anchor manufacturer.												
REFERENCED DATA:												
2023 Florida Building Code												
2018 National Design Specification for Wood Construction												
Fastener Loads for Plywood - Screws (2011 APA - Engineered Wood Association)												

Table 5 - Fastener to Sheathing (4" Planks)

4" PLANKS		PSF (Factored / Ultimate)										
		20	30	40	50	60	70	80	90	100	110	120
QUICK-SCREEN CLIP SPACING (IN)	16"											
	24"											
	32"											
Plank Profile: 4" V-Groove												
TRIM COMPONENTS*		PSF (Factored / Ultimate)										
		20	30	40	50	60	70	80	90	100	110	120
		16"										
*Starter Strip requires Two (2) installation anchors at each fastener location: 1 Quick-Screen Clip + 1 Mid-Point slotted hole												
<i>Calculations are using L60 deflection limits</i>												
SUBSTRATE TYPE	SUBSTRATE REQUIREMENTS	ANCHOR DESCRIPTION	MIN. SCREW LENGTH	MIN. EMBEDMENT	MIN. EDGE DISTANCE							
7/16" OSB/PLYWOOD	APA rated sheathing or better	#10 Pan Head Wood Screw	1"	7/16"	1"							
GENERAL NOTES:												
1. Substrate shall be designed and anchored to properly transfer all loads to the structure buck design and installation is the responsibility of the engineer or architect of record for the project of installation.												
2. The installation details described herein are generic and may not reflect actual conditions for a specific site. If site conditions cause installation to deviate from the requirements detailed herein, a licensed engineer or architect shall prepare site specific documents for use with this document.												
3. An unfactored dead load of 1.5 psf was assumed for the cladding.												
INSTALLATION NOTES:												
1. One (1) installation anchor is required at each Quick-Screen Clip location. Minimum of two (2) anchors per plank.												
2. Spacing is from clip/fastener center to center.												
3. The number of installation anchors per the table is the minimum number of anchors to be used for product installation.												
4. Install individual installation anchors within a tolerance of +/- 1/2" of the specified spacings. Tolerances are not cumulative from one installation anchor to the next.												
5. Installation anchors and associated hardware must be made of corrosion resistant material or have a corrosion resistant coating. Common fastener types can be equal or better to a & b listed below:												
a. Zinc plated fasteners for moderate climate zones												
b. 316 Stainless Steel fasteners for coastal climate zones												
6. Installation anchors shall be installed in accordance with anchor manufacturer's installation instructions, and anchors shall not be used in substrates with strengths less than the minimum strength specified by the anchor manufacturer.												
REFERENCED DATA:												
2023 Florida Building Code												
2018 National Design Specification for Wood Construction												
Fastener Loads for Plywood - Screws (2011 APA - Engineered Wood Association)												

Table 6 - Fastener to Sheathing (6" Planks)

6" Planks, 6" Lap Siding, 7" Board & Batten		PSF (Factored / Ultimate)										
		20	30	40	50	60	70	80	90	100	110	120
QUICK-SCREEN CLIP SPACING (IN)	12"											
	16"											
	24"											
	32"											
Plank Profiles: 6" V-Groove, 6" Smooth, 6" Channel, 6" Lap, 7" Board & Batten												
TRIM COMPONENTS*		PSF (Factored / Ultimate)										
		20	30	40	50	60	70	80	90	100	110	120
		16"										
*Starter Strip requires Two (2) installation anchors at each fastener location: 1 Quick-Screen Clip + 1 Mid-Point slotted hole												
<i>Calculations are using L/60 deflection limits</i>												
SUBSTRATE TYPE	SUBSTRATE REQUIREMENTS	ANCHOR DESCRIPTION	MIN. SCREW LENGTH	MIN. EMBEDMENT	MIN. EDGE DISTANCE							
7/16" OSB/PLYWOOD	APA rated sheathing or better	#10 Pan Head Wood Screw	1"	7/16"	1"							
GENERAL NOTES:												
1. Substrate shall be designed and anchored to properly transfer all loads to the structure buck design and installation is the responsibility of the engineer or architect of record for the project of installation.												
2. The installation details described herein are generic and may not reflect actual conditions for a specific site. If site conditions cause installation to deviate from the requirements detailed herein, a licensed engineer or architect shall prepare site specific documents for use with this document.												
3. An unfactored dead load of 1.5 psf was assumed for the cladding.												
INSTALLATION NOTES:												
1. One (1) installation anchor is required at each Quick-Screen Clip location. Minimum of two (2) anchors per plank.												
2. Spacing is from clip/fastener center to center.												
3. The number of installation anchors per the table is the minimum number of anchors to be used for product installation.												
4. Install individual installation anchors within a tolerance of +/- 1/2" of the specified spacings. Tolerances are not cumulative from one installation anchor to the next.												
5. Installation anchors and associated hardware must be made of corrosion resistant material or have a corrosion resistant coating. Common fastener types can be equal or better to a & b listed below:												
a. Zinc plated fasteners for moderate climate zones												
b. 316 Stainless Steel fasteners for coastal climate zones												
6. Installation anchors shall be installed in accordance with anchor manufacturer's installation instructions, and anchors shall not be used in substrates with strengths less than the minimum strength specified by the anchor manufacturer.												
REFERENCED DATA:												
2023 Florida Building Code												
2018 National Design Specification for Wood Construction												
Fastener Loads for Plywood - Screws (2011 APA - Engineered Wood Association)												

Proper Handling of Longboard Products



To help avoid injury and product damage, Longboard products require proper handling to and from storage areas during installation. When carrying or installing any products it is recommended that they be moved or carried by at least two people with each support point approximately 4ft from the ends. **Carrying products without proper support can cause excessive bending which may damage the appearance or finish of the product.** Any short cut lengths should also be carried on edge while supporting the material. See below for details.

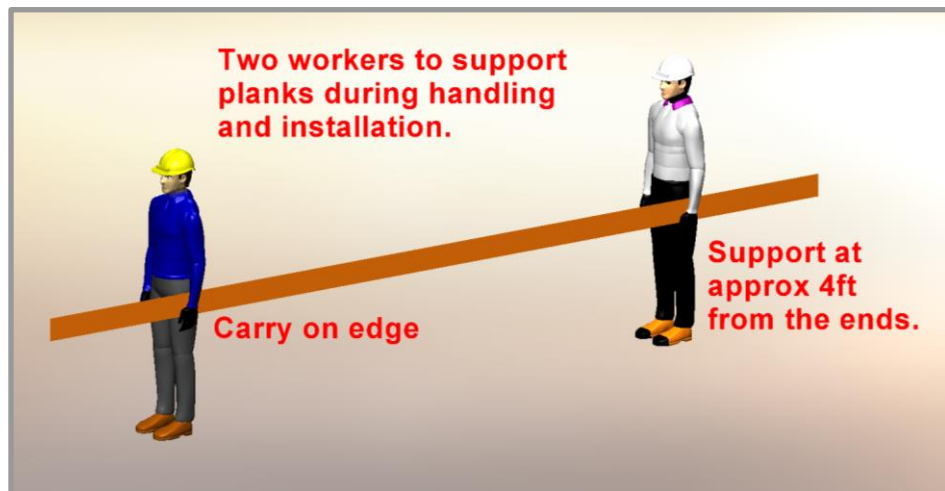
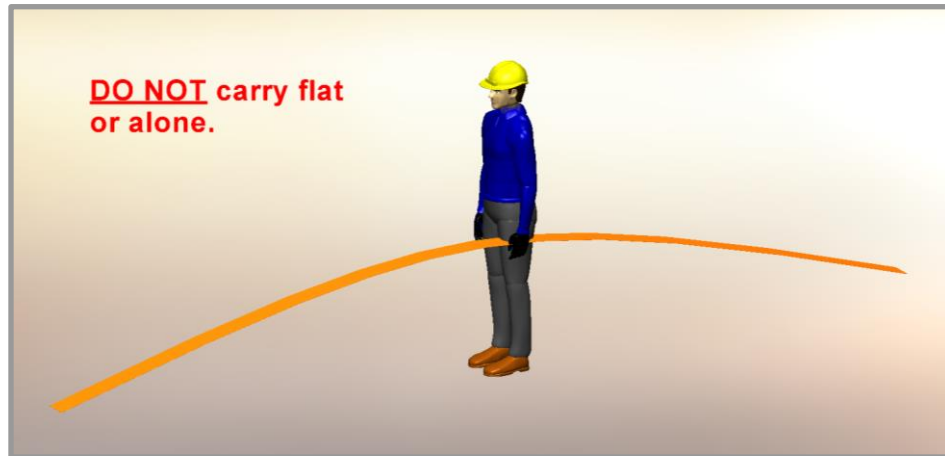

⚠️ Delivery, Storage & Handling ⚠️

- Always inspect the delivery for damage and contact LB ASAP if there are any issues: info@longboardproducts.com or 1-800-604-0343 and include your PO# and any pictures if possible. Longboard is not responsible for the installation of blemished or damaged material.
- Be sure to store the material flat, keep it dry, safe & secure and remain in unopened cartons until ready to be installed.
- Always wear appropriate PPE when handling products.



Longboard Architectural Products Inc.
© Longboard Architectural Products Inc. All rights reserved.

Longboard® is a registered trademark of Longboard Architectural Products Inc.

Longboard
1777 Clearbrook Road
Abbotsford, BC V2T 8X8
Canada
longboardproducts.com

Every effort has been made to ensure that the information in these installation guidelines is accurate. Longboard is not responsible for printing or clerical errors.

For more information, contact client care at info@longboardproducts.com or call toll free 1-800-604-0343.