

# PANELBOARD™

## INTERIOR WALL SYSTEM

### TYPICAL ISOMETRIC

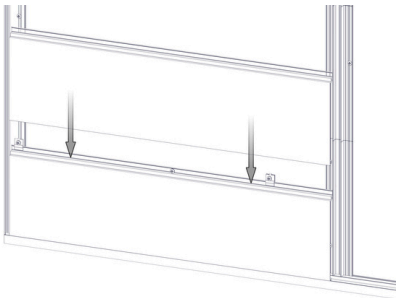

### PROFILES

Smooth: 6"  
Standard Lengths: 24'  
96 SQ FT/box

### COMPONENTS - Standard Lengths: 12'

**Traditional:** 2" Corner Set, 1-3/8" Two Piece J-Track, 1-3/8" Termination Set, Compression Joint (24'), 1-1/2" Flat Reveal Set, 1-1/2" U-Reveal Set, 1-1/2" T&G U-Reveal

**Craftsman:** 3/4" Inside Corner, 1" Outside Corner, 3/4" U-Reveal Set, 3/4" T&G U-Reveal

**Precision:** 5/8" Starter J-Track, 3/16" Outside Corner, 5/8" J-Track, 5/8" Two Piece J-Track, 5/8" Termination Set, 1/2" Flat Reveal, 1/2" T&G Flat Reveal

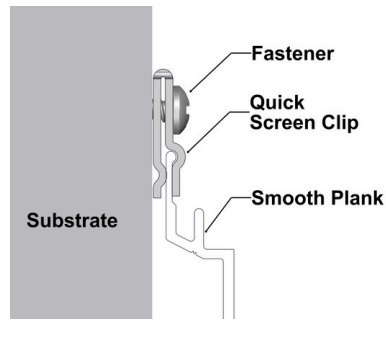

### FINISHES

Woodgrains, solid color, naturally aged metal, custom solid colour matching (additional lead times apply)

### ATTACHMENT

Planks: Quick-screen clips w. #10 Pan Head screws\* @ 32" o.c. (standard).  
Quick-screen clips included: 135 pcs/4" box, 90 pcs/6" box.  
Trims: hard fasten w. #10 Pan Head screws\* @ 16" o.c. \*Screws not included.

### BIM & CAD

RVT & DWG files available, see website for details

### LEAD TIME

Most Popular Finishes  
-ready to ship within 1 week  
Additional Finishes  
-ready to ship within 14 weeks

### TECHNICAL SPECIFICATIONS

#### PHYSICAL DATA

6063-T5 Extruded Aluminum  
100% Recyclable  
Warranty: Finish:15 year (standard)/20 year\* (ultra) (\*10 week lead time);  
Aluminum: 50 year  
Weight (lbs/sqft): ~1.5  
6" Perforated Planks provide 21% open area

#### TESTING

ICC-ESR 4182 Evaluation Report

LARR - Los Angeles Department of Building Safety (LADBS) accepts ICC-ES reports as proof of compliance

Impact testing: TAS 201



**Fire Rating:** Class A Non-Combustible by ASTM E136 & ASTM E84 ; A2-s1,d0 by EN 13501-1



**Light Reflectance:** 5% (Black) up to 73.2% (Ultra White)



[info@longboardproducts.com](mailto:info@longboardproducts.com)  
[longboardproducts.com](http://longboardproducts.com)  
800 604 0343