



LONGBOARD®
INSPIRING ARCHITECTURE

LINK & LOCK™ INFO SHEETS

INCLUDING

LINK & LOCK™ HD

LINK & LOCK™ BRACKETS

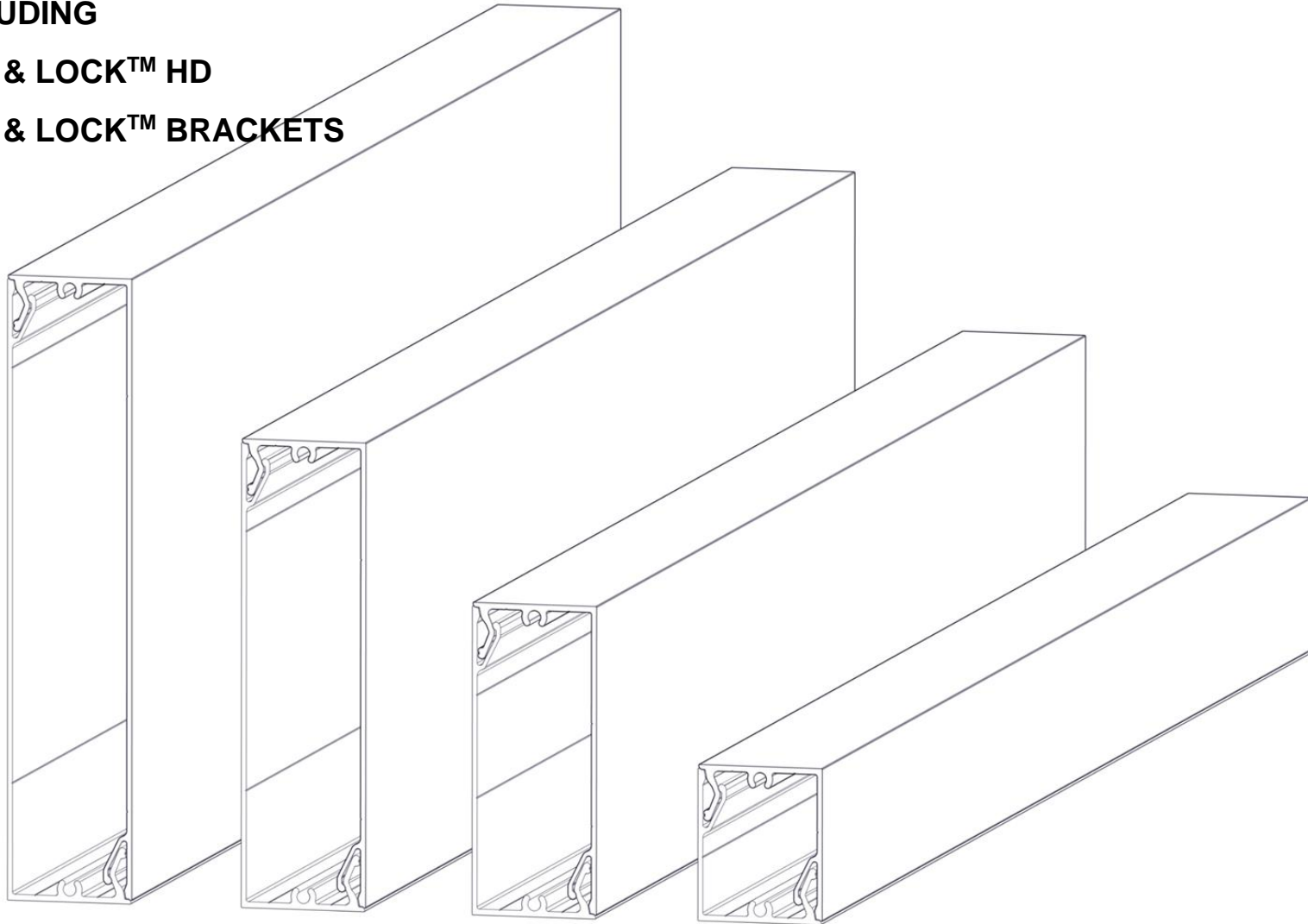

L&L Dimensions

Finishes:

Woodgrains, Solid, Specialty

Custom Solid Color Matching - (Additional lead times apply)



2" Link & Lock



4" Link & Lock



6" Link & Lock



8" Link & Lock

Actual Sizes & Weights

L&L	Width	Depth	Length	Weight(lbs/LF) *per set
2"	2" (50.8mm)	1 5/8" (41.3mm)	12'/24'	0.93
4"	4" (101.6mm)	1 5/8" (41.3mm)	12'/24'	1.3
6"	6" (152.4mm)	1 5/8" (41.3mm)	12'/24'	1.6
8"	8" (203mm)	1 5/8" (41.3mm)	12'/24'	1.9
4"x4"	4" (101.6mm)	4" (101.6mm)	12'/24'	1.8
4"x6"	4" (101.6mm)	6" (152.4mm)	12'/24'	2.1

Physical data:

- 6063-T5 Extruded Aluminum
- 100% recyclable
- Warranty on Finish: 15 year (standard)/20 year* (ultra) (*10week lead time); Aluminum: 50 year

Link & Lock™ Battens

Size	12'	24'	End Caps (20/box)	End Mounts (20/box)
2"	2X2LL.145	2X2LL.289	2LLEC.2	2LLEM.2
4"	2X4LL.145	2X4LL.289	2LLEC.4	2LLEM.4
6"	2X6LL.145	2X6LL.289	2LLEC.6	2LLEM.6
8"	2X8LL.145	2X8LL.289	2LLEC.8	2LLEM.8

Link & Lock™ Box Battens

4 x 4"	4X4LL.145	4X4LL.289	4LLEC.4	-
4 x 6"	4X6LL.145	4X6LL.289	4LLEC.6	-

Mounting Accessories	Qty	SKU
Link & Lock Mounting Clip	48, bag	LLMC.N48
Link & Lock™ Isolation Washer	48, bag	FAST.5003.BOX48
Dewalt® 1/2" Pilot Point Drill Bit	1	DRILLBT.05
24' Link & Lock Internal Stiffener	1	LLSTIFF.289
3M® Double Sided Adhesive Tape - 108'	1, roll	LLTAPE.1296



4"x4" Link & Lock



4"x6" Link & Lock

L&L Installation Components [See L&L Install Guide for details](#)



Mounting Clip:

- Nylon with embedded SS washer
- Used on Batten and Fin orientation to secure the back "L" to the substrate
- Included in order with L&L for 6' O.C. attachment
- Additional Clips purchased separately (48 pcs/box)



End Mount:

- Extruded 6063-T5 Aluminum Alloy, powder coated black
- Used for End-to-End attachment to provide a solid mount for the L&L set to wrap around and snap together
- Available for 2", 4", 6" & 8" L&L
- Purchased separately (20 pcs/box)



#12 Fastener (By others):

- Zinc-plated or Stainless Steel
- Used for attaching the back "L" to the substrate
- Use the correct fastener for the required project substrate
- Supplied by others



Isolation Washer:

- PA6 Nylon
- Used to isolate the back "L" from the substrate
- Max. 4x to shim L&L (1/4" total)
- 1/16" thick, 1 1/2" O.D.
- Purchased separately in packages of 48



1/2" Pilot Point Drill Bit:

- 1/2" Pilot Point Drill Bit
- Used for Drilling out the holes for mounting the L&L to the substrate
- See Install Guide for drilling details



Paint Pen:

- Color choices available
- Used for touch ups at the ends before installing End Caps
- Purchased separately



Double-sided Adhesive Tape:

- 3M VHB Tape
- Used for attaching the Internal Stiffener to the back "L" of the L&L set
- Tape is placed in the center of the Stiffener



Internal Stiffener:

- Extruded 6063-T5 Aluminum Alloy (comes powder coated black)
- Used for reinforcing the 4", 6" & 8" L&L to allow for up to 12' spans between attachment points
- See Testing and Loading page for span allowance

L&L Install Images

See L&L Install Guide for details

BIM & CAD: RVT & DWG files available, see website for details

Mounting Clip (Fin orientation)

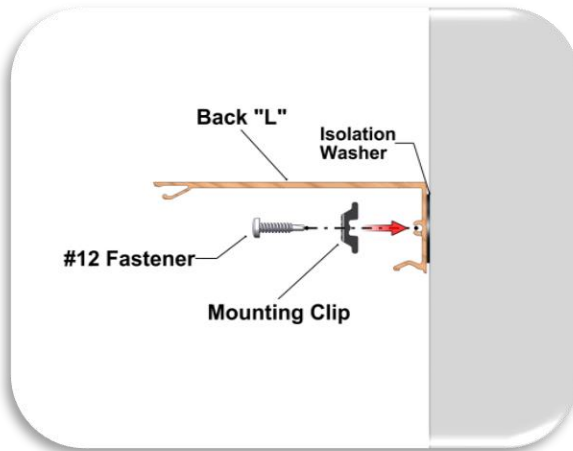

End Mount

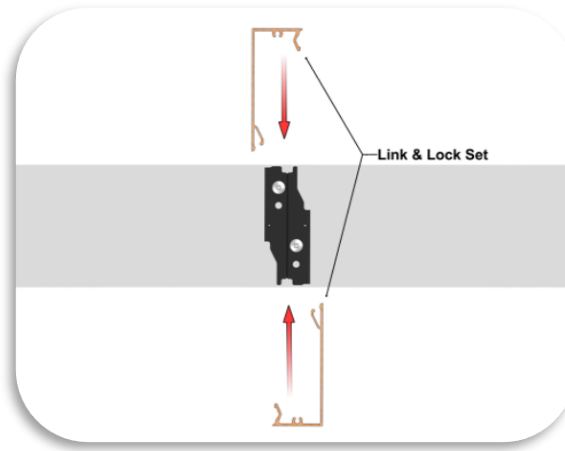

Internal Stiffener (with Double-sided Tape)

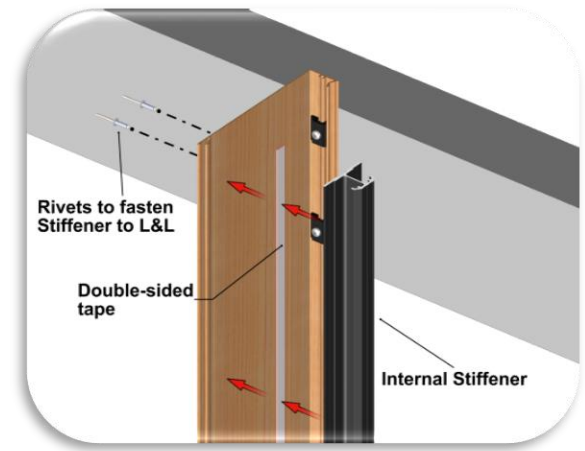

Mounting Clip (Batten orientation)

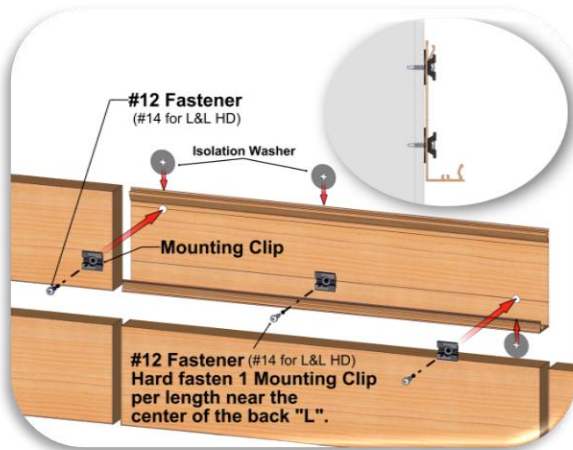

Paint Pen (for cut edges)

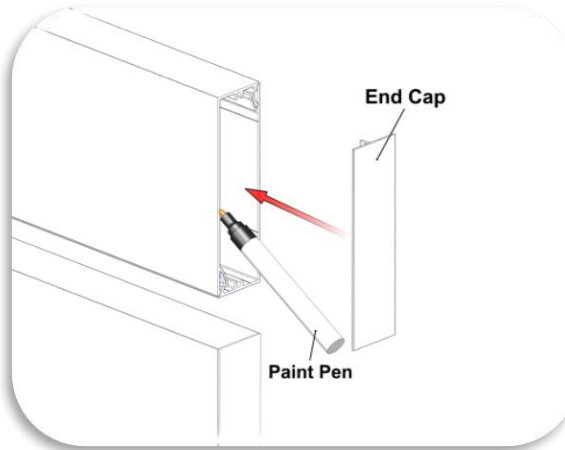

Drilling (Fin orientation)

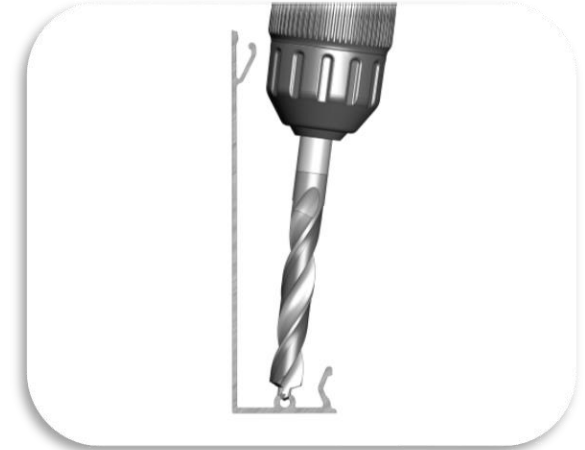

L&L HD Components

Finishes:
Woodgrains, Solid, Specialty
Custom Solid Color Matching - (Additional lead times apply)



4" Link & Lock HD



6" Link & Lock HD

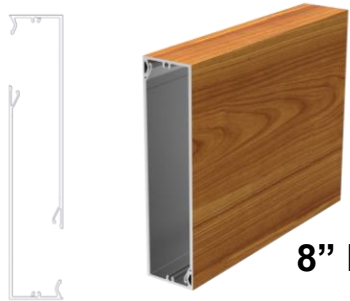

8" Link & Lock HD



Link & Lock HD End Mount

Actual Sizes & Weights

L&L	Width	Depth	Length	Weight(lbs/LF) *per set
4"	4" (101.6mm)	2" (50.8mm)	12'/24'	1.7
6"	6" (152.4mm)	2" (50.8mm)	12'/24'	2.4
8"	8" (203mm)	2" (50.8mm)	12'/24'	3

Size	12'	24'	End Caps (20/box)	End Mounts (20/box)
4"	2X4LLHD.145	2X4LLHD.289	2LLHDEC.4	2LLHDEM.4
6"	2X6LLHD.145	2X6LLHD.289	2LLHDEC.6	2LLHDEM.6
8"	2X8LLHD.145	2X8LLHD.289	2LLHDEC.8	2LLHDEM.8

Mounting Accessories	Qty	SKU
Link & Lock Mounting Clip	48, bag	LLMC.N48
Link & Lock™ Isolation Washer	48, bag	FAST.5003.BOX48
Dewalt® 1/2" Pilot Point Drill Bit	1	DRILLBT.05

Physical data:

- 6063-T5 Extruded Aluminum
- 100% recyclable
- Warranty on Finish: 15 year (standard)/20 year* (ultra) (*10week lead time); Aluminum: 50 year

BIM & CAD:

- RVT & DWG files to be available

Mounting Clip:



- Nylon with embedded SS washer
- Used on Batten and Fin orientation to secure the back "L" to the substrate
- Included in order with L&L for 6' O.C. attachment
- Additional Clips purchased separately (48 pcs/bag)

1/2" Pilot Point Drill Bit:



- 1/2" Pilot Point Drill Bit
- Used for Drilling out the holes for mounting the L&L to the substrate
- See Install Guide for drilling details

Isolation Washer:



- PA6 Nylon
- Used to isolate the back "L" from the substrate
- Max. 4x to shim L&L (1/4" total)
- 1/16" thick, 1 1/2" O.D.
- Purchased separately in packages of 48

#14 Fastener



- Eng. & Load Dependent (By others):
- Zinc-plated or Stainless Steel
- Used for attaching the back "L" to the substrate
- Use the correct fastener for the required project substrate
- Supplied by others

L&L Testing Data and Allowable Spans

See L&L Install Guide for details

2" LINK & LOCK™		FASTENER SPACING - LOAD TABLE										
		PSF (Factored / Ultimate)										
Standard		20	30	40	50	60	70	80	90	100	110	120
ALLOWABLE SPAN (FT)	4'											
	6'											
	8'											
	10'											

*CANTILEVERS are not to exceed half (1/2) the allowable span to a maximum of 3'

Calculations are using L/180 deflection limits

SUBSTRATE TYPE	SUBSTRATE REQUIREMENTS	ANCHOR DESCRIPTION	MIN. EMBEDMENT	MIN. EDGE DISTANCE
WOOD	Min. specific gravity = 0.55 wood	#12 Pan Head Wood Screw	1-1/2"	1"
STEEL	Min. 18 ga., Min. Fy=33 ksi.	#12 Self-Drilling or Self-Tapping Screw (Grade 5)	3 threads penetration past metal structure	1/2"
ALUMINUM	Min. 1/8", Min. 6063-T5			
CONCRETE	Min. 3000 psi	3/16" ITW Tapcon	1-1/2"	1-3/4"
HOLLOW/GROUT-FILLED CMU	Conforms to ASTM C-90, with Min. compressive strength of 2000 psi		1"	2"

GENERAL NOTES:

- This product has been designed and manufactured to comply with the current Florida Building Code (FBC), **INCLUDING** HVHZ and has been evaluated according to the following:
 - Section 1709.8
 - ASTM E8-16
- Adequacy of the structural concrete/masonry and 2X framing as a main wind force resisting system capable of withstanding and transferring applied product loads to the foundation is the responsibility of the engineer or architect of record for the project of installation.
- Substrate shall be designed and anchored to properly transfer all loads to the structure. Buck design and installation is the responsibility of the engineer or architect of record for the project of installation.
- The installation details described herein are generic and may not reflect actual conditions for a specific site. If site conditions cause installation to deviate from the requirements detailed herein, a licensed engineer or architect shall prepare site specific documents for use with this document.
- Link & Lock is not designed to be a life-safety item. Designs of this nature are the responsibility of the engineer or architect of record.

INSTALLATION NOTES:

- One (1) installation anchor is required at each location. Minimum of two (2) anchors per batten.
- Spacing is from fastener center to center.
- The number of installation anchors per the table is the minimum number of anchors to be used for product installation.
- Install individual installation anchors within a tolerance of +/- 1/2" of the specified spacings. Tolerances are not cumulative from one installation anchor to the next.
- Minimum embedment and edge distance exclude wall finishes, including but not limited to stucco, foam, brick veneer, sheathing and siding.
- Installation anchors and associated hardware must be made of corrosion resistant material or have a corrosion resistant coating. Common fastener types can be equal or better to a & b listed below.
 - Zinc plated fasteners for moderate climate zones
 - 316 Stainless Steel fasteners for coastal climate zones
- For hollow block and grout filled CMU block, do not install installation anchors into mortar joints. Edge distance is measured from free edge of block or edge of mortar joint into face shell of block.
- Installation anchors shall be installed in accordance with anchor manufacturer's installation instructions, and anchors shall not be used in substrates with strengths less than the minimum strength specified by the anchor manufacturer.
- When using end mounts, span distance is measured center to center of each end mount.

Testing:
 ICC-ESR 4183 Evaluation Report -
 Division: 05 00 00 – METALS
 • Section: 05 50 00 - Metal Fabrications

LARR - Los Angeles Department of Building Safety (LADBS) accepts ICC-ES reports as proof of compliance

Florida Product Code: FL41842

International Building Code (IBC).
 International Residential Code (IRC)
 California Building Code (CBC)
 California Residential Code (CRC)
 City of Los Angeles Building Code (LABC), City of Los Angeles Residential Code (LARC)
 Florida Building Code – Building
 Florida Building Code - Residential

 Fire Rating: Class A Non-Combustible by ASTM E136 & ASTM E84

 Light Reflectance: 5% (Black) up to 73.2% (Ultra White)

FASTENER SPACING - LOAD TABLE

4" LINK & LOCK™			PSF (Factored / Ultimate)												
			20	30	40	50	60	70	80	90	100	110	120		
Standard	Standard w. Stiffener	HD													
ALLOWABLE SPAN (FT)*	2'														
	4'									Standard w. Stiffener					
	6'							Standard w. Stiffener		HD					
	8'				Standard w. Stiffener			HD							
	10'		Standard w. Stiffener			HD									
	12'		Standard w. Stiffener		HD										

*CANTILEVERS are not to exceed half (1/2) the allowable span to a maximum of 3'

Calculations are using L/180 deflection limits

SUBSTRATE TYPE	SUBSTRATE REQUIREMENTS	ANCHOR DESCRIPTION	MIN. EMBEDMENT	MIN. EDGE DISTANCE
WOOD	Min. specific gravity = 0.55 wood	#12 Pan Head Wood Screw	1-1/2"	1"
STEEL	Min. 18 ga., Min. Fy=33 ksi.	#12 Self-Drilling or Self-Tapping Screw (Grade 5)	3 threads penetration past metal structure	1/2"
ALUMINUM	Min. 1/8", Min. 6063-T5			
CONCRETE	Min. 3000 psi	3/16" ITW Tapcon	1-1/2"	1-3/4"
HOLLOW/GROUT-FILLED CMU	Conforms to ASTM C-90, with Min. compressive strength of 2000 psi		1"	2"

GENERAL NOTES:

- This product has been designed and manufactured to comply with the current Florida Building Code (FBC), **INCLUDING** HVHZ and has been evaluated according to the following:
 - Section 1709.8
 - ASTM E8-16
- Adequacy of the structural concrete/masonry and 2X framing as a main wind force resisting system capable of withstanding and transferring applied product loads to the foundation is the responsibility of the engineer or architect of record for the project of installation.
- Substrate shall be designed and anchored to properly transfer all loads to the structure. Buck design and installation is the responsibility of the engineer or architect of record for the project of installation.
- The installation details described herein are generic and may not reflect actual conditions for a specific site. If site conditions cause installation to deviate from the requirements detailed herein, a licensed engineer or architect shall prepare site specific documents for use with this document.
- Link & Lock is not designed to be a life-safety item. Designs of this nature are the responsibility of the engineer or architect of record.

INSTALLATION NOTES:

- One (1) installation anchor is required at each location. Minimum of two (2) anchors per batten.
- Spacing is from fastener center to center.
- The number of installation anchors per the table is the minimum number of anchors to be used for product installation.
- Install individual installation anchors within a tolerance of +/- 1/2" of the specified spacings. Tolerances are not cumulative from one installation anchor to the next.
- Minimum embedment and edge distance exclude wall finishes, including but not limited to stucco, foam, brick veneer, sheathing and siding.
- Installation anchors and associated hardware must be made of corrosion resistant material or have a corrosion resistant coating. Common fastener types can be equal or better to a & b listed below.
 - Zinc plated fasteners for moderate climate zones
 - 316 Stainless Steel fasteners for coastal climate zones
- For hollow block and grout filled CMU block, do not install installation anchors into mortar joints. Edge distance is measured from free edge of block or edge of mortar joint into face shell of block.
- Installation anchors shall be installed in accordance with anchor manufacturer's installation instructions, and anchors shall not be used in substrates with strengths less than the minimum strength specified by the anchor manufacturer.
- When using end mounts, span distance is measured center to center of each end mount.

FASTENER SPACING - LOAD TABLE

6" LINK & LOCK™			PSF (Factored / Ultimate)											
Standard	Standard w. Stiffener	HD	20	30	40	50	60	70	80	90	100	110	120	
ALLOWABLE SPAN (FT)*			2'											
			4'										Standard w. Stiffener	
			6'				Standard w. Stiffener	HD						
			8'	Standard w. Stiffener		HD								
			10'	Standard w. Stiffener	HD									
			12'	HD										

*CANTILEVERS are not to exceed half (1/2) the allowable span to a maximum of 3'

Calculations are using L/180 deflection limits

SUBSTRATE TYPE	SUBSTRATE REQUIREMENTS	ANCHOR DESCRIPTION	MIN. EMBEDMENT	MIN. EDGE DISTANCE
WOOD	Min. specific gravity = 0.55 wood	#12 Pan Head Wood Screw	1-1/2"	1"
STEEL	Min. 18 ga., Min. Fy=33 ksi.	#12 Self-Drilling or Self-Tapping Screw (Grade 5)	3 threads penetration past metal structure	1/2"
ALUMINUM	Min. 1/8", Min. 6063-T5			
CONCRETE	Min. 3000 psi	3/16" ITW Tapcon	1-1/2"	1-3/4"
HOLLOW/GROUT-FILLED CMU	Conforms to ASTM C-90, with Min. compressive strength of 2000 psi		1"	2"

GENERAL NOTES:

- This product has been designed and manufactured to comply with the current Florida Building Code (FBC), **INCLUDING** HVHZ and has been evaluated according to the following:
 - Section 1709.8
 - ASTM E8-16
- Adequacy of the structural concrete/masonry and 2X framing as a main wind force resisting system capable of withstanding and transferring applied product loads to the foundation is the responsibility of the engineer or architect of record for the project of installation.
- Substrate shall be designed and anchored to properly transfer all loads to the structure. Buck design and installation is the responsibility of the engineer or architect of record for the project of installation.
- The installation details described herein are generic and may not reflect actual conditions for a specific site. If site conditions cause installation to deviate from the requirements detailed herein, a licensed engineer or architect shall prepare site specific documents for use with this document.
- Link & Lock is not designed to be a life-safety item. Designs of this nature are the responsibility of the engineer or architect of record.

INSTALLATION NOTES:

- One (1) installation anchor is required at each location. Minimum of two (2) anchors per batten.
- Spacing is from fastener center to center.
- The number of installation anchors per the table is the minimum number of anchors to be used for product installation.
- Install individual installation anchors within a tolerance of +/- 1/2" of the specified spacings. Tolerances are not cumulative from one installation anchor to the next.
- Minimum embedment and edge distance exclude wall finishes, including but not limited to stucco, foam, brick veneer, sheathing and siding.
- Installation anchors and associated hardware must be made of corrosion resistant material or have a corrosion resistant coating. Comm on fastener types can be equal or better to a & b listed below:
 - Zinc plated fasteners for moderate climate zones
 - 316 Stainless Steel fasteners for coastal climate zones
- For hollow block and grout filled CMU block, do not install installation anchors into mortar joints. Edge distance is measured from free edge of block or edge of mortar joint into face shell of block.
- Installation anchors shall be installed in accordance with anchor manufacturer's installation instructions, and anchors shall not be used in substrates with strengths less than the minimum strength specified by the anchor manufacturer.
- When using end mounts, span distance is measured center to center of each end mount.

FASTENER SPACING - LOAD TABLE

8" LINK & LOCK™			PSF (Factored / Ultimate)											
			20	30	40	50	60	70	80	90	100	110	120	
Standard	Standard w. Stiffener	HD												
ALLOWABLE SPAN (FT)*	2'													
	4'					Standard w. Stiffener							HD	
	6'			Standard w. Stiffener	HD									
	8'	Standard w. Stiffener	HD											
	10'	HD												

*CANTILEVERS are not to exceed half (1/2) the allowable span to a maximum of 3'

Calculations are using L/180 deflection limits

SUBSTRATE TYPE	SUBSTRATE REQUIREMENTS	ANCHOR DESCRIPTION	MIN. EMBEDMENT	MIN. EDGE DISTANCE
WOOD	Min. specific gravity = 0.55 wood	#12 Pan Head Wood Screw	1-1/2"	1"
STEEL	Min. 18 ga., Min. Fy=33 ksi.	#12 Self-Drilling or Self-Tapping Screw (Grade 5)	3 threads penetration past metal structure	1/2"
ALUMINUM	Min. 1/8", Min. 6063-T5			
CONCRETE	Min. 3000 psi	3/16" ITW Tapcon	1-1/2"	1-3/4"
HOLLOW/GROUT-FILLED CMU	Conforms to ASTM C-90, with Min. compressive strength of 2000 psi		1"	2"

GENERAL NOTES:

- This product has been designed and manufactured to comply with the current Florida Building Code (FBC), **INCLUDING** HVHZ and has been evaluated according to the following:
 - Section 1709.8
 - ASTM E8-16
- Adequacy of the structural concrete/masonry and 2X framing as a main wind force resisting system capable of withstanding and transferring applied product loads to the foundation is the responsibility of the engineer or architect of record for the project of installation.
- Substrate shall be designed and anchored to properly transfer all loads to the structure. Buck design and installation is the responsibility of the engineer or architect of record for the project of installation.
- The installation details described herein are generic and may not reflect actual conditions for a specific site. If site conditions cause installation to deviate from the requirements detailed herein, a licensed engineer or architect shall prepare site specific documents for use with this document.
- Link & Lock is not designed to be a life-safety item. Designs of this nature are the responsibility of the engineer or architect of record.

INSTALLATION NOTES:

- One (1) installation anchor is required at each location. Minimum of two (2) anchors per batten.
- Spacing is from fastener center to center.
- The number of installation anchors per the table is the minimum number of anchors to be used for product installation.
- Install individual installation anchors within a tolerance of +/- 1/2" of the specified spacings. Tolerances are not cumulative from one installation anchor to the next.
- Minimum embedment and edge distance exclude wall finishes, including but not limited to stucco, foam, brick veneer, sheathing and siding.
- Installation anchors and associated hardware must be made of corrosion resistant material or have a corrosion resistant coating. Common fastener types can be equal or better to a & b listed below:
 - Zinc plated fasteners for moderate climate zones
 - 316 Stainless Steel fasteners for coastal climate zones
- For hollow block and grout filled CMU block, do not install installation anchors into mortar joints. Edge distance is measured from free edge of block or edge of mortar joint into face shell of block.
- Installation anchors shall be installed in accordance with anchor manufacturer's installation instructions, and anchors shall not be used in substrates with strengths less than the minimum strength specified by the anchor manufacturer.
- When using end mounts, span distance is measured center to center of each end mount.

FASTENER SPACING - LOAD TABLE

4X4 LINK & LOCK™		PSF (Factored / Ultimate)										
		20	30	40	50	60	70	80	90	100	110	120
Standard												
ALLOWABLE SPAN (FT)*		8'										
		10'										
		12'										

*CANTILEVERS are not to exceed 3'

Calculations are using L/180 deflection limits

SUBSTRATE TYPE	SUBSTRATE REQUIREMENTS	ANCHOR DESCRIPTION	MIN. EMBEDMENT	MIN. EDGE DISTANCE
WOOD	Min. specific gravity = 0.55 wood	#12 Pan Head or Flanged Hex Head Wood Screw	1-1/2"	1"
STEEL	Min. 18 ga., Min. Fy=36 ksi.	#12 Self-Drilling or Self-Tapping Screw Pan Head or Flanged Hex Head Wood Screw (Grade 5)	3 threads penetration past metal structure	1/2"
ALUMINUM	Min. 1/8", Min. 6063-T5			
CONCRETE	Min. 3000 psi	3/16" ITW Tapcon	1-1/2"	1-3/4"
HOLLOW/GROUT-FILLED CMU	Conforms to ASTM C-90, with Min. compressive strength of 2000 psi		1"	2"

GENERAL NOTES:

- Adequacy of the structural concrete/masonry and 2X framing as a main wind force resisting system capable of withstanding and transferring applied product loads to the foundation is the responsibility of the engineer or architect of record for the project of installation.
- Substrate shall be designed and anchored to properly transfer all loads to the structure. Buck design and installation is the responsibility of the engineer or architect of record for the project of installation.
- The installation details described herein are generic and may not reflect actual conditions for a specific site. If site conditions cause installation to deviate from the requirements detailed herein, a licensed engineer or architect shall prepare site specific documents for use with this document.
- Link & Lock is not designed to be a life-safety item. Designs of this nature are the responsibility of the engineer or architect of record.

INSTALLATION NOTES:

- One (1) installation anchor is required at each location. Minimum of two (2) anchors per batten.
- Spacing is from fastener center to center.
- The number of installation anchors per the table is the minimum number of anchors to be used for product installation.
- Install individual installation anchors within a tolerance of +/- 1/2" of the specified spacings. Tolerances are not cumulative from one installation anchor to the next.
- Minimum embedment and edge distance exclude wall finishes, including but not limited to stucco, foam, brick veneer, sheathing and siding.
- Installation anchors and associated hardware must be made of corrosion resistant material or have a corrosion resistant coating. Common fastener types can be equal or better to a & b listed below:
 - Zinc plated fasteners for moderate climate zones
 - 316 Stainless Steel fasteners for coastal climate zones
- For hollow block and grout filled CMU block, do not install installation anchors into mortar joints. Edge distance is measured from free edge of block or edge of mortar joint into face shell of block.
- Installation anchors shall be installed in accordance with anchor manufacturer's installation instructions, and anchors shall not be used in substrates with strengths less than the minimum strength specified by the anchor manufacturer.

4X6 LINK & LOCK™		PSF (Factored / Ultimate)										
		20	30	40	50	60	70	80	90	100	110	120
Standard												
ALLOWABLE SPAN (FT)*	8'											
	10'											
	12'											

*CANTILEVERS are not to exceed 3'

Calculations are using L/180 deflection limits

SUBSTRATE TYPE	SUBSTRATE REQUIREMENTS	ANCHOR DESCRIPTION	MIN. EMBEDMENT	MIN. EDGE DISTANCE
WOOD	Min. specific gravity = 0.55 wood	#12 Pan Head or Flanged Hex Head Wood Screw	1-1/2"	1"
STEEL	Min. 18 ga., Min. Fy=36 ksi.	#12 Self-Drilling or Self-Tapping Screw Pan Head or Flanged Hex Head Wood Screw (Grade 5)	3 threads penetration past metal structure	1/2"
ALUMINUM	Min. 1/8", Min. 6063-T5			
CONCRETE	Min. 3000 psi	3/16" ITW Tapcon	1-1/2"	1-3/4"
HOLLOW/GROUT-FILLED CMU	Conforms to ASTM C-90, with Min. compressive strength of 2000 psi		1"	2"

GENERAL NOTES:

- Adequacy of the structural concrete/masonry and 2X framing as a main wind force resisting system capable of withstanding and transferring applied product loads to the foundation is the responsibility of the engineer or architect of record for the project of installation.
- Substrate shall be designed and anchored to properly transfer all loads to the structure. Buck design and installation is the responsibility of the engineer or architect of record for the project of installation.
- The installation details described herein are generic and may not reflect actual conditions for a specific site. If site conditions cause installation to deviate from the requirements detailed herein, a licensed engineer or architect shall prepare site specific documents for use with this document.
- Link & Lock is not designed to be a life-safety item. Designs of this nature are the responsibility of the engineer or architect of record.

INSTALLATION NOTES:

- One (1) installation anchor is required at each location. Minimum of two (2) anchors per batten.
- Spacing is from fastener center to center.
- The number of installation anchors per the table is the minimum number of anchors to be used for product installation.
- Install individual installation anchors within a tolerance of +/- 1/2" of the specified spacings. Tolerances are not cumulative from one installation anchor to the next.
- Minimum embedment and edge distance exclude wall finishes, including but not limited to stucco, foam, brick veneer, sheathing and siding.
- Installation anchors and associated hardware must be made of corrosion resistant material or have a corrosion resistant coating. Common fastener types can be equal or better to a & b listed below:
 - Zinc plated fasteners for moderate climate zones
 - 316 Stainless Steel fasteners for coastal climate zones
- For hollow block and grout filled CMU block, do not install installation anchors into mortar joints. Edge distance is measured from free edge of block or edge of mortar joint into face shell of block.
- Installation anchors shall be installed in accordance with anchor manufacturer's installation instructions, and anchors shall not be used in substrates with strengths less than the minimum strength specified by the anchor manufacturer.

L&L Bracket Components

Single Bracket for horizontal substrate

Fixed Bracket (Hard fastened with 1/4" holes)

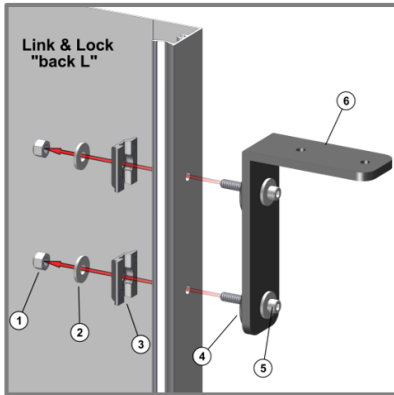

Fixed Bracket (Expansion 1/2" holes)

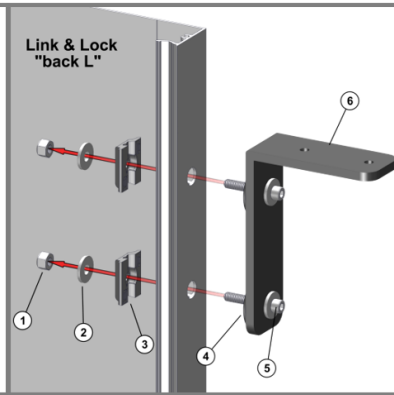

Dual Bracket for vertical substrate

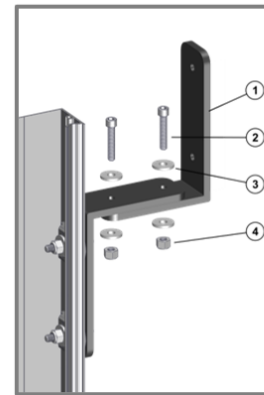

Dual Bracket components are pre-assembled by manufacturer. Do not adjust or remove unless authorized by the manufacturer.

No.	Description	Material	Qty
1	Link & Lock Dual Bracket -90 Center Fixed	6005A Aluminum	1
2	1/4" -20 Socket Head Screw, 1-1/4" length	Stainless Steel	2
3	Washer, 1/4" screw size, 0.75" OD	Stainless Steel	4
4	1/4" -20 Locknut	Stainless Steel Nylon-Insert	2

No.	Description	Material	Qty
1	1/4" -20 Locknut	Stainless Steel Nylon-Insert	2
2	Washer, 1/4" screw size, 0.75" OD	Stainless Steel	4
3	Link & Lock Mounting Clip	Nylon w. Stainless Washer	2
4	Isolation Washer for 1/4" size	Nylon, Black	2
5	1/4" -20 Socket Head Screw, 1-1/2" length	Stainless Steel	2
6	Link & Lock Bracket -90 Center Fixed	6005A Aluminum	1

Sliding Bracket (Use 1/4" holes)

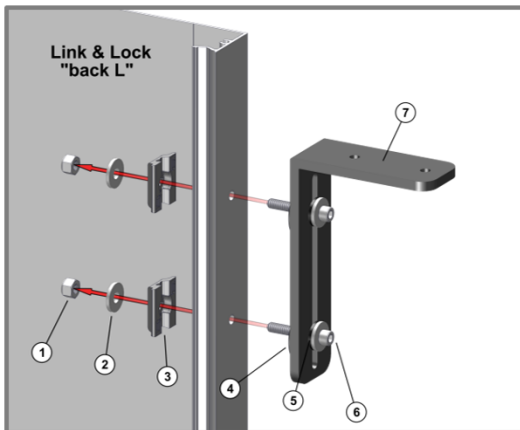

Link & Lock™ Mounting Brackets

Product	Single	Dual
45° LEFT FIXED	LLMBK.45LF	LLMDK.45LF
45° RIGHT FIXED	LLMBK.45RF	LLMDK.45RF
90° CENTER FIXED	LLMBK.90F	LLMDK.90F
45° LEFT SLIDING	LLMBK.45LS	LLMDK.45LS
45° RIGHT SLIDING	LLMBK.45RS	LLMDK.45RS
90° CENTER SLIDING	LLMBK.90S	LLMDK.90S



No.	Description	Material	Qty
1	1/4" -20 Locknut	Stainless Steel Nylon-Insert	2
2	Washer, 1/4" screw size, 0.75" OD	Stainless Steel	4
3	Link & Lock Mounting Clip	Nylon w. Stainless Washer	2
4	Isolation Washer for 1/4" screw size	Nylon, Black	2
5	Plastic Washer, 1/4" screw size, 0.734 OD	Nylon, Black	2
6	1/4" -20 Socket Head Screw, 1-1/2" length	Stainless Steel	2
7	Link & Lock Bracket -90 Center Sliding	6005A Aluminum	1

L&L Bracket Dimensions

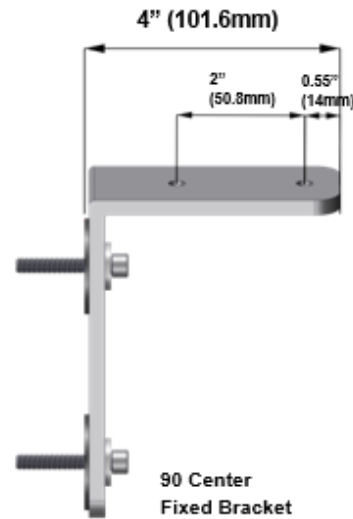
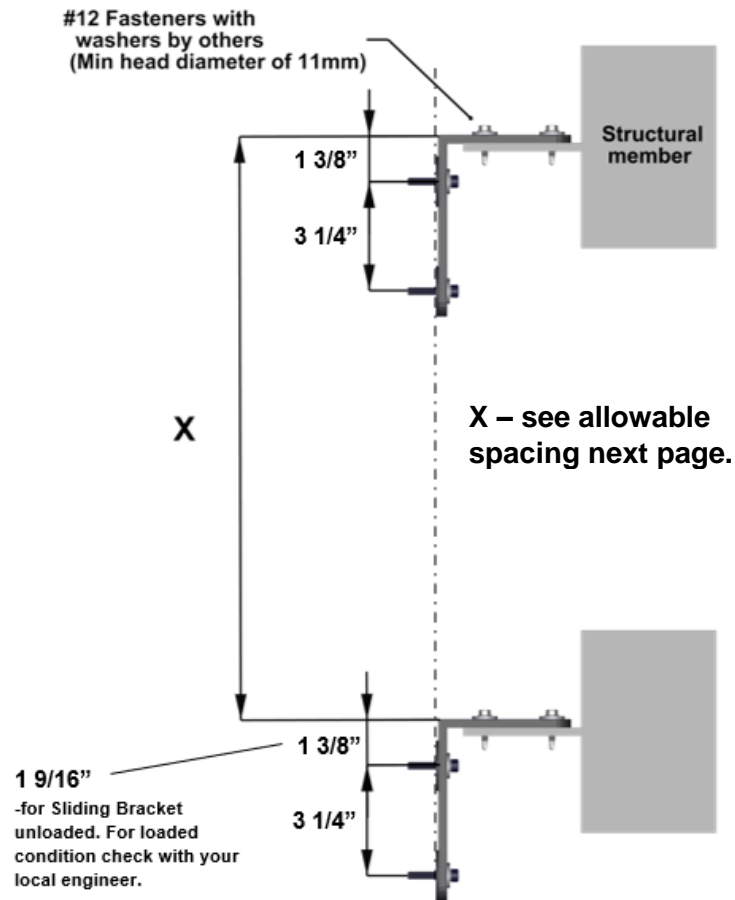

Tools for Bracket Install to L&L



7/16" Nut Driver
Fixed & Sliding
Brackets



3/16" Allen Key
Fixed & Sliding
Brackets

L&L Bracket Installation, Load Data & Allowable Spacing

See [L&L Install Guide](#) for details

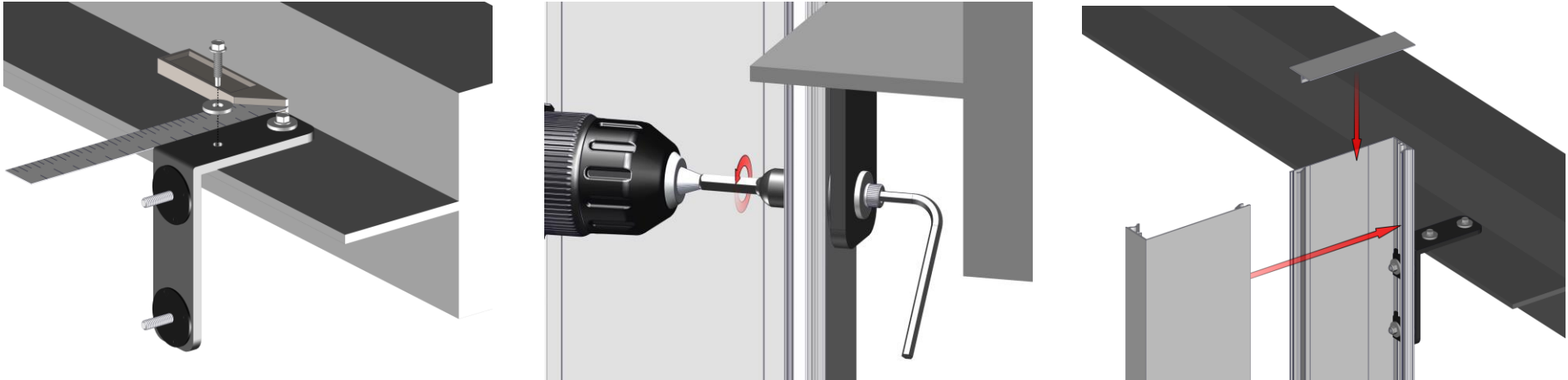

LINK & LOCK™ BATTEN	LINK & LOCK™ BRACKET MAX. SPACING (FT)									
	WIND LOAD PSF (FACTORED/ULTIMATE)									
	30	40	50	60	70	80	90	100	110	120
1-5/8" x 2"	10'	8'	6'	6'	4'	4'	2'	2'	2'	2'
1-5/8" x 4"	8'	6'	4'	4'	2'	2'	2'	2'	2'	2'
1-5/8" x 4" w. Internal Stiffener	12'	10'	8'	6'	6'	4'	4'	4'	4'	4'
1-5/8" x 6"	6'	4'	4'	3'	3'	3'	2'	2'	2'	2'
1-5/8" x 6" w. Internal Stiffener	10'	8'	6'	4'	4'	3'	3'	3'	2'	2'
1-5/8" x 8"	6'	4'	2'	2'	2'	2'	2'	2'	2'	2'
1-5/8" x 8" w. Internal Stiffener	8'	6'	4'	4'	3'	3'	2'	2'	2'	2'
2" x 4" HD	12'	10'	8'	6'	6'	4'	4'	4'	4'	4'
2" x 6" HD	10'	8'	6'	4'	4'	3'	3'	3'	3'	3'
2" x 8" HD	8'	6'	4'	4'	3'	3'	2'	2'	2'	2'

Recommended torque value for Link & Lock™ to Bracket attachment:

note 1 Factored Wind Load: max. 168 LBS/EA Bracket

note 2 Factored Dead Load: max. 29 LBS/EA Fixed Bracket

note 3 Fixed Bracket 1/4" -20 Socket Head Screw, 60-72 in/lbs + prevailing torque of self-locking nut

note 4 Sliding Bracket 1/4" -20 Socket Head Screw, 48-60 in/lbs + prevailing torque of self-locking nut

April 25, 2024



LONGBOARD®
INSPIRING ARCHITECTURE

Link & Lock™ Cladding

Installation Guidelines

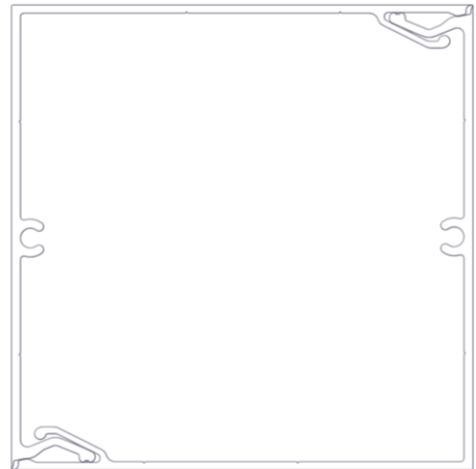
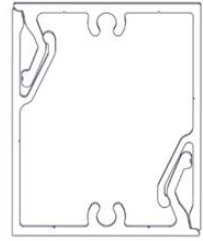
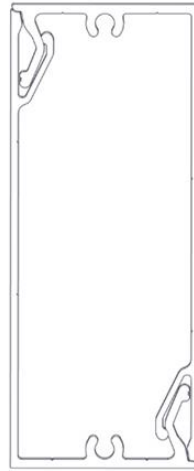
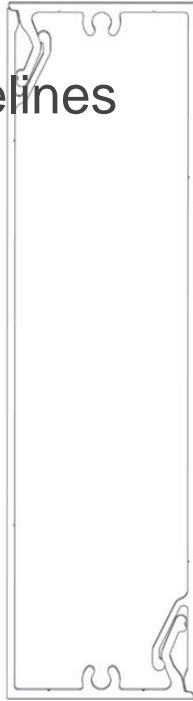

Table of Contents

Material Specifications	3
Finishes	3
Expansion and contraction	3
Material ordering and deliveries	3
Storage and handling	3
Cleaning	3
Warranty	3
Graffiti Removal	4
Components	5
Components (Typical)	5
Tools/Cutting/Fastening	6
Tools	6
Cutting	6
Fastening	7
Fastener types	7
Framing requirements	8
System Install	9
Install details	9
Typical dimensions	9
System layout and Install steps	10
Perimeter and field area limitations	10
Cantilever limits	10
Preparation drilling for Install	11
Butt-Joints & Lap Joints	12
Batten orientation	13-14
Fin orientation	15
End to End orientation	16-17
Large spans with Stiffener	18-20
Link & Lock HD	21
4x4 & 4x6 Link & Lock	22
Link & Lock Brackets	23-27
Appendix	28
Tables 1 & 2 - Expansion & contraction	28
Tables 3-9 - Allowable Attachment Span	29-34
Handling and care of products	35
Contact Info	36

Material Specifications

Finishes

- Longboard Products are available in a wide range of powder coated finishes
- Custom solid colors are available upon request

Longboard extruded products are produced 1" (25mm) oversized, as one end is drilled for the coating process and both ends have 1/2" (12mm) of masking tape (woodgrains only) which must be cut off for best results.

Expansion & Contraction

Link & Lock components expand & contract 1/4" (6mm) over 24' (7.3m) along the length, measured over a 30°C (54°F) temperature range. Due to this range of movement, Link & Lock Fins/Louvers/Battens should be installed with staggered butt-joints, leaving a 1/4" (6mm) min. gap, every 24' (7.3m) min. Alternatively, staggered lap-joints are an option for a continuous appearance, however 1/4" (6mm) gaps should be left at each joint to allow for thermal movement. Be sure to lap joints by 2' (610mm) minimum over the back "L". See **Appendix for Tables 1 & 2, expansion/contraction calculations per foot/meter of material.**

Material Ordering & Delivery

-
- **Packaging:** Link & Lock is sold by the set (pair) and in widths of 2", 4", 6", 8"
End caps are sold by the box: 20 caps/bx
End Mounts are sold by the box: 20 mounts/bx
Stiffener is sold in 24' lengths (includes Double-sided Tape)
-
- **Ship/Receiving:** Most Popular Finishes -ready to ship within 1 week
Additional Finishes -ready to ship within 14 weeks
Delivered on 24' (7.3m) long skids weighing up to 2000 lbs. A mechanical lift with forks is required on site to receive the order.
-
- **QC:** Always inspect the delivery for damage and contact LB ASAP if there are any issues: info@longboardproducts.com or 1-800-604-0343 and include your PO# and any pictures if possible. Mark the delivery receipt as "damaged" and accept the delivery as-is. Longboard is not responsible for the installation of blemished or damaged material.

Storage & Handling

Be sure to store the material flat, keep it dry, safe & secure and remain in unopened cartons until ready to be installed. See **Appendix for proper handling and care instructions.**

Cleaning Recommendations

- Initial and periodic cleaning for best looking product
- Basic methods use a combination of moderate water pressure, soft sponge/brush and a mild detergent (Safe for your hands, safe for the product)

⚠ NEVER use aggressive, acid or alkaline cleaners on Longboard finishes. Do not use cleaners containing Trisodium Phosphate, Phosphoric Acid, Hydrochloric Acid, Hydrofluoric Acid, Fluorides, or any other compound that is known to react with metal.

***See Cleaning Guide for full requirements & cleaning schedule:**
longboardproducts/resources/care-maintenance.com

Warranty

Upon substantial completion of the project, register for warranty online here: longboardproducts.com/warranty

⚠ Registration is required for the warranty to be in effect.

Graffiti Removal

Standard Woodgrain
 Use Standard soap & water only

D2000 Solid Color

	Prosoco Cleaner	MEK Solvent
Permanent Marker	<input checked="" type="checkbox"/>	<input checked="" type="checkbox"/>
Oil Based Spray Paint	<input checked="" type="checkbox"/>	<input checked="" type="checkbox"/>
Water Based Spray Paint	<input checked="" type="checkbox"/>	<input checked="" type="checkbox"/>
Adhesive Tape	<input checked="" type="checkbox"/>	<input checked="" type="checkbox"/>

MEK Solvent

Prosoco Anti-Graffiti Cleaner

SPECIAL ORDER - EXT. LEAD TIMES CONTACT LB

Anti-Graffiti High Gloss Woodgrain

	MEK Solvent
Permanent Marker	<input checked="" type="checkbox"/>
Oil Based Spray Paint	<input checked="" type="checkbox"/>
Water Based Spray Paint	<input checked="" type="checkbox"/>
Adhesive Tape	<input checked="" type="checkbox"/>

MEK Solvent

Note: Cleaning the surface with a cleanser that is not diluted as per instructions may result in damage to the coating.

Components

Components (Typical)

The Link & Lock™ system consists of two (2) matching L-shaped extrusions, snapped together to make a complete set. For all LB components go to longboardproducts.com.

Link & Lock™ Battens

Size	12'	24'	End Caps (20/box)	End Mounts (20/box)
2"	2X2LL.145	2X2LL.289	2LLEC.2	2LLEM.2
4"	2X4LL.145	2X4LL.289	2LLEC.4	2LLEM.4
6"	2X6LL.145	2X6LL.289	2LLEC.6	2LLEM.6
8"	2X8LL.145	2X8LL.289	2LLEC.8	2LLEM.8

Link & Lock™ HD Battens

4"	2X4LLHD.145	2X4LLHD.289	2LLHDEC.4	2LLHDEM.4
6"	2X6LLHD.145	2X6LLHD.289	2LLHDEC.6	2LLHDEM.6
8"	2X8LLHD.145	2X8LLHD.289	2LLHDEC.8	2LLHDEM.8

Link & Lock™ Box Battens

4 x 4"	4X4LL.145	4X4LL.289	4LLEC.4	-
4 x 6"	4X6LL.145	4X6LL.289	4LLEC.6	-



Mounting Accessories	Qty	SKU
Link & Lock Mounting Clip	48, bag	LLMC.N48
Link & Lock™ Isolation Washer	48, bag	FAST.5003.BOX48
Dewalt® 1/2" Pilot Point Drill Bit	1	DRILLBT.05
24' Link & Lock Internal Stiffener	1	LLSTIFF.289
3M® Double Sided Adhesive Tape - 108'	1, roll	LLTAPE.1296



Link & Lock™ Mounting Brackets







Product	Single	Dual
45° LEFT FIXED	LLMBK.45LF	LLMDK.45LF
45° RIGHT FIXED	LLMBK.45RF	LLMDK.45RF
90° CENTER FIXED	LLMBK.90F	LLMDK.90F
45° LEFT SLIDING	LLMBK.45LS	LLMDK.45LS
45° RIGHT SLIDING	LLMBK.45RS	LLMDK.45RS
90° CENTER SLIDING	LLMBK.90S	LLMDK.90S

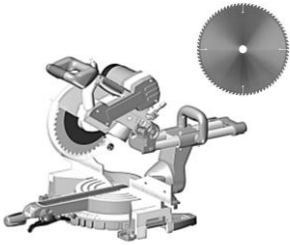

Tools/Cutting/Fastening

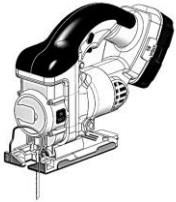
Tools

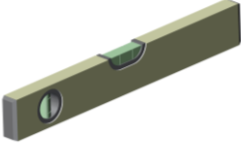
Commonly used tools for Link & Lock install.

			
Table Saw with Carbide Metal Blade Non-ferrous 60-80T (for cutting aluminum)	Miter Saw with Carbide Metal Blade Non-ferrous 60-80T (for cutting aluminum)	Cordless Drill with clutch	Jig Saw (for protrusions)
			
Rubber Mallet (or Hammer)	Level	Hole Saw (for lighting fixtures)	Quick Grip Bar Clamp

Cutting

⚠ Always be sure to wear appropriate PPE: eye & hearing protection.

Cut battens using a Miter Saw and Table Saw always allowing for expansion & contraction. Trim the taped/drilled ends of all stock length material by at least **1/2" (12mm) each end** and discard.



⚠ DO NOT Install Link & Lock without trimming the ends.

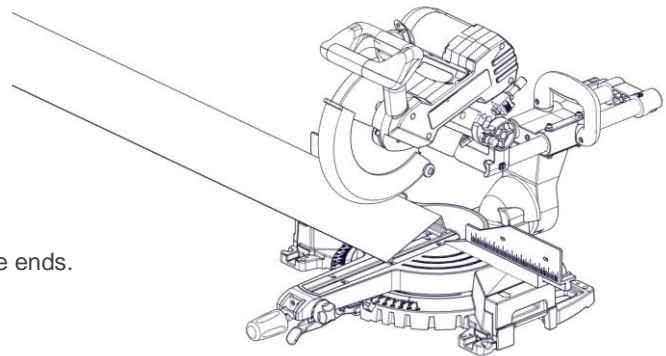

Fastening

Longboard Link & Lock™ consists of two (2) matching L-shaped extrusions, snapped together to make a complete set. The back “L” is mechanically fastened to the substrate, using Longboard **Mounting Clips and Isolation Washers** fastened every **6-8’ O.C. up to 12ft when using Stiffeners** with #12 (#14 for L&L HD) sharp-point screws (for wood substrates) or self-drilling (for metal substrates). The Mounting Clips and Isolation Washers are included in the order for 6’ spacings.

Fasteners must be corrosion resistant and comply with all local building codes.

⚠ All fasteners should be suitable for exterior use and be compatible with the substrate type. **Fasteners should be anchored into a solid secure substrate.**

Layout and predrill the back “L” at all fastener locations.
Refer to **Preparation drilling for Install** for hole dimensions and further details.

⚠ See **Appendix for project specific fastener spacing:**
Allowable Span - Tables 3-9

Fastener Types/Sizes for L&L		
L&L	Pan Head	Hex Head
2”	#12	#12
4”	#12	#12
6”	#12	#12
8”	#12	#12
4”x4”	#12	#12
4”x6”	#12	#12
4” HD	#14	#14
6” HD	#14	#14
8” HD	#14	#14

Fastener types

RECOMMENDED

Pan-Head Rounded-Head Self-Drilling Flanged Hex Head



*Length, thread and point to suit substrate and material surface.

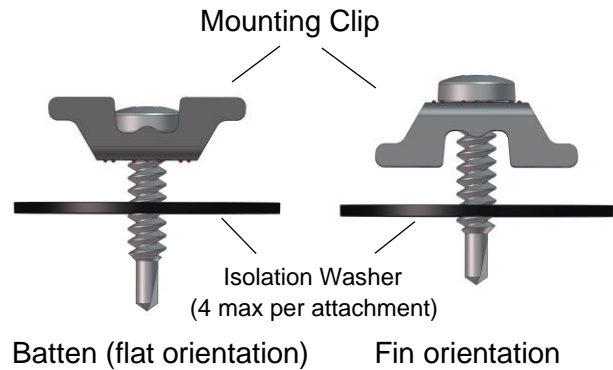

DO NOT USE

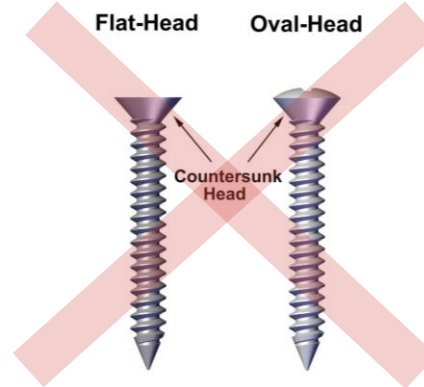

Fastener Types/Sizes for End Mounts		
End Mount	Pan Head	Hex Head
2"	#10	X
4"	#12	#12
6"	#12	#12
8"	#12	#12
4" HD	#14	#14
6" HD	#14	#14
8" HD	#14	#14

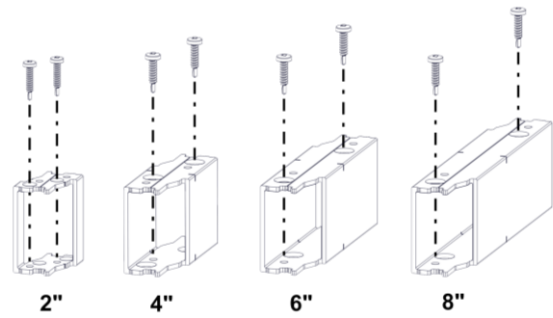

Framing/Furring requirements

Always consult your local building authority and follow local building code requirements. See Typical dimensions for sizes and weights of the L&L system.

See **Appendix for framing/furring/sheathing specs: Tables 3-9**

System Install

Install details

Typical dimensions

- Longboard Link & Lock system typical dimensions:

L&L	Width	Depth	Length	Weight(lbs/LF) *per set
2"	2" (50.8mm)	1 5/8" (41.3mm)	12'/24'	0.93
4"	4" (101.6mm)	1 5/8" (41.3mm)	12'/24'	1.3
6"	6" (152.4mm)	1 5/8" (41.3mm)	12'/24'	1.6
8"	8" (203mm)	1 5/8" (41.3mm)	12'/24'	1.9
4"x4"	4" (101.6mm)	4" (101.6mm)	12'/24'	1.8
4"x6"	6" (152.4mm)	4" (101.6mm)	12'/24'	2.1
4" HD	4" (101.6mm)	2" (50.8mm)	12'/24'	1.7
6" HD	6" (152.4mm)	2" (50.8mm)	12'/24'	2.4
8" HD	8" (203mm)	2" (50.8mm)	12'/24'	3

- Longboard Products are not recommended for use on marine applications in direct contact with salt water.
- Link & Lock is an open-joint system which is required to be installed outboard of a weather resistant barrier, including all flashings, following code, and building requirements.
- It is good practice to leave a 1/4" (6mm) gap between every component joint or 24' (7.3m) to allow for expansion & contraction. Consider the joints where components meet each other to dictate which component is installed first (eg: right angle butt joints, mitered joints etc.).
- Mounting Clips and Isolation Washers allow for movement of the battens, to expand & contract during thermal changes.
- Fasten Mounting Clips every 6-8' typical (based on project wind load requirements), alternating from top to bottom for battens using die lines for guides.

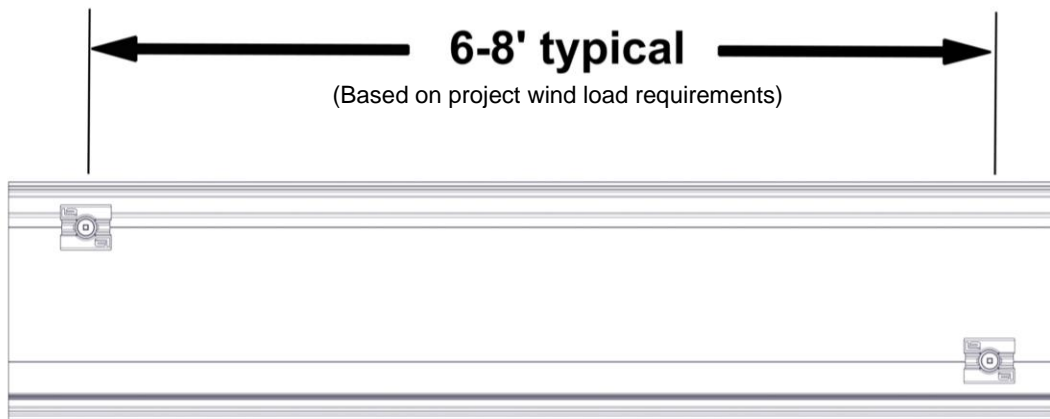

System layout and Install steps

Perimeter and field area limitations

Measure and layout your wall area to consider Link & Lock alignment with fixtures, penetrations, and adjacent walls, for desired appearance. The same methodology applies for vertical installations.

Seamless runs up to 24' length battens (no butt-joints)

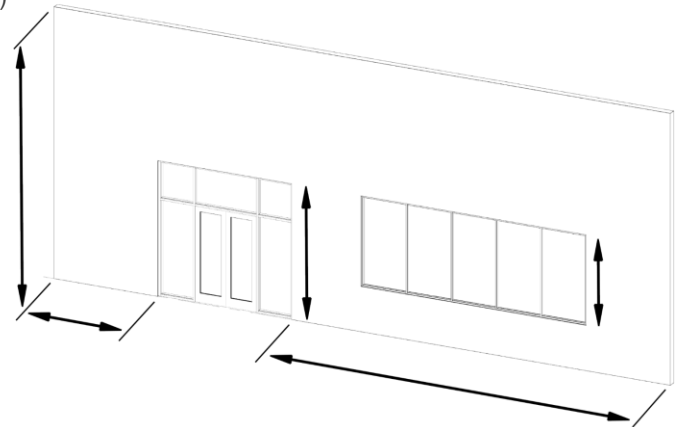
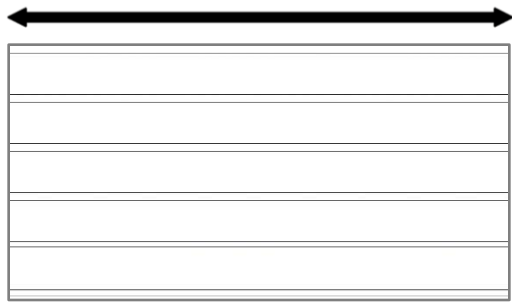

Runs with staggered butt-joints

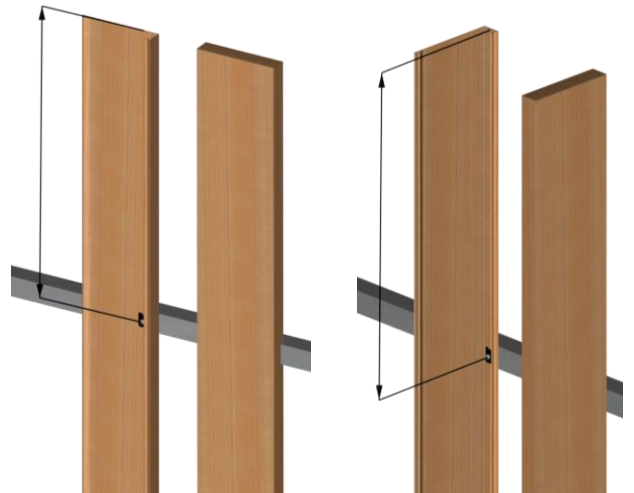
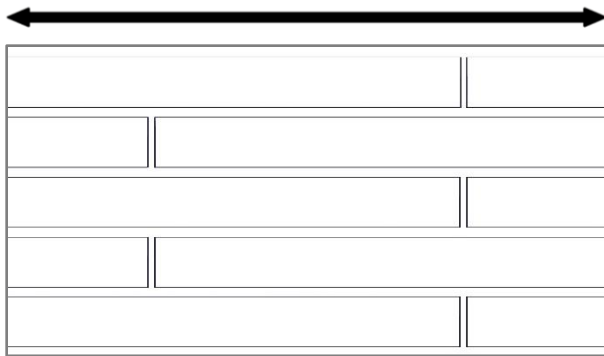

Runs with staggered lap-joints.

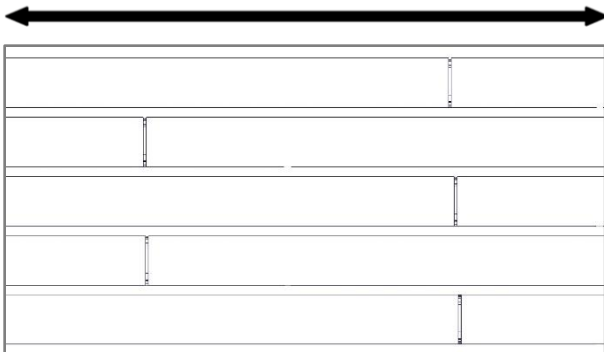

Link & Lock can cantilever half the allowable attachment span up to a **maximum of 3'** for all sizes and orientation. See Appendix for allowable attachment span:
Tables 3-9

Preparation drilling for Install

To prepare Link & Lock for install, layout and predrill the back "L" with 1/2" holes every 6-8' O.C. typical, with the first hole 2" in from the end to allow space for the End Cap.

For the Batten orientation, alternate the holes from top to bottom using the Dielines for guides.

For Fin orientation, use Pilot Point Drill Bit (see below) as recommended for ease of drilling.

Note: To hard fasten 1 location per length, omit the drilled hole at that location and use for hard fastening.

See **Appendix for project specific fastener spacing:**

Allowable Span - Tables 3-9

⚠ Tip: Add weep holes as good practice to allow any potential moisture to escape.

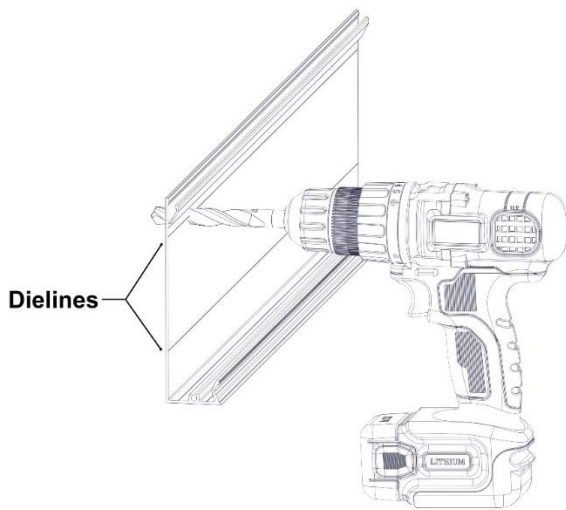
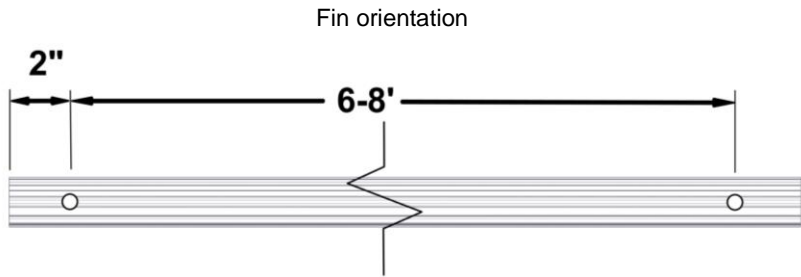
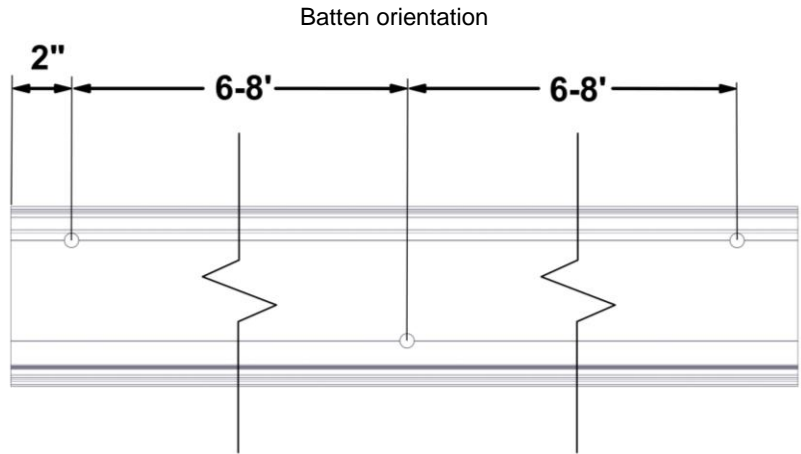

Back "L"

1/2" Pilot Point Drill Bit

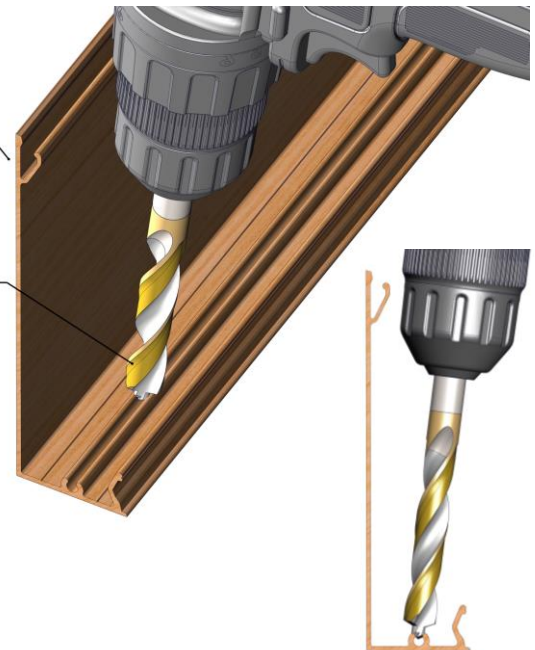

Butt-Joints & Lap Joints

- **⚠ BUTT-JOINTS.** When installing butt-joints, ensure to leave a 1/4" (6mm) min. gap. every 24' (7.3m) min. (See **Detail A**). Fasteners should be anchored into a solid secure framing member, blocking, furring strip, or backer plate, etc.
- **⚠ LAP-JOINTS.** When installing lap-joints, ensure to leave a 1/4" (6mm) min. gap. every 24' (7.3m) min. (See **Detail A**). Fasteners should be anchored into a solid secure framing member, blocking, furring strip, or backer plate, etc.
- If needed, use touch-up paint pens (purchased separately) to finish the ends at the butt-joint or lap-joint.
- It is good practice to hard-fasten each back "L" at one point per length typically near the center, to keep the battens from migrating.
- DO NOT hard-fasten more than one (1) location per batten.

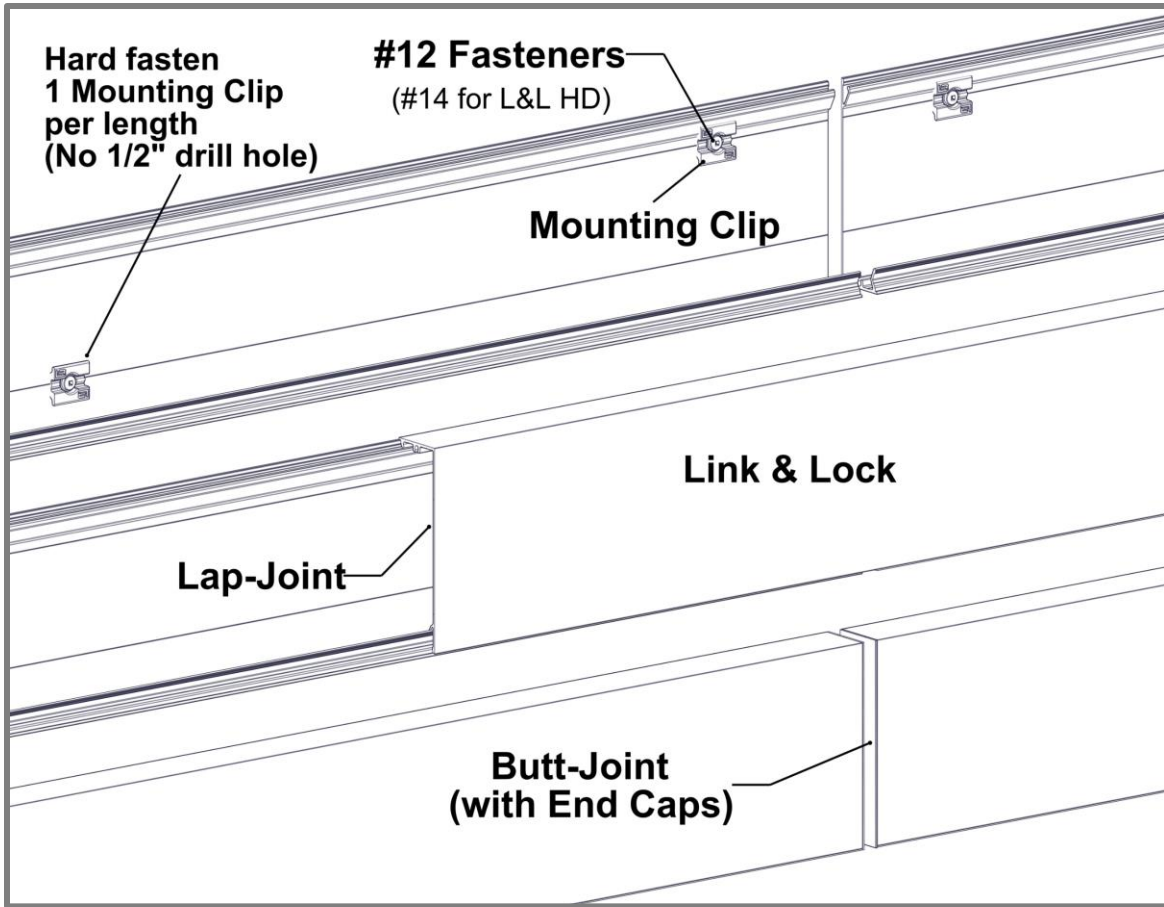

Detail A

Install Batten orientation

Step 1

Place predrilled Link & Lock back "L" into position (Drilling page 11). It is good practice to check your installation every 2-3 rows for level/plumb and flat/straight, for best results.

 **Cut off Taped/Drilled L&L ends (1/2" each end).**

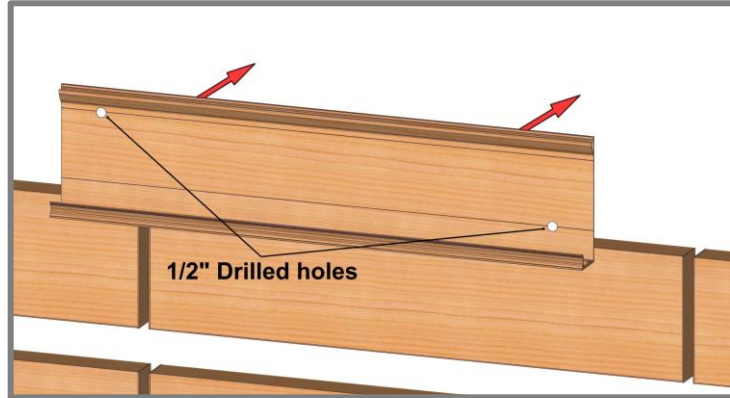

Step 2

Install back "L" using #12 Fasteners (#14 for L&L HD), Mounting Clips and Isolation Washers every 6-8' O.C. typical. Isolation Washers are installed between the L&L and the substrate (4 max per attachment).

Note: Be sure to fasten in the center of the 1/2" holes to allow for movement each way. Hard fasten near the center of each length to prevent migration of the material over time.

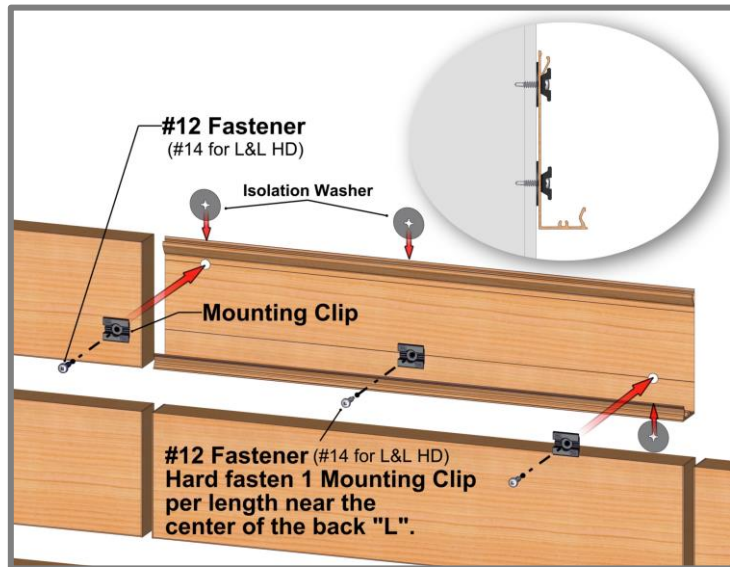

Step 3

Install front "L" and snap it into place, aligning it with ends and joints. If necessary, use a rubber mallet or hammer and block to protect the finish.

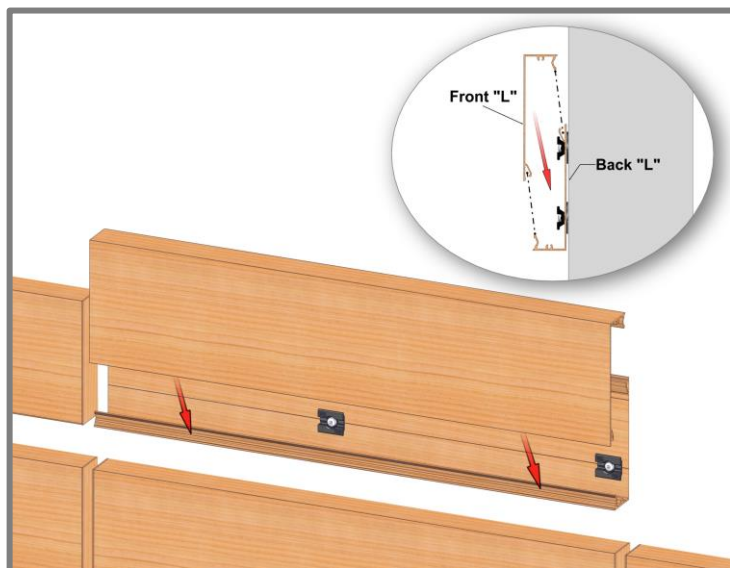

Step 3.1

Use clamps with rubber pads as common practice to securely snap the front "L" onto the back "L".

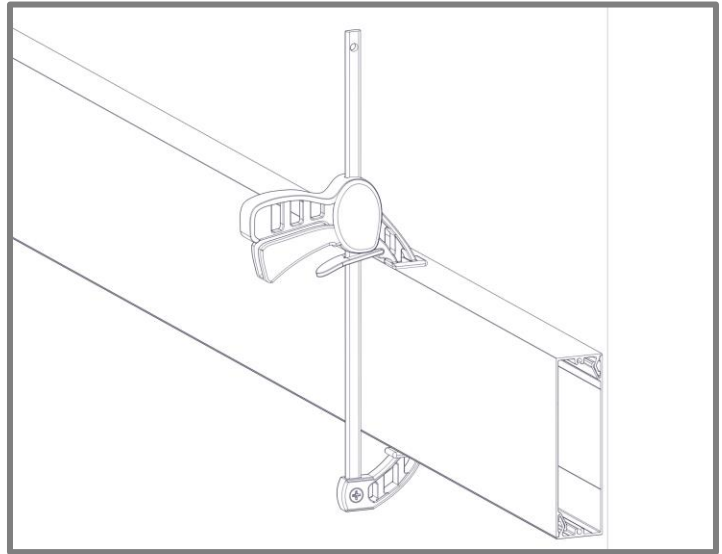

Step 4

Install End Caps, which are friction fit, by pressing them into place using the palm of your hand. If necessary, use a rubber mallet to snap them into place. See below images. Use paint pens to coat Link & Lock cut ends that may show slightly beyond the End Caps.

Consider your application sequence of the End Caps before installing adjacent Link & Lock members, as they may limit the space needed to insert the caps. In this situation you may need to install the caps first then the front "L" as seen in the image to the right.

▲ TIP: Use shim to hold/secure cap while snapping in the front "L".

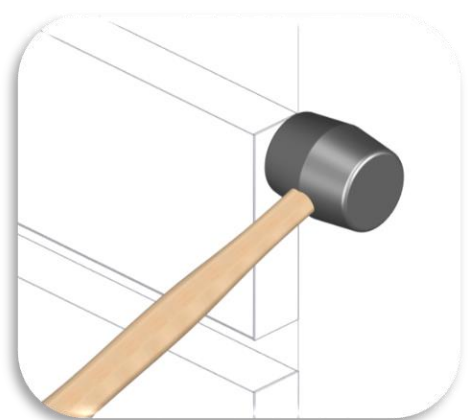
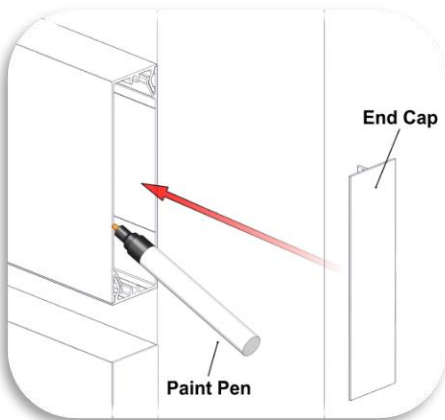
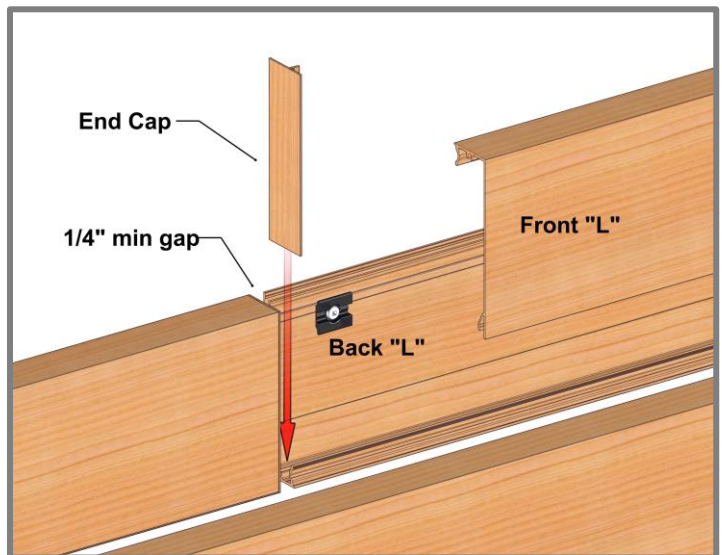

Install Fin orientation

Step 1

Place predrilled Link & Lock back “L” into position (Drilling page 11). It is good practice to check your installation every 2-3 rows for level/plumb and flat/straight, for best results.

Cut off Taped/Drilled L&L ends (1/2" each end).

Fin Orientation

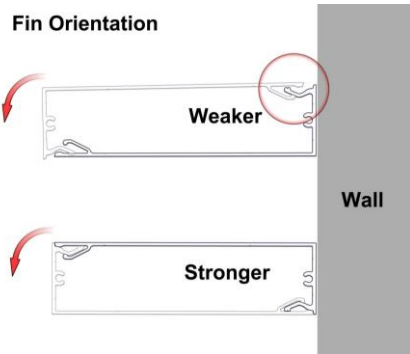

Step 2

Install back “L” using #12 Fasteners (#14 for L&L HD), Mounting Clips and Isolation Washers every 6-8' O.C. typical. Isolation Washers are installed between the L&L and the substrate (4 max per attachment).

Note: Be sure to fasten in the center of the 1/2" holes to allow for movement each way. Hard fasten near the center of each length to prevent migration of the material over time.

Step 3

Install front “L” and snap it into place, aligning it with ends and joints. If necessary, use a rubber mallet or hammer and block to protect the finish.

Step 4

Refer to Page 14 for End Cap install and considerations.

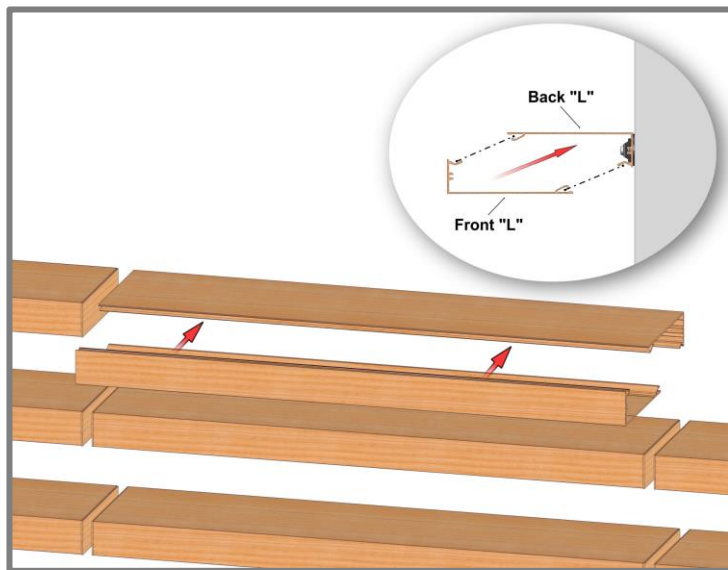
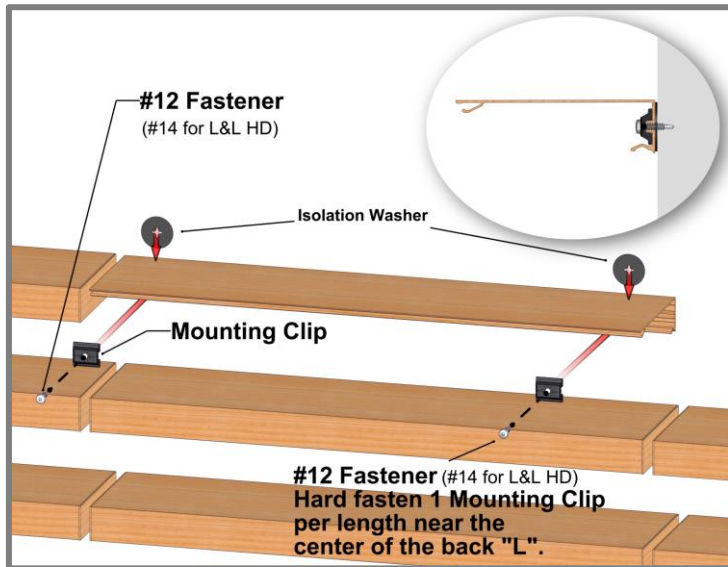
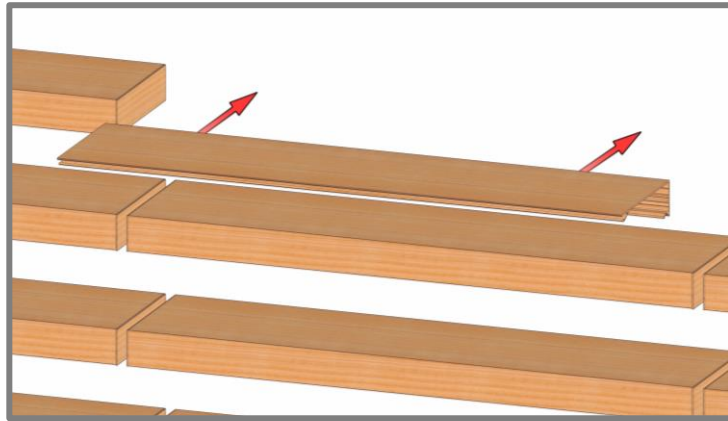

Install End to End orientation

Note: Use Tables 3-9 in Appendix for Allowable Span for Wind Loading.

Step 1

Place End Mounts into position at the top and bottom of the install. It is good practice to check your installation every 2-3 rows for level/plumb and flat/straight, for best results.

Fastener Types for End Mounts		
End Mount	Pan Head	Hex Head
2"	#10	
4"	#12	#12
6"	#12	#12
8"	#12	#12
4" HD	#14	#14
6" HD	#14	#14
8" HD	#14	#14

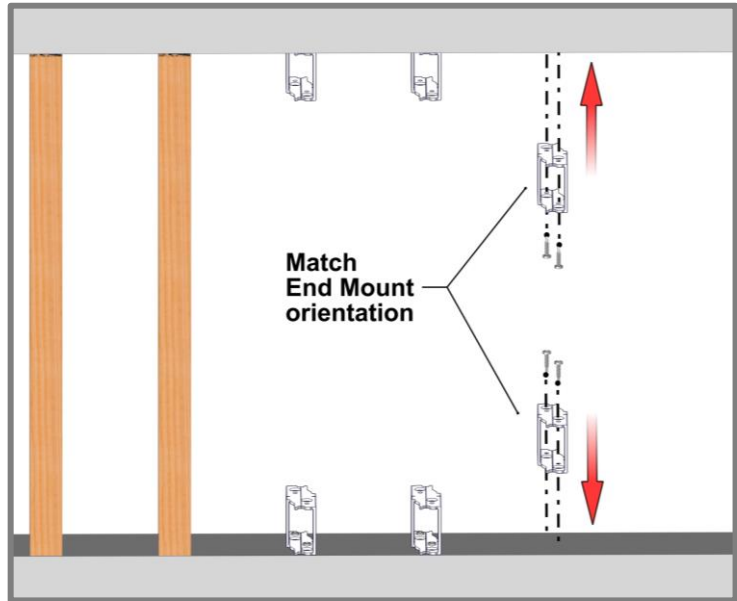

Step 2

Install the End Mounts using Fasteners (by others). Make sure to match the orientation of the End Mounts so the Link & Lock set matches on the top and the bottom. See above for **Fastener Types and sizing for End Mounts**.

▲ TIP: Check the position of the End Mounts once installed to allow a plumb and straight look.

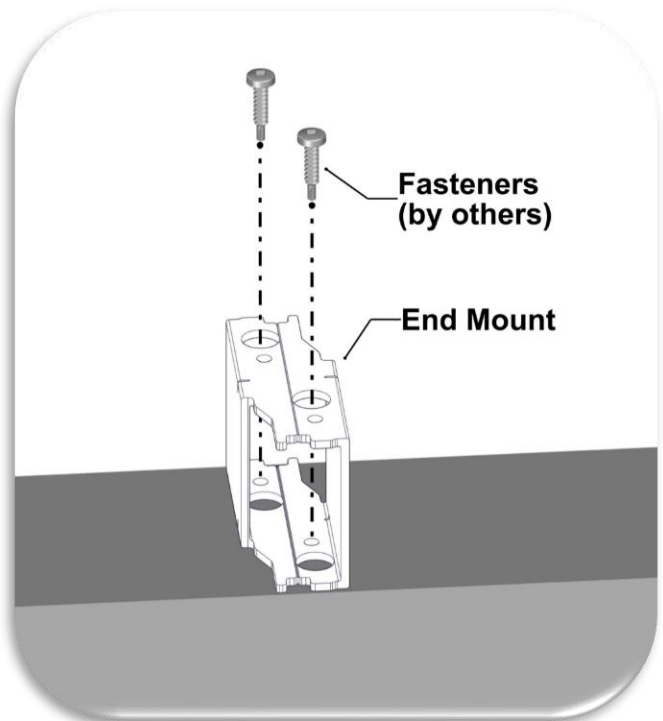
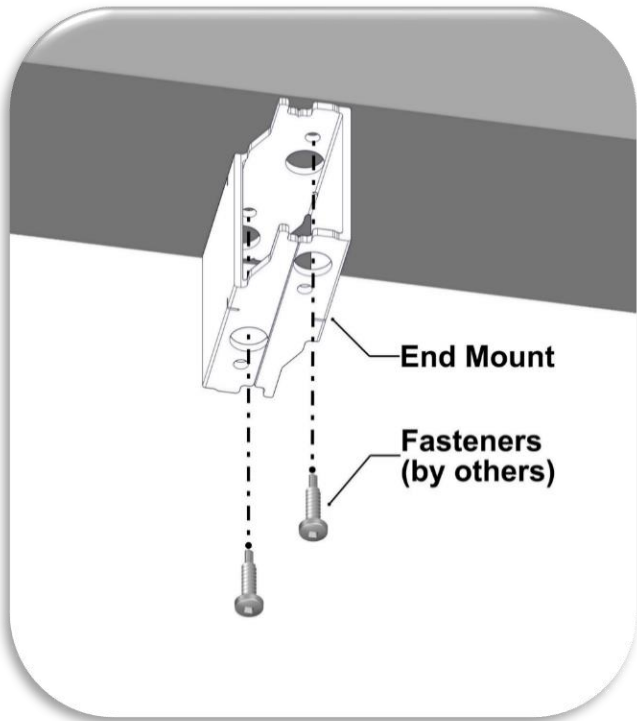

Step 3

Measure, cut and install Link & Lock Set and snap it into place onto the End Mounts. Use clamps with rubber pads as common practice to securely snap the front “L” onto the back “L”. If necessary, use a rubber mallet or hammer and block to protect the finish.

⚠ TIP: When measuring the Link & Lock, make sure to leave a gap (~1/4”) for expansion and building movement.

⚠ Cut off Taped/Drilled L&L ends (1/2" each end).

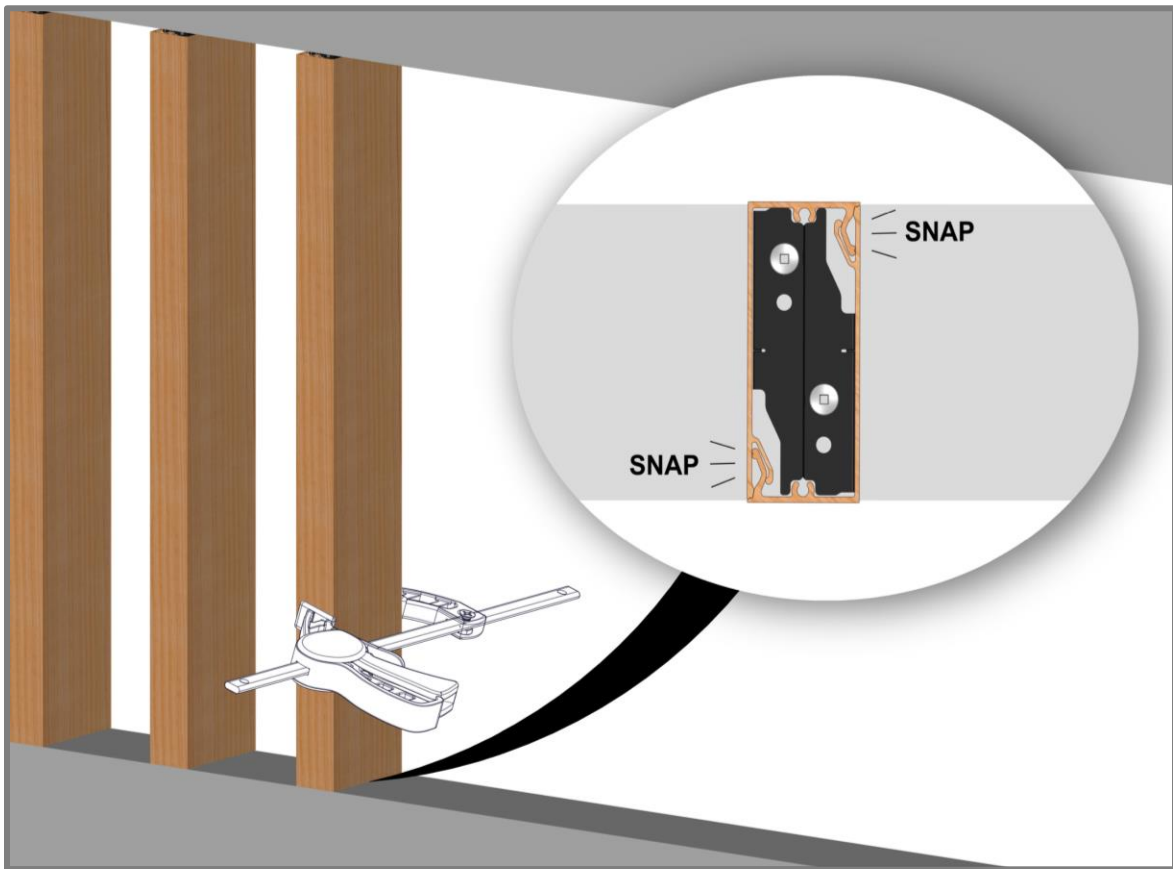
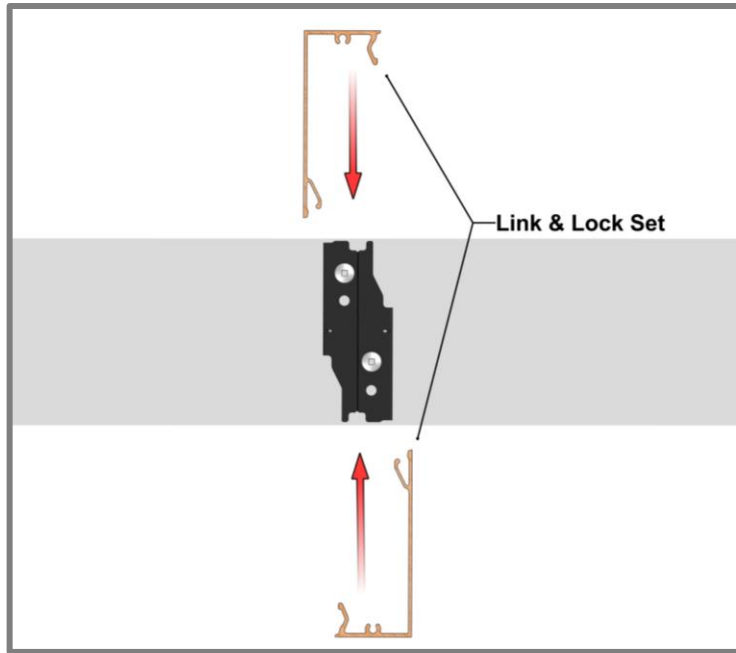
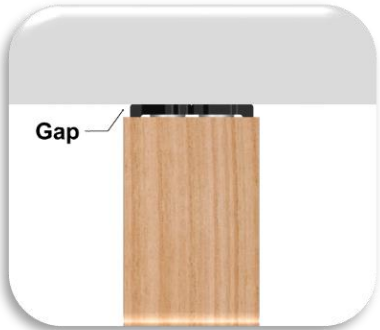

Large spans with Internal Stiffener

Requirements for large spans:

- Two Mounting Clips with #12 fasteners min, (#14 for L&L HD) are used at both ends with a minimum distance apart of 5" O.C.
- An Internal Stiffener is added to reinforce the Link & Lock set for spans up to 12' max @30psf.
- Stiffener must be one continuous member from attachment to attachment.
- Double-sided Tape is used to place the Stiffener onto the Link & Lock. The tape is placed on the center of the Stiffener and then pressed onto far end of the back "L" as shown on page 19.

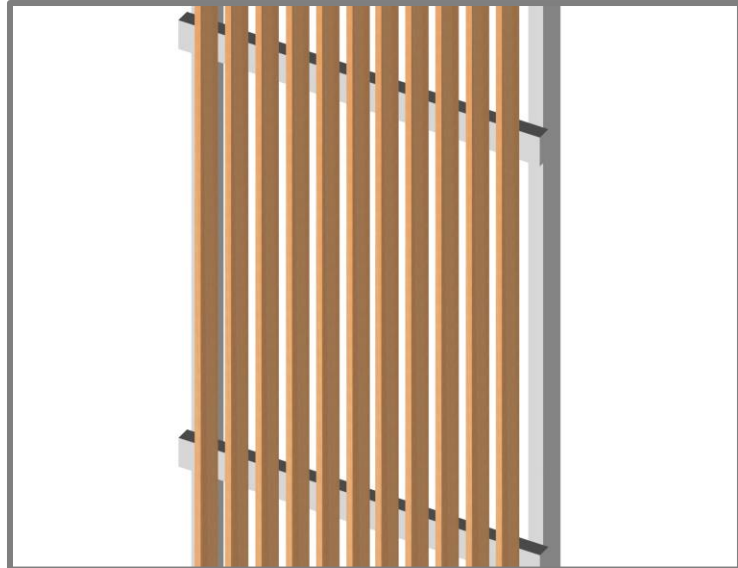

See **Appendix for allowable spans for project specific wind load.**

Allowable Span - Tables 3-6

Step 1

Place predrilled Link & Lock back "L" into position (Drilling page 11). It is good practice to check your installation every 2-3 rows for level/plumb and flat/straight, for best results.

Step 2

Install back "L" using #12 Fasteners min, (#14 for L&L HD) and Mounting Clips at end attachment points with a minimum distance apart of 5" O.C.

Note: Be sure to fasten in the center of the 1/2" holes to allow for movement each way. Hard fasten one end of each length to prevent migration of the material over time.

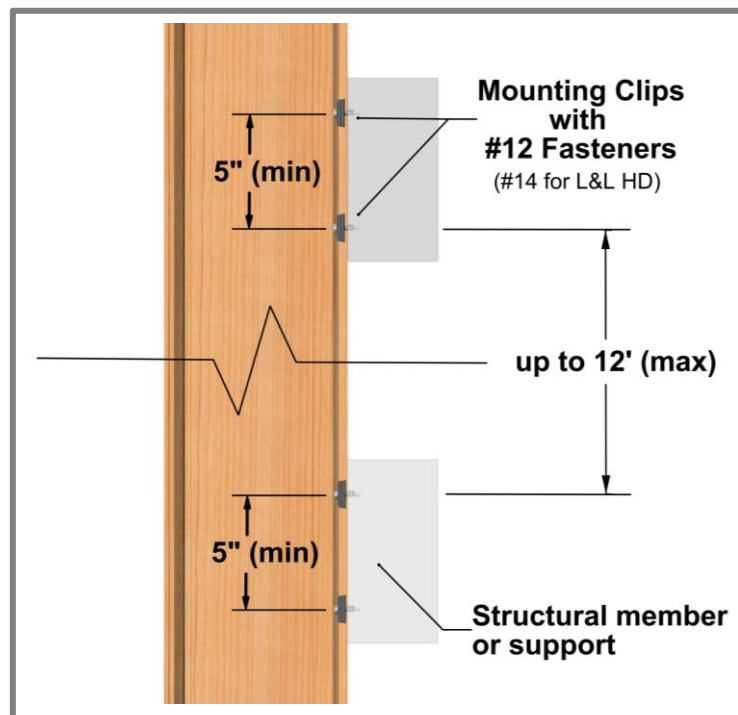

Step 3

Peel and place the Double-sided tape onto the back of the Stiffener O.C. Peel the second side and install the Stiffener as shown in the image pressing down to adhere to the tape.

Note: Install Stiffener 1" (min) from the end of the L&L to allow space for the End Cap as seen below.

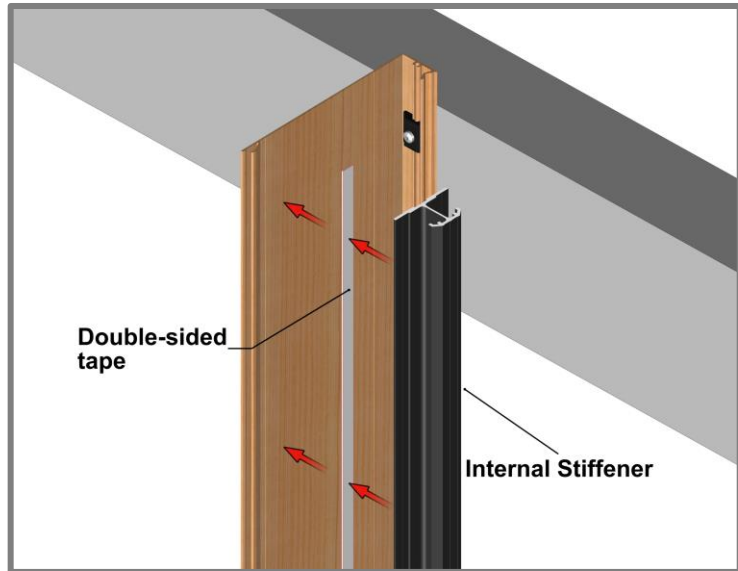

Make sure the Stiffener is located at the end of the back "L" and the tape is in the center of the stiffener.

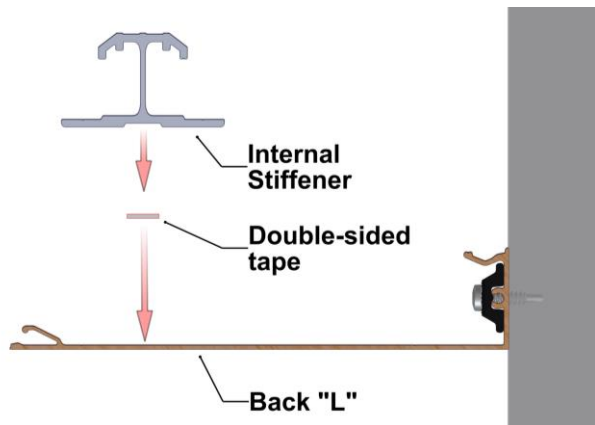

Step 4

-Fastening Stiffener in Fin orientation

Mechanically fasten the Stiffener to the back "L" using 1/8" Dome Head Rivets (Aluminum). Drill the flange of the Stiffener using a 1/8" Drill bit and fasten two Rivets at the top or one end to mitigate movement of the stiffener over time.

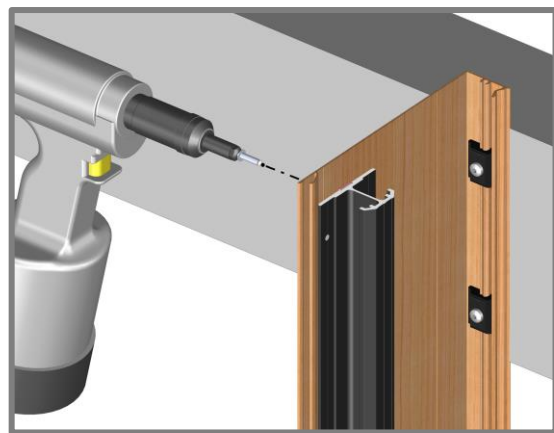

Step 4.1

-Fastening Stiffener Batten orientation
Mechanically fasten the Stiffener to the back "L" using the Mounting Clips and #12 Fasteners.

Refer to Step 2, Page 13 for mounting.

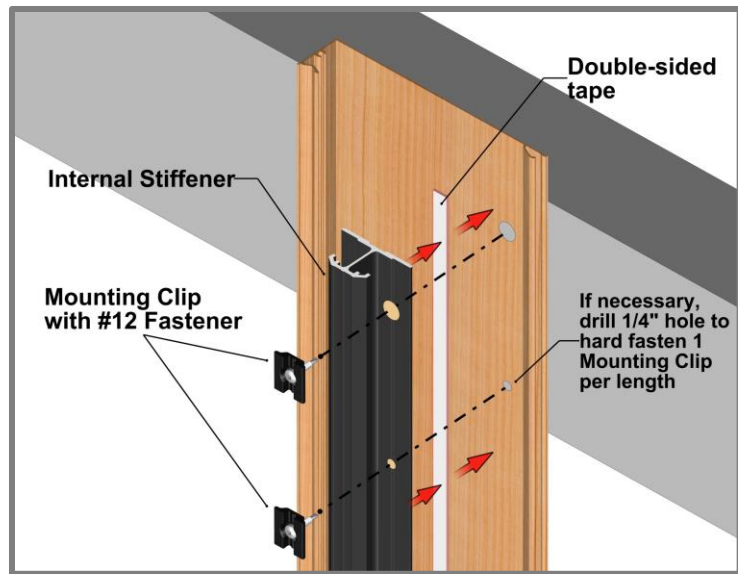

Step 5

Refer to Step 3 & 4 on Page 13-14 for Front "L" and End Cap install and details.



Link & Lock HD

- Used for greater spans compared to standard Link & Lock
- Available sizes: 4", 6" & 8" (2" depth)
- Uses standard Mounting Clip, Isolation Washer and attachment methods
- Use #14 Fasteners

Refer to System Layout and Install steps section for typical install details.

To Compare allowable spans:
See **Appendix for allowable spans for project specific wind load.**
Allowable Span – Tables 3-6

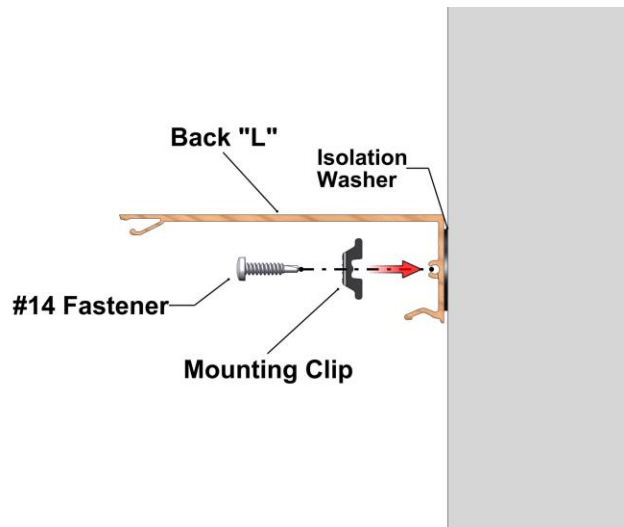

6" L&L
6' span max
@30PSF

6" L&L HD
12' span max
@30PSF

Profile Comparison

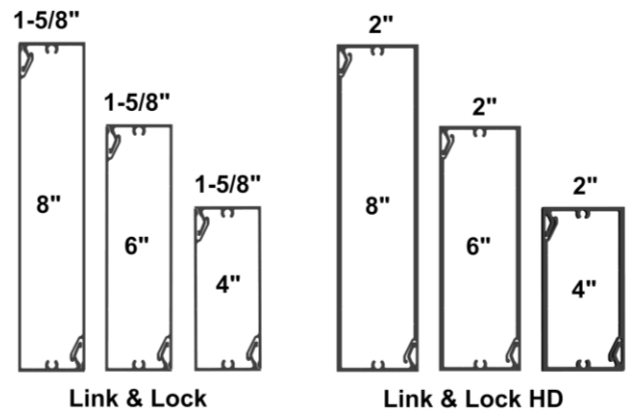

4x4 & 4x6 Link & Lock

- Available sizes: 4"x4" & 4"x6"
- Uses standard Mounting Clip and attachment methods with #12 Fasteners

Refer to System Layout and Install steps section for typical install details.

See **Appendix for allowable spans for project specific wind load.**
Allowable Span – Tables 7 & 8,
Page 33-34

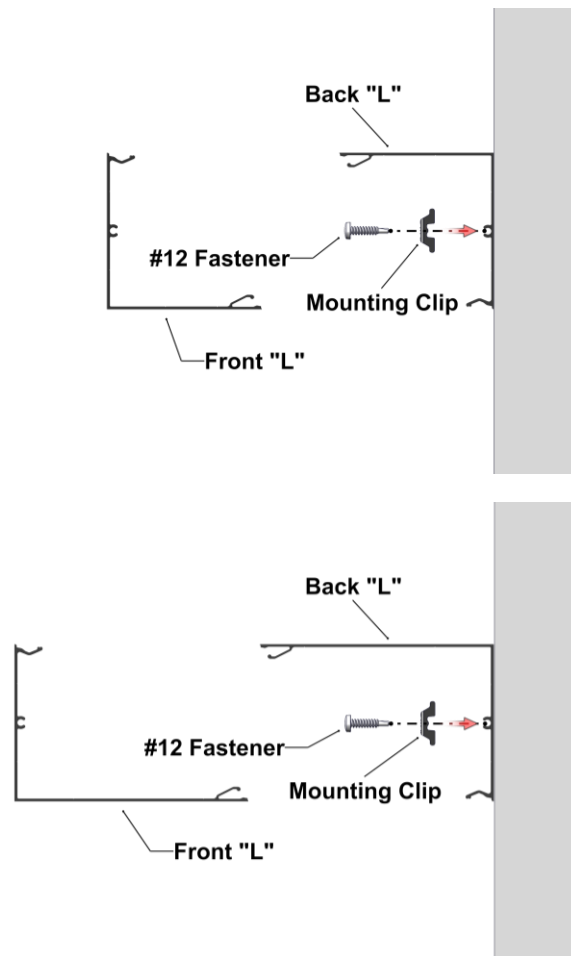

Link & Lock Brackets

- Alternate option for securing L&L cladding
- Attachment from L&L to bracket: use 1/4" Socket Head Screws, washers, locknuts & Mounting Clips included in order
- Attachment to structural element: Min #12 Fasteners (Min head diameter of 11mm) by others
- For expansion & contraction hard fasten only one fixed bracket per L&L run.
- Sliding Brackets are used for floor/slab deflection.

See **Appendix** for L&L Bracket Max. Spacing. **Table 9, Page 34**

Link & Lock Bracket Options

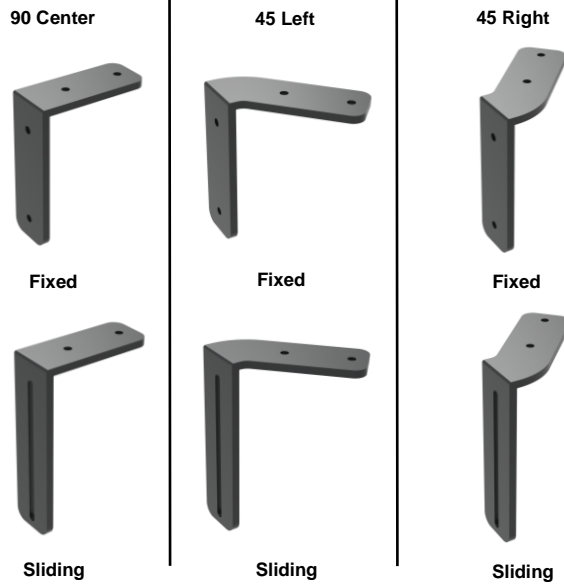

Single Bracket for horizontal substrate

Fixed Bracket (Hard fastened with 1/4" holes)

Fixed Bracket (Expansion 1/2" holes)

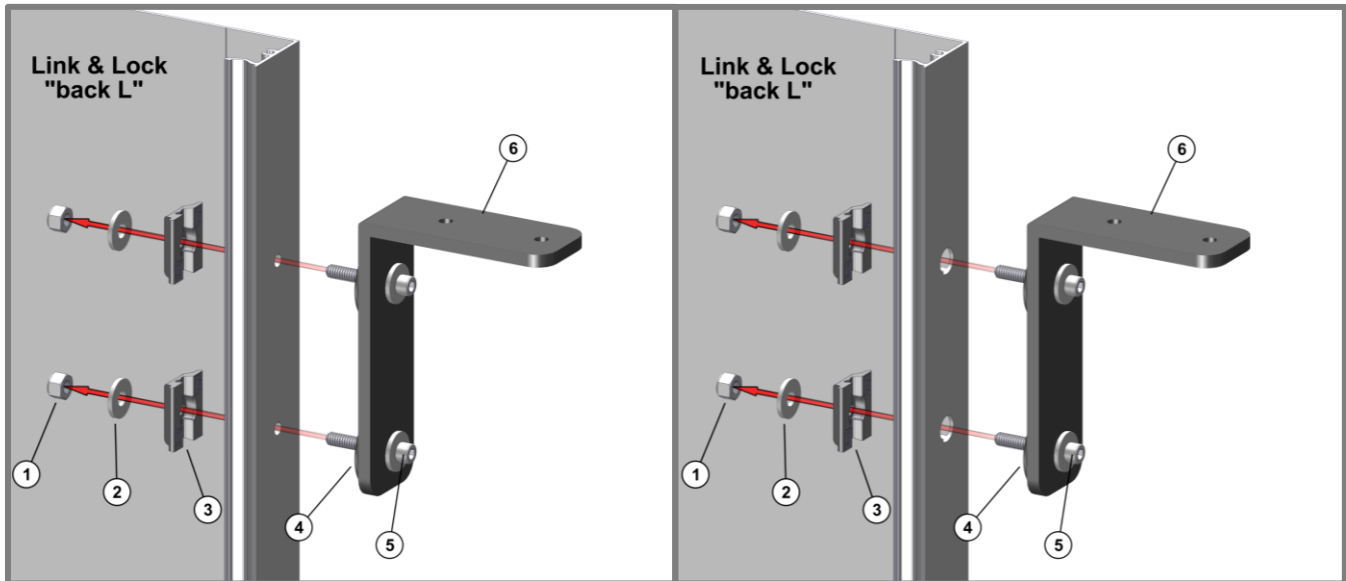

No.	Description	Material	Qty
1	1/4" -20 Locknut	Stainless Steel Nylon-Insert	2
2	Washer, 1/4" screw size, 0.75" OD	Stainless Steel	4
3	Link & Lock Mounting Clip	Nylon w. Stainless Washer	2
4	Isolation Washer for 1/4" size	Nylon, Black	2
5	1/4" -20 Socket Head Screw, 1-1/2" length	Stainless Steel	2
6	Link & Lock Bracket -90 Center Fixed	6005A Aluminum	1

Sliding Bracket (Use 1/4" holes)

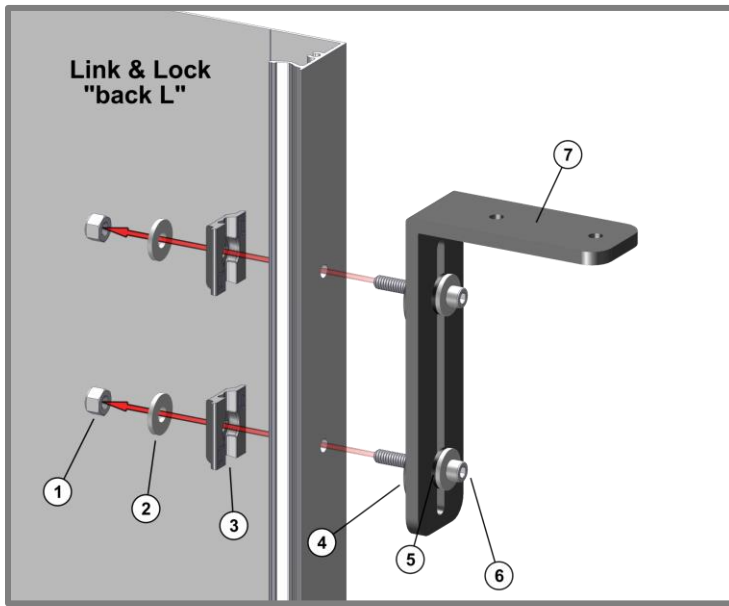

No.	Description	Material	Qty
1	1/4" -20 Locknut	Stainless Steel Nylon-Insert	2
2	Washer, 1/4" screw size, 0.75" OD	Stainless Steel	4
3	Link & Lock Mounting Clip	Nylon w. Stainless Washer	2
4	Isolation Washer for 1/4" screw size	Nylon, Black	2
5	Plastic Washer, 1/4" screw size, 0.734 OD	Nylon, Black	2
6	1/4" -20 Socket Head Screw, 1-1/2" length	Stainless Steel	2
7	Link & Lock Bracket -90 Center Sliding	6005A Aluminum	1

Dual Bracket for vertical substrate

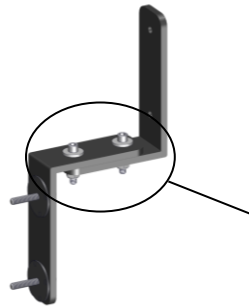
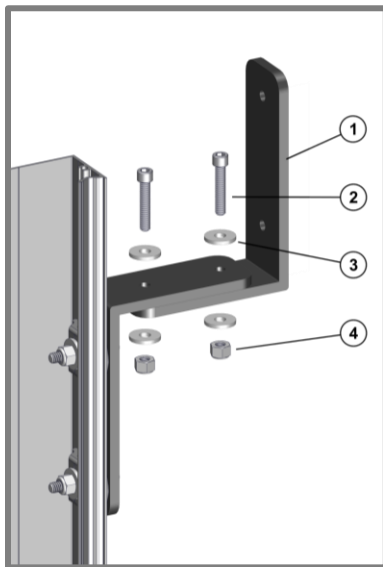

Dual Bracket components are pre-assembled by manufacturer. Do not adjust or remove unless authorized by the manufacturer.

No.	Description	Material	Qty
1	Link & Lock Dual Bracket -90 Center Fixed	6005A Aluminum	1
2	1/4" -20 Socket Head Screw, 1-1/4" length	Stainless Steel	2
3	Washer, 1/4" screw size, 0.75" OD	Stainless Steel	4
4	1/4" -20 Locknut	Stainless Steel Nylon-Insert	2

Install steps

Step 1

Layout & install Link & Lock Brackets. It is good practice to check for level/plumb and flat/straight, for best results.

⚠ TIP: Install one run of L&L Brackets with the L&L to confirm measurements.

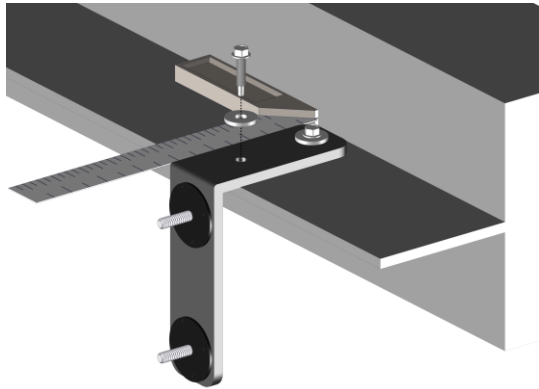

#12 Fasteners with washers by others (Min head diameter of 11mm)

X

X – see allowable span Table 9, Page 34

1 9/16" -for Sliding Bracket unloaded. For loaded condition check with your local engineer.

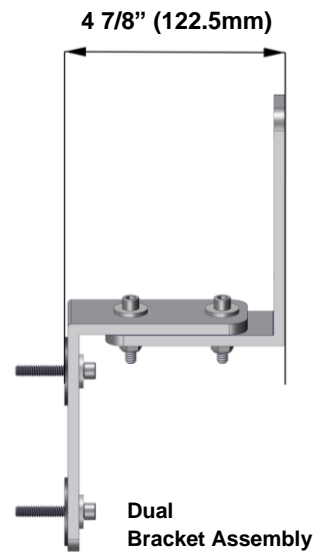
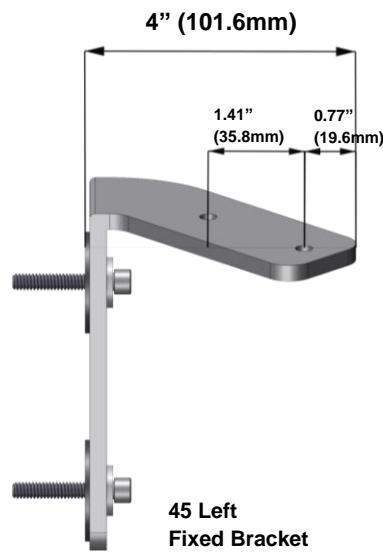
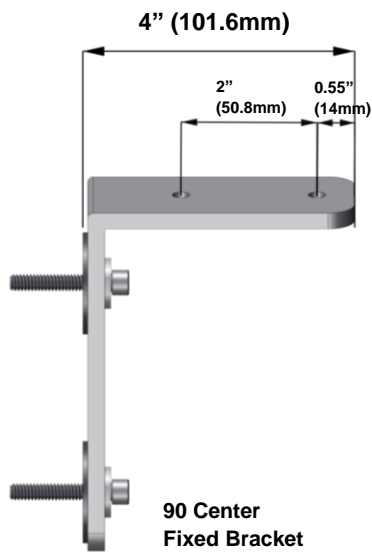

Step 2

Drill out back "L" of the Link & Lock.
For dimensions review drawing details provided by Longboard if required.

- **1/4" holes**
-for hard fastening one Bracket per run
-for Sliding Brackets if used
- **1/2" holes** for expansion & contraction on the rest of the Fixed Brackets

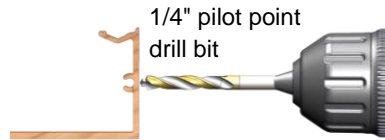

Step 3

Install back "L" onto brackets.

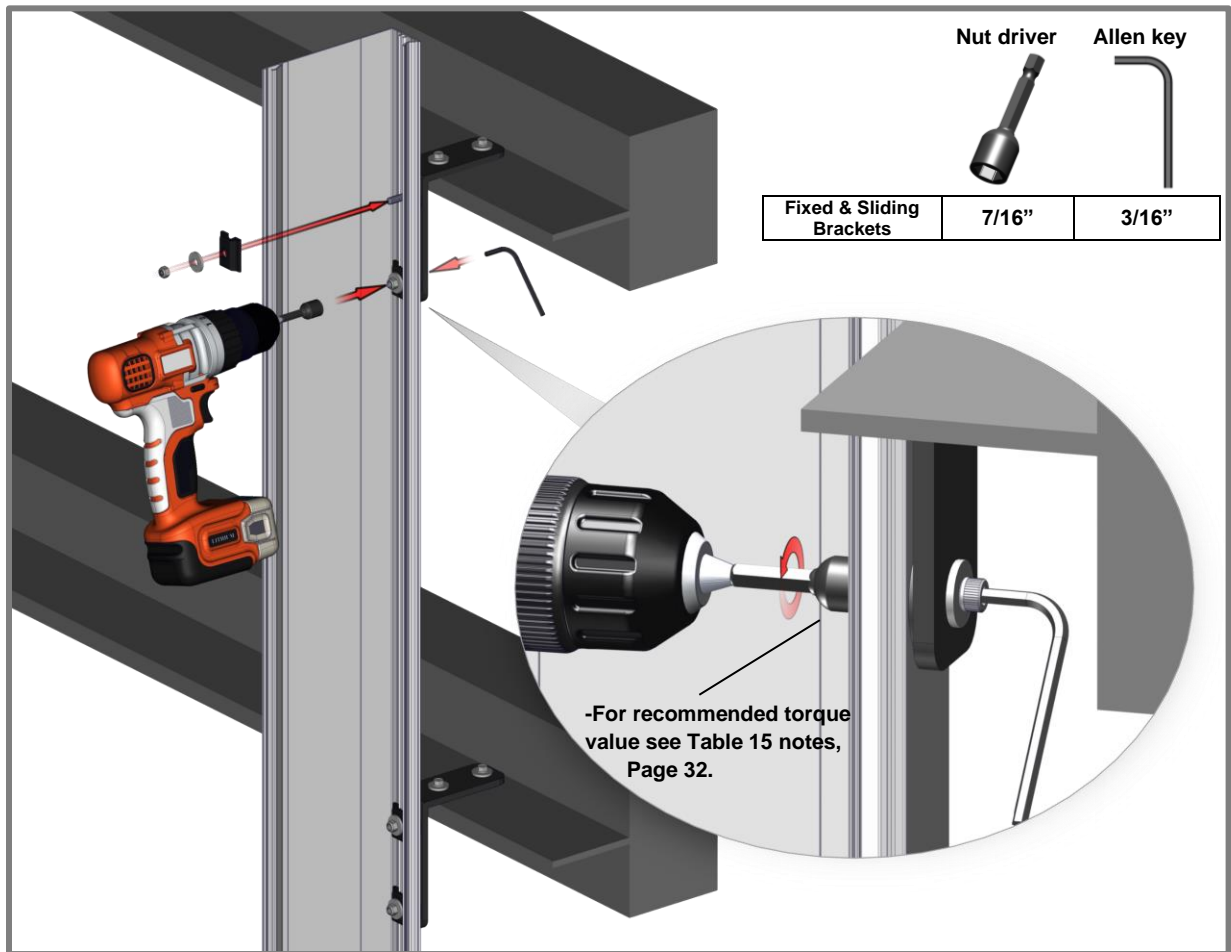

Step 3.1

Install Internal Stiffener if required. For install steps see Pages 19-20.

Step 4

Install front "L" onto back "L" and End Caps. For details See Pages 13-14, Steps 3 & 4.

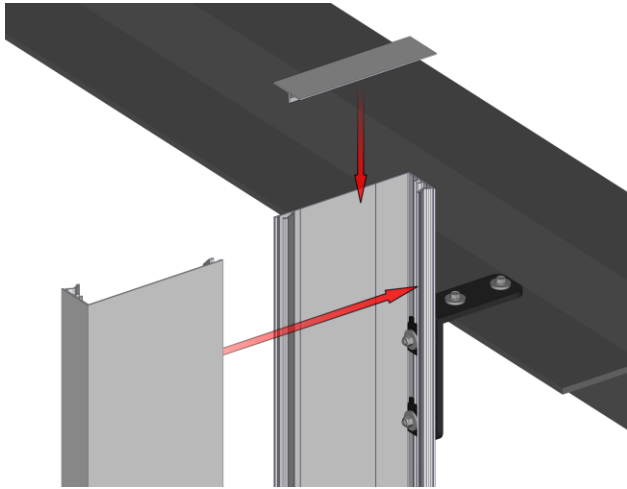

Appendix

Expansion and Contraction Tables

TABLE 1 - IMPERIAL

		AVERAGE TEMPERATURE AT TIME OF CUTTING & INSTALLATION											
°C		-50	-40	-30	-20	-10	0	10	20	30	40	50	
°F		-58	-40	-22	-4	14	32	50	68	86	104	122	
MIN/MAX POST CONSTRUCTION TEMP.	°C	°F	EXPANSION OR CONTRACTION (INCH/FOOT)										
	-50	-58	0.000	-0.003	-0.005	-0.008	-0.011	-0.014	-0.016	-0.019	-0.022	-0.024	-0.027
	-40	-40	0.003	0.000	-0.003	-0.005	-0.008	-0.011	-0.014	-0.016	-0.019	-0.022	-0.024
	-30	-22	0.005	0.003	0.000	-0.003	-0.005	-0.008	-0.011	-0.014	-0.016	-0.019	-0.022
	-20	-4	0.008	0.005	0.003	0.000	-0.003	-0.005	-0.008	-0.011	-0.014	-0.016	-0.019
	-10	14	0.011	0.008	0.005	0.003	0.000	-0.003	-0.005	-0.008	-0.011	-0.014	-0.016
	0	32	0.014	0.011	0.008	0.005	0.003	0.000	-0.003	-0.005	-0.008	-0.011	-0.014
	10	50	0.016	0.014	0.011	0.008	0.005	0.003	0.000	-0.003	-0.005	-0.008	-0.011
	20	68	0.019	0.016	0.014	0.011	0.008	0.005	0.003	0.000	-0.003	-0.005	-0.008
	30	86	0.022	0.019	0.016	0.014	0.011	0.008	0.005	0.003	0.000	-0.003	-0.005
	40	104	0.024	0.022	0.019	0.016	0.014	0.011	0.008	0.005	0.003	0.000	-0.003
	50	122	0.027	0.024	0.022	0.019	0.016	0.014	0.011	0.008	0.005	0.003	0.000

TABLE 2 - METRIC

		AVERAGE TEMPERATURE AT TIME OF CUTTING & INSTALLATION											
°C		-50	-40	-30	-20	-10	0	10	20	30	40	50	
°F		-58	-40	-22	-4	14	32	50	68	86	104	122	
MIN/MAX POST CONSTRUCTION TEMP.	°C	°F	EXPANSION OR CONTRACTION (MM/METER)										
	-50	-58	0.000	-0.230	-0.460	-0.690	-0.920	-1.150	-1.380	-1.610	-1.840	-2.070	-2.300
	-40	-40	0.230	0.000	-0.230	-0.460	-0.690	-0.920	-1.150	-1.380	-1.610	-1.840	-2.070
	-30	-22	0.460	0.230	0.000	-0.230	-0.460	-0.690	-0.920	-1.150	-1.380	-1.610	-1.840
	-20	-4	0.690	0.460	0.230	0.000	-0.230	-0.460	-0.690	-0.920	-1.150	-1.380	-1.610
	-10	14	0.920	0.690	0.460	0.230	0.000	-0.230	-0.460	-0.690	-0.920	-1.150	-1.380
	0	32	1.150	0.920	0.690	0.460	0.230	0.000	-0.230	-0.460	-0.690	-0.920	-1.150
	10	50	1.380	1.150	0.920	0.690	0.460	0.230	0.000	-0.230	-0.460	-0.690	-0.920
	20	68	1.610	1.380	1.150	0.920	0.690	0.460	0.230	0.000	-0.230	-0.460	-0.690
	30	86	1.840	1.610	1.380	1.150	0.920	0.690	0.460	0.230	0.000	-0.230	-0.460
	40	104	2.070	1.840	1.610	1.380	1.150	0.920	0.690	0.460	0.230	0.000	-0.230
	50	122	2.300	2.070	1.840	1.610	1.380	1.150	0.920	0.690	0.460	0.230	0.000

TABLE 3

LONGBOARD® <small>INSPIRING ARCHITECTURE</small>		FASTENER SPACING - LOAD TABLE										
		PSF (Factored / Ultimate)										
2" LINK & LOCK™		20	30	40	50	60	70	80	90	100	110	120
Standard												
ALLOWABLE SPAN (FT)*	4'											
	6'											
	8'											
	10'											
*CANTILEVERS are not to exceed half (1/2) the allowable span to a maximum of 3'												
<i>Calculations are using L/180 deflection limits</i>												
SUBSTRATE TYPE	SUBSTRATE REQUIREMENTS		ANCHOR DESCRIPTION		MIN. EMBEDMENT		MIN. EDGE DISTANCE					
WOOD	Min. specific gravity = 0.55 wood		#12 Pan Head Wood Screw		1-1/2"		1"					
STEEL	Min. 18 ga., Min. Fy=33 ksi.		#12 Self-Drilling or Self-Tapping Screw (Grade 5)		3 threads penetration past metal structure		1/2"					
ALUMINUM	Min. 1/8", Min. 8063-T5		3/16" ITW Tapcon		1-1/2"		1-3/4"					
CONCRETE	Min. 3000 psi				1"		2"					
HOLLOWGROUT-FILLED CMU	Conforms to ASTM C-90, with Min. compressive strength of 2000 psi											

GENERAL NOTES:

- This product has been designed and manufactured to comply with the current Florida Building Code (FBC), **INCLUDING** HVHZ and has been evaluated according to the following:
 - Section 1709.8
 - ASTM E8-16
- Adequacy of the structural concrete/masonry and 2X framing as a main wind force resisting system capable of withstanding and transferring applied product loads to the foundation is the responsibility of the engineer or architect of record for the project of installation.
- Substrate shall be designed and anchored to properly transfer all loads to the structure. Buck design and installation is the responsibility of the engineer or architect of record for the project of installation.
- The installation details described herein are generic and may not reflect actual conditions for a specific site. If site conditions cause installation to deviate from the requirements detailed herein, a licensed engineer or architect shall prepare site specific documents for use with this document.
- Link & Lock is not designed to be a life-safety item. Designs of this nature are the responsibility of the engineer or architect of record.

INSTALLATION NOTES:

- One (1) installation anchor is required at each location. Minimum of two (2) anchors per batten.
- Spacing is from fastener center to center.
- The number of installation anchors per the table is the minimum number of anchors to be used for product installation.
- Install individual installation anchors within a tolerance of +/- 1/2" of the specified spacings. Tolerances are not cumulative from one installation anchor to the next.
- Minimum embedment and edge distance exclude wall finishes, including but not limited to stucco, foam, brick veneer, sheathing and siding.
- Installation anchors and associated hardware must be made of corrosion resistant material or have a corrosion resistant coating. Common fastener types can be equal or better to a & b listed below.
 - Zinc plated fasteners for moderate climate zones
 - 316 Stainless Steel fasteners for coastal climate zones
- For hollow block and grout filled CMU block, do not install installation anchors into mortar joints. Edge distance is measured from free edge of block or edge of mortar joint into face shell of block.
- Installation anchors shall be installed in accordance with anchor manufacturer's installation instructions, and anchors shall not be used in substrates with strengths less than the minimum strength specified by the anchor manufacturer.
- When using end mounts, span distance is measured center to center of each end mount.

TABLE 4

4" LINK & LOCK™			FASTENER SPACING - LOAD TABLE												
			PSF (Factored / Ultimate)												
Standard	Standard w. Stiffener	HD	20	30	40	50	60	70	80	90	100	110	120		
ALLOWABLE SPAN (FT)*			2'												
			4'							Standard w. Stiffener					
			6'						Standard w. Stiffener		HD				
			8'			Standard w. Stiffener		HD							
			10'		Standard w. Stiffener		HD								
			12'		Standard w. Stiffener		HD								

*CANTILEVERS are not to exceed half (1/2) the allowable span to a maximum of 3'

Calculations are using L/180 deflection limits

SUBSTRATE TYPE	SUBSTRATE REQUIREMENTS	ANCHOR DESCRIPTION	MIN. EMBEDMENT	MIN. EDGE DISTANCE
WOOD	Min. specific gravity = 0.55 wood	#12 Pan Head Wood Screw	1-1/2"	1"
STEEL	Min. 18 ga., Min. Fy=33 ksi.	#12 Self-Drilling or Self-Tapping Screw (Grade 5)	3 threads penetration past metal structure	1/2"
ALUMINUM	Min. 1/8", Min. 6063-T5			
CONCRETE	Min. 3000 psi	3/16" ITW Tapcon	1-1/2"	1-3/4"
HOLLOW/GROUT-FILLED CMU	Conforms to ASTM C-90, with Min. compressive strength of 2000 psi		1"	2"

GENERAL NOTES:

- This product has been designed and manufactured to comply with the current Florida Building Code (FBC), **INCLUDING** HVHZ and has been evaluated according to the following:
 - Section 1709.8
 - ASTM E8-16
- Adequacy of the structural concrete/masonry and 2X framing as a main wind force resisting system capable of withstanding and transferring applied product loads to the foundation is the responsibility of the engineer or architect of record for the project of installation.
- Substrate shall be designed and anchored to properly transfer all loads to the structure. Buck design and installation is the responsibility of the engineer or architect of record for the project of installation.
- The installation details described herein are generic and may not reflect actual conditions for a specific site. If site conditions cause installation to deviate from the requirements detailed herein, a licensed engineer or architect shall prepare site specific documents for use with this document.
- Link & Lock is not designed to be a life-safety item. Designs of this nature are the responsibility of the engineer or architect of record.

INSTALLATION NOTES:

- One (1) installation anchor is required at each location. Minimum of two (2) anchors per batten.
- Spacing is from fastener center to center.
- The number of installation anchors per the table is the minimum number of anchors to be used for product installation.
- Install individual installation anchors within a tolerance of +/- 1/2" of the specified spacings. Tolerances are not cumulative from one installation anchor to the next.
- Minimum embedment and edge distance exclude wall finishes, including but not limited to stucco, foam, brick veneer, sheathing and siding.
- Installation anchors and associated hardware must be made of corrosion resistant material or have a corrosion resistant coating. Common fastener types can be equal or better to a & b listed below:
 - Zinc plated fasteners for moderate climate zones
 - 316 Stainless Steel fasteners for coastal climate zones
- For hollow block and grout filled CMU block, do not install installation anchors into mortar joints. Edge distance is measured from free edge of block or edge of mortar joint into face shell of block.
- Installation anchors shall be installed in accordance with anchor manufacturer's installation instructions, and anchors shall not be used in substrates with strengths less than the minimum strength specified by the anchor manufacturer.
- When using end mounts, span distance is measured center to center of each end mount.

TABLE 5

6" LINK & LOCK™			FASTENER SPACING - LOAD TABLE												
			PSF (Factored / Ultimate)												
Standard	Standard w. Stiffener	HD	20	30	40	50	60	70	80	90	100	110	120		
ALLOWABLE SPAN (FT)*			2'												
			4'											Standard w. Stiffener	
			6'				Standard w. Stiffener	HD							
			8'	Standard w. Stiffener			HD								
			10'	Standard w. Stiffener			HD								
			12'	HD											
*CANTILEVERS are not to exceed half (1/2) the allowable span to a maximum of 3'															
<i>Calculations are using L/180 deflection limits</i>															
SUBSTRATE TYPE	SUBSTRATE REQUIREMENTS		ANCHOR DESCRIPTION		MIN. EMBEDMENT		MIN. EDGE DISTANCE								
WOOD	Min. specific gravity = 0.55 wood		#12 Pan Head Wood Screw		1-1/2"		1"								
STEEL	Min. 18 ga., Min. Fy=33 ksi.		#12 Self-Drilling or Self-Tapping Screw (Grade 5)		3 threads penetration past metal structure		1/2"								
ALUMINUM	Min. 1/8", Min. 6063-T5														
CONCRETE	Min. 3000 psi		3/16" ITW Tapcon		1-1/2"		1-3/4"								
HOLLOW/GROUT-FILLED CMU	Conforms to ASTM C-90, with Min. compressive strength of 2000 psi				1"		2"								
GENERAL NOTES:															
1. This product has been designed and manufactured to comply with the current Florida Building Code (FBC), INCLUDING HVHZ and has been evaluated according to the following: - Section 1709.8 - ASTM E8-16															
2. Adequacy of the structural concrete/masonry and 2X framing as a main wind force resisting system, capable of withstanding and transferring applied product loads to the foundation is the responsibility of the engineer or architect of record for the project of installation.															
3. Substrate shall be designed and anchored to properly transfer all loads to the structure. Buck design and installation is the responsibility of the engineer or architect of record for the project of installation.															
4. The installation details described herein are generic and may not reflect actual conditions for a specific site. If site conditions cause installation to deviate from the requirements detailed herein, a licensed engineer or architect shall prepare site specific documents for use with this document.															
5. Link & Lock is not designed to be a life-safety item. Designs of this nature are the responsibility of the engineer or architect of record.															
INSTALLATION NOTES:															
1. One (1) installation anchor is required at each location. Minimum of two (2) anchors per batten.															
2. Spacing is from fastener center to center.															
3. The number of installation anchors per the table is the minimum number of anchors to be used for product installation.															
4. Install individual installation anchors within a tolerance of +/- 1/2" of the specified spacings. Tolerances are not cumulative from one installation anchor to the next.															
5. Minimum embedment and edge distance exclude wall finishes, including but not limited to stucco, foam, brick veneer, sheathing and siding.															
6. Installation anchors and associated hardware must be made of corrosion resistant material or have a corrosion resistant coating. Common fastener types can be equal or better to a & b listed below: a. Zinc plated fasteners for moderate climate zones b. 316 Stainless Steel fasteners for coastal climate zones															
7. For hollow block and grout filled CMU block, do not install installation anchors into mortar joints. Edge distance is measured from free edge of block or edge of mortar joint into face shell of block.															
8. Installation anchors shall be installed in accordance with anchor manufacturer's installation instructions, and anchors shall not be used in substrates with strengths less than the minimum strength specified by the anchor manufacturer.															
9. When using end mounts, span distance is measured center to center of each end mount.															

TABLE 6

8" LINK & LOCK™			PSF (Factored / Ultimate)											
Standard	Standard w. Stiffener	HD	20	30	40	50	60	70	80	90	100	110	120	
ALLOWABLE SPAN (FT)*			2'											
			4'					Standard w. Stiffener						HD
			6'			Standard w. Stiffener	HD							
			8'	Standard w. Stiffener	HD									
			10'	HD										

*CANTILEVERS are not to exceed half (1/2) the allowable span to a maximum of 3'

Calculations are using L/180 deflection limits

SUBSTRATE TYPE	SUBSTRATE REQUIREMENTS	ANCHOR DESCRIPTION	MIN. EMBEDMENT	MIN. EDGE DISTANCE
WOOD	Min. specific gravity = 0.55 wood	#12 Pan Head Wood Screw	1-1/2"	1"
STEEL	Min. 18 ga., Min. Fy=33 ksi.	#12 Self-Drilling or Self-Tapping Screw (Grade 5)	3 threads penetration past metal structure	1/2"
ALUMINUM	Min. 1/8", Min. 6063-T5			
CONCRETE	Min. 3000 psi	3/16" ITW Tapcon	1-1/2"	1-3/4"
HOLLOW/GROUT-FILLED CMU	Conforms to ASTM C-90, with Min. compressive strength of 2000 psi		1"	2"

GENERAL NOTES:

- This product has been designed and manufactured to comply with the current Florida Building Code (FBC), **INCLUDING** HVHZ and has been evaluated according to the following:
 - Section 1709.8
 - ASTM E8-16
- Adequacy of the structural concrete/masonry and 2X framing as a main wind force resisting system capable of withstanding and transferring applied product loads to the foundation is the responsibility of the engineer or architect of record for the project of installation.
- Substrate shall be designed and anchored to properly transfer all loads to the structure. Buck design and installation is the responsibility of the engineer or architect of record for the project of installation.
- The installation details described herein are generic and may not reflect actual conditions for a specific site. If site conditions cause installation to deviate from the requirements detailed herein, a licensed engineer or architect shall prepare site specific documents for use with this document.
- Link & Lock is not designed to be a life-safety item. Designs of this nature are the responsibility of the engineer or architect of record.

INSTALLATION NOTES:

- One (1) installation anchor is required at each location. Minimum of two (2) anchors per batten.
- Spacing is from fastener center to center.
- The number of installation anchors per the table is the minimum number of anchors to be used for product installation.
- Install individual installation anchors within a tolerance of +/- 1/2" of the specified spacings. Tolerances are not cumulative from one installation anchor to the next.
- Minimum embedment and edge distance exclude wall finishes, including but not limited to stucco, foam, brick veneer, sheathing and siding.
- Installation anchors and associated hardware must be made of corrosion resistant material or have a corrosion resistant coating. Common fastener types can be equal or better to a & b listed below:
 - Zinc plated fasteners for moderate climate zones
 - 316 Stainless Steel fasteners for coastal climate zones
- For hollow block and grout filled CMU block, do not install installation anchors into mortar joints. Edge distance is measured from free edge of block or edge of mortar joint into face shell of block.
- Installation anchors shall be installed in accordance with anchor manufacturer's installation instructions, and anchors shall not be used in substrates with strengths less than the minimum strength specified by the anchor manufacturer.
- When using end mounts, span distance is measured center to center of each end mount.

TABLE 7



FASTENER SPACING - LOAD TABLE

v.1.2

4X4 LINK & LOCK™		PSF (Factored / Ultimate)										
		20	30	40	50	60	70	80	90	100	110	120
Standard												
ALLOWABLE SPAN (FT)*	8'											
	10'											
	12'											

*CANTILEVERS are not to exceed 3'

Calculations are using L/180 deflection limits

SUBSTRATE TYPE	SUBSTRATE REQUIREMENTS	ANCHOR DESCRIPTION	MIN. EMBEDMENT	MIN. EDGE DISTANCE
WOOD	Min. specific gravity = 0.55 wood	#12 Pan Head or Flanged Hex Head Wood Screw	1-1/2"	1"
STEEL	Min. 18 ga., Min. Fy=36 ksi.	#12 Self-Drilling or Self-Tapping Screw Pan Head or Flanged Hex Head Wood Screw (Grade 5)	3 threads penetration past metal structure	1/2"
ALUMINUM	Min. 1/8", Min. 6063-T5			
CONCRETE	Min. 3000 psi	3/16" ITW Tapcon	1-1/2"	1-3/4"
HOLLOW/GROUT-FILLED CMU	Conforms to ASTM C-90, with Min. compressive strength of 2000 psi		1"	2"

GENERAL NOTES:

- Adequacy of the structural concrete/masonry and 2X framing as a main wind force resisting system capable of withstanding and transferring applied product loads to the foundation is the responsibility of the engineer or architect of record for the project of installation.
- Substrate shall be designed and anchored to properly transfer all loads to the structure. Buck design and installation is the responsibility of the engineer or architect of record for the project of installation.
- The installation details described herein are generic and may not reflect actual conditions for a specific site. If site conditions cause installation to deviate from the requirements detailed herein, a licensed engineer or architect shall prepare site specific documents for use with this document.
- Link & Lock is not designed to be a life-safety item. Designs of this nature are the responsibility of the engineer or architect of record.

INSTALLATION NOTES:

- One (1) installation anchor is required at each location. Minimum of two (2) anchors per batten.
- Spacing is from fastener center to center.
- The number of installation anchors per the table is the minimum number of anchors to be used for product installation.
- Install individual installation anchors within a tolerance of +/- 1/2" of the specified spacings. Tolerances are not cumulative from one installation anchor to the next.
- Minimum embedment and edge distance exclude wall finishes, including but not limited to stucco, foam, brick veneer, sheathing and siding.
- Installation anchors and associated hardware must be made of corrosion resistant material or have a corrosion resistant coating. Common fastener types can be equal or better to a & b listed below:
 - Zinc plated fasteners for moderate climate zones
 - 316 Stainless Steel fasteners for coastal climate zones
- For hollow block and grout filled CMU block, do not install installation anchors into mortar joints. Edge distance is measured from free edge of block or edge of mortar joint into face shell of block.
- Installation anchors shall be installed in accordance with anchor manufacturer's installation instructions, and anchors shall not be used in substrates with strengths less than the minimum strength specified by the anchor manufacturer.

TABLE 8

LONGBOARD[®] INSPIRING ARCHITECTURE		FASTENER SPACING - LOAD TABLE										
		PSF (Factored / Ultimate)										
4X6 LINK & LOCK™		20	30	40	50	60	70	80	90	100	110	120
Standard												
ALLOWABLE SPAN (FT)*	8'											
	10'											
	12'											
*CANTILEVERS are not to exceed 3'												
<i>Calculations are using L/180 deflection limits</i>												
SUBSTRATE TYPE	SUBSTRATE REQUIREMENTS		ANCHOR DESCRIPTION				MIN. EMBEDMENT		MIN. EDGE DISTANCE			
WOOD	Min. specific gravity = 0.55 wood		#12 Pan Head or Flanged Hex Head Wood Screw				1-1/2"		1"			
STEEL	Min. 18 ga., Min. Fy=36 ksi.		#12 Self-Drilling or Self-Tapping Screw Pan Head or Flanged Hex Head Wood Screw (Grade 5)				3 threads penetration past metal structure		1/2"			
ALUMINUM	Min. 1/8", Min. 6063-T5											
CONCRETE	Min. 3000 psi		3/16" ITW Tapcon				1-1/2"		1-3/4"			
HOLLOW/GROUT-FILLED CMU	Conforms to ASTM C-90, with Min. compressive strength of 2000 psi						1"		2"			

GENERAL NOTES:

- Adequacy of the structural concrete/masonry and 2X framing as a main wind force resisting system capable of withstanding and transferring applied product loads to the foundation is the responsibility of the engineer or architect of record for the project of installation.
- Substrate shall be designed and anchored to properly transfer all loads to the structure. Buck design and installation is the responsibility of the engineer or architect of record for the project of installation.
- The installation details described herein are generic and may not reflect actual conditions for a specific site. If site conditions cause installation to deviate from the requirements detailed herein, a licensed engineer or architect shall prepare site specific documents for use with this document.
- Link & Lock is not designed to be a life-safety item. Designs of this nature are the responsibility of the engineer or architect of record.

INSTALLATION NOTES:

- One (1) installation anchor is required at each location. Minimum of two (2) anchors per batten.
- Spacing is from fastener center to center.
- The number of installation anchors per the table is the minimum number of anchors to be used for product installation.
- Install individual installation anchors within a tolerance of +/- 1/2" of the specified spacings. Tolerances are not cumulative from one installation anchor to the next.
- Minimum embedment and edge distance exclude wall finishes, including but not limited to stucco, foam, brick veneer, sheathing and siding.
- Installation anchors and associated hardware must be made of corrosion resistant material or have a corrosion resistant coating. Common fastener types can be equal or better to a & b listed below:
 - Zinc plated fasteners for moderate climate zones
 - 316 Stainless Steel fasteners for coastal climate zones
- For hollow block and grout filled CMU block, do not install installation anchors into mortar joints. Edge distance is measured from free edge of block or edge of mortar joint into face shell of block.
- Installation anchors shall be installed in accordance with anchor manufacturer's installation instructions, and anchors shall not be used in substrates with strengths less than the minimum strength specified by the anchor manufacturer.

TABLE 9

LONGBOARD[®] INSPIRING ARCHITECTURE	LINK & LOCK™ BRACKET MAX. SPACING (FT)										
	WIND LOAD PSF (FACTORED/ULTIMATE)										
LINK & LOCK™ BATTEN	30	40	50	60	70	80	90	100	110	120	
1-5/8" x 2"	10'	8'			6'		4'			2'	
1-5/8" x 4"	8'	6'			4'					2'	
1-5/8" x 4" w. Internal Stiffener	12'	10'	8'		6'					4'	
1-5/8" x 6"	6'		4'				3'			2'	
1-5/8" x 6" w. Internal Stiffener	10'	8'	6'		4'				3'	2'	
1-5/8" x 8"	6'	4'					2'				
1-5/8" x 8" w. Internal Stiffener	8'	6'		4'			3'			2'	
2" x 4" HD	12'	10'	8'		6'					4'	
2" x 6" HD	10'	8'	6'		4'					3'	
2" x 8" HD	8'	6'	4'				3'			2'	

Recommended torque value for Link & Lock™ to Bracket attachment:

note 1 Factored Wind Load: max. 168 LBS/EA Bracket

note 2 Factored Dead Load: max. 29 LBS/EA Fixed Bracket

note 3 Fixed Bracket 1/4" -20 Socket Head Screw, 60-72 in/lbs + prevailing torque of self-locking nut

note 4 Sliding Bracket 1/4" -20 Socket Head Screw, 48-60 in/lbs + prevailing torque of self-locking nut

April 25, 2024

Proper Handling of Longboard Products



To help avoid injury and product damage, Longboard products require proper handling to and from storage areas during installation. When carrying or installing any products it is recommended that they be moved or carried by at least two people with each support point approximately 4ft from the ends. **Carrying products without proper support can cause excessive bending which may damage the appearance or finish of the product.** Any short cut lengths should also be carried on edge while supporting the material. See below for details.

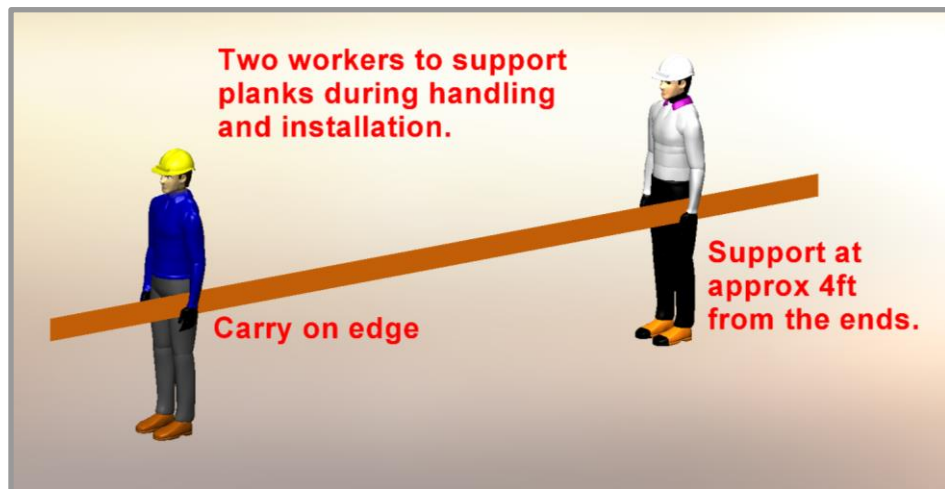
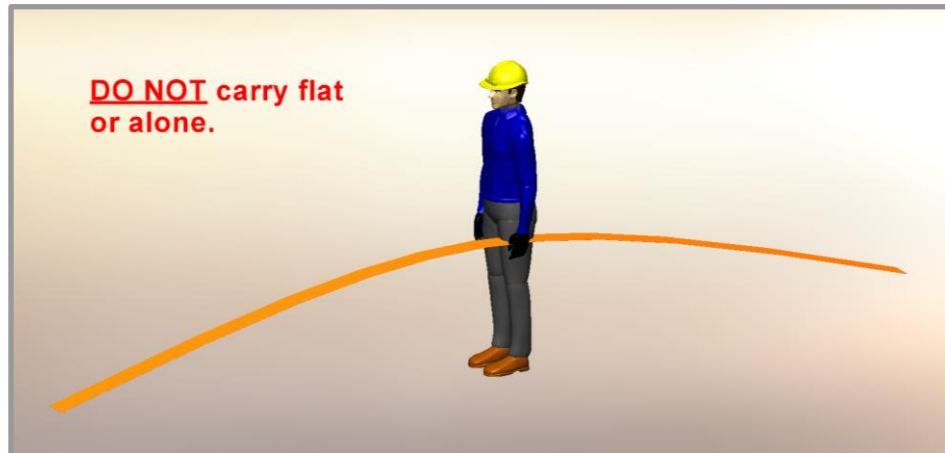

⚠️ Delivery, Storage & Handling ⚠️

- Always inspect the delivery for damage and contact LB ASAP if there are any issues: info@longboardproducts.com or 1-800-604-0343 and include your PO# and any pictures if possible. Longboard is not responsible for the installation of blemished or damaged material.
- Be sure to store the material flat, keep it dry, safe & secure and remain in unopened cartons until ready to be installed.
- Always wear appropriate PPE when handling products.



Longboard Architectural Products Inc.
© Longboard Architectural Products Inc. All rights reserved.

Longboard® is a registered trademark of Longboard Architectural Products Inc.

Longboard
1777 Clearbrook Road
Abbotsford, BC V2T 8X8
Canada
longboardproducts.com

Every effort has been made to ensure that the information in these installation guidelines is accurate. Longboard is not responsible for printing or clerical errors.

For more information, contact client care at info@longboardproducts.com or call toll free 1-800-604-0343.



Tongue & Groove Systems

V-Groove Planks

Size	* 48 sq. ft. box quantities		* 96 sq. ft. box quantities	
	12' *	24' *	12' Perf *	24' Perf *
2½"	3V.145	-	3VP.145	-
4"	4V.145	4V.289	-	-
6"	6V.145	6V.289	6VP.145	6VP.289

Smooth Planks

Size	12' *	24' *	12' Perf *	24' Perf *
6"	6PSP.145	6PSP.289	6PSPP.145	6PSPP.289

Channel Planks

Size	12' *	24' *	12' Perf *	24' Perf *
6"	6CH.145	6CH.289	-	-

Bevel Planks

Size	12' *	24' *	12' Perf *	24' Perf *
6" Single	6SB.145	6SB.289	-	-
6" Triple	6TB.145	6TB.289	-	-

Castellation Planks

Size	12' *	24' *	12' Perf *	24' Perf *
4"	4CA.145	4CA.289	-	-
8"	8CA.145	8CA.289	-	-



V-Groove Planks



Smooth Planks



Channel Planks



Perforated Planks



Bevel Planks



Castellation Planks



Butt Joint Fastening Kit



Quick Screen Clips



U-Shim



Touch-up Pens

Accessories

Product	Qty	SKU
Quick Screen Clips	1750, box	CLIP.N1750
Quick Screen Clips	100, bag	CLIP.N100
1/16" U-SHIM	250, bag	SHIM.1001
Butt-Joint Fastening Kit (6")	20 kits, bag	TGBJKIT
Touch Up Pens <i>Reach out to confirm color with account manager.</i>	N/A	TUP

Trim Components

Type	Style	Product	Dimensions	SKU
Starter	Precision	Starter J-Track	(5/8") - 12'	1SJT.145
Starter	Traditional	Starter Strip	(1-7/8") - 12'	2SS.145
Starter	Traditional	Back-to-Back Starter Strip	(1-1/4")	2BTBSS.145
J-Track	Precision	Two Piece J-Track	(5/8") - 12'	1X1JT.145
J-Track	Precision	J-Track	(5/8") - 12'	1JT.145
J-Track	Craftsman	J-Track	(7/8") - 12'	JT23.145
J-Track	Craftsman	Two Piece J-Track	(7/8") - 12'	JT23S.145
J-Track	Traditional	Two Piece J-Track	(1-3/8") - 12'	1X2JT.145
Corner	Precision	Outside Corner	(3/16") - 12'	05OC.145
Corner	Craftsman	Inside Corner	(3/4") - 12'	1IC.145
Corner	Craftsman	Outside Corner	(1") - 12'	1OC.145
Corner	Traditional	Corner Set	(2") - 12'	2CORS.145
Corner	Traditional	3" Smooth	(3") - 24'	3SCP.289
Corner	Traditional	3" V-Groove	(3") - 24'	3SVP.289
Reveal	Precision	Flat Reveal	(1/2") - 12'	1FR.145
Reveal	Precision	T&G Flat Reveal	(1/2") - 24'	1TGFR.289
Reveal	Craftsman	U-Reveal Set	(3/4") - 12'	1URS.145
Reveal	Craftsman	T&G U-Reveal	(3/4) - 24'	1TGURK.289
Reveal	Traditional	U-Reveal Set	(1-1/2") - 12'	2URS.145
Reveal	Traditional	Flat Reveal Set	(1-1/2") - 12'	2FRS.145
Reveal	Traditional	T&G U-Reveal	(1 1/2") - 24'	2TGURK.289
Reveal	Traditional	Offset Flat Reveal Set, J-Track Base	(2") - 12'	2OFFJ.145
Reveal	Traditional	Offset Flat Reveal Set, Termination Base	(2") - 12'	2OFFT.145
Termination	Precision	Termination Set	(5/8") - 12'	1TS.145
Termination	Craftsman	Termination Set	(7/8") - 12'	TS23S.145
Termination	Traditional	Termination Set	(1-3/8") - 12'	2TS.145
Compression Joints	Traditional	Compression Joint	(1-3/8") - 24'	2CJ.289

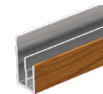

Precision Starter J-Track



Traditional Starter Strip



Traditional Back-to-Back Starter Strip



Precision Two-Piece J-Track



Precision J-Track



Craftsman J-Track



Craftsman Two Piece J-Track



Traditional Two Piece J-Track



Precision Outside Corner



Craftsman Inside Corner



Craftsman Outside Corner



Traditional Corner Set



Traditional 3" Smooth Corner



Traditional 3" V Groove Corner



Precision Flat Reveal



Precision T&G Flat Reveal



Craftsman U-Reveal Set

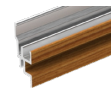

Craftsman T&G U-Reveal



Traditional U-Reveal Set



Traditional Flat Reveal Set



Traditional T&G U-Reveal



Traditional Offset Flat Reveal Set, J-Track Base



Traditional Offset Flat Reveal Set, Termination Base



Precision Termination Set



Craftsman Termination Set



Traditional Termination Set



Traditional Compression Joint

Residential Systems

Lap Siding 48 sq. ft. box quantities

Size	12'
6"	6L.145

Board & Batten 56 sq.ft. box quantities

Size	12'
7"	7BB.145

Accessories

Product	Qty	SKU
Quick Screen Clips	1750, box	CLIP.N1750
Quick Screen Clips	100, bag	CLIP.N100
1/16" U-SHIM	250, bag	SHIM.1001
Butt- Joint Fastening Kit (6")	20 kits, bag	TGBJKIT
Touch Up Pens <i>Reach out to confirm color with account manager.</i>	N/A	TUP

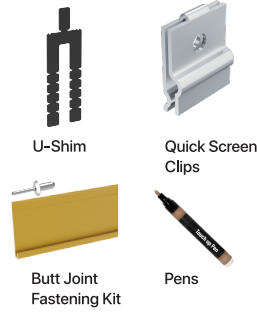

Trim Components

Type	Style	Product	Dimensions	SKU
J Track	Traditional	J Track	(1-3/8")-12'	JT35.145
J Track	Traditional	Two Piece J Track	(1-3/8")-12'	JT23S.145
Compression	Traditional	Compression Joint	(1-3/8")-12'	2CJ.289
Corner	Traditional	Corner Set	(1"-2") - 12'	2CORS.145
Reveal	Traditional	Flat Reveal Set	(1-1/2") - 12'	2FRS.145
Reveal	Traditional	Offset Flat Reveal Set	(2") - 12'	2OFFJ.145
Reveal	Traditional	U-Reveal Set	(1-1/2") - 12'	2URS.145
Starter	Traditional	Back to Back Starter	(5.5")-12'	6BTBS.145
Starter	Traditional	Starter Strip	(1-7/8")-12'	2SS.145
Drip Edge	Traditional	Drip Edge	(1-3/8")-12'	2DE.145

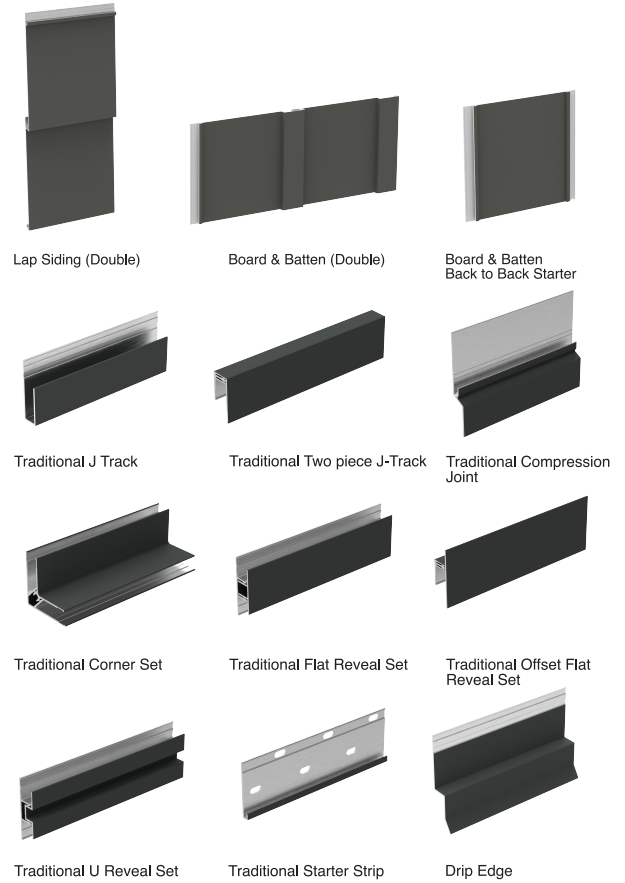

Link & Lock™ Battens

Size	12'	24'	End Caps (20/box)	End Mounts (20/box)
2"	2X2LL.145	2X2LL.289	2LLEC.2	2LLEM.2
4"	2X4LL.145	2X4LL.289	2LLEC.4	2LLEM.4
6"	2X6LL.145	2X6LL.289	2LLEC.6	2LLEM.6
8"	2X8LL.145	2X8LL.289	2LLEC.8	2LLEM.8

Link & Lock™ HD Battens

4"	2X4LLHD.145	2X4LLHD.289	2LLHDEC.4	2LLHDEM.4
6"	2X6LLHD.145	2X6LLHD.289	2LLHDEC.6	2LLHDEM.6
8"	2X8LLHD.145	2X8LLHD.289	2LLHDEC.8	2LLHDEM.8

Link & Lock™ Box Battens

4 x 4"	4X4LL.145	4X4LL.289	4LLEC.4	-
4 x 6"	4X6LL.145	4X6LL.289	4LLEC.6	-

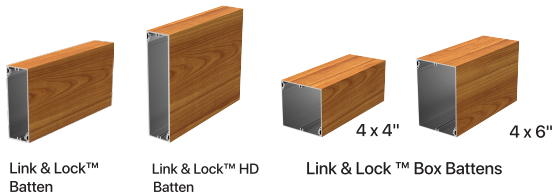

Mounting Accessories

Product	Qty	SKU
Link & Lock Mounting Clip	48, bag	LLMC.N48
Link & Lock™ Isolation Washer	48, bag	FAST.5003.BOX48
Dewalt® 1/2" Pilot Point Drill Bit	1	DRILLBT.05
24' Link & Lock Internal Stiffener	1	LLSTIFF.289
3M® Double Sided Adhesive Tape - 108'	1, roll	LLTAPE.1296



Link & Lock™ Mounting Brackets

Product	Single	Dual
45° LEFT FIXED	LLMBK.45LF	LLMDK.45LF
45° RIGHT FIXED	LLMBK.45RF	LLMDK.45RF
90° CENTER FIXED	LLMBK.90F	LLMDK.90F
45° LEFT SLIDING	LLMBK.45LS	LLMDK.45LS
45° RIGHT SLIDING	LLMBK.45RS	LLMDK.45RS
90° CENTER SLIDING	LLMBK.90S	LLMDK.90S

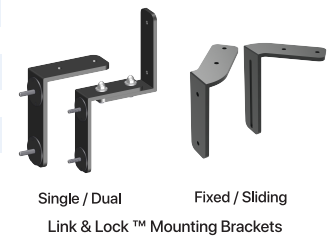

Privacy Beam System

Size	Product	24'	End Caps (20/box)
1x3"	Privacy Beam	1X3B.289	1BEC.3
1x5"	Privacy Beam	1X5B.289	1BEC.5
2x2"	Single Post	2X2SP.289	2X2PC.2
2x3"	Double Post	2X3DP.289	2X3PC.3

Mounting Accessories

Product	Qty	SKU
Spacer Block	100, box	2X2SB.N100
1" Spacer Bar Stock Length	1	1X2FB.145
1x3" Spacer Bar	100, box	1X2FB.1
1x5" Spacer Bar	100, box	1X2FB.3
3" Mounting Bracket	100, box	3PSMB.1
#10 Black Screws	100, box	PECS.N100

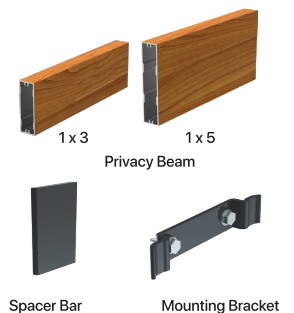

Scan the QR code to explore our Finishes on our Website

Achieve your Vision.

+1 800 604 0343

longboardproducts.com • info@longboardproducts.com



Finish Options

Achieve your vision.

Whether creating a space that offers the warmth and appearance of Woodgrains, or the modern industrialized look of Naturally Aged Metals, we have a finish option for you.

Require a custom finish or color? Our experienced color-matching team can make it a reality!

Contact us to confirm lead times for orders greater than 15k sq.ft in the Most Popular Finishes category.

Longboard Finish Classification

Type: Woodgrain / Solid / Metallic / Speckle / Naturally Aged Metal
Surface: Smooth / Textured
Sheen: Matte / Satin / Glossy
Performance: AAMA 2604 / AAMA 2605
Finish Warranty: 15 Year / 20 Year



Click / Scan the QR code to check our latest lead times and explore available options!

Woodgrains

Longboard's woodgrain finishes have a slight texture with matte sheen.



Solid & Specialty

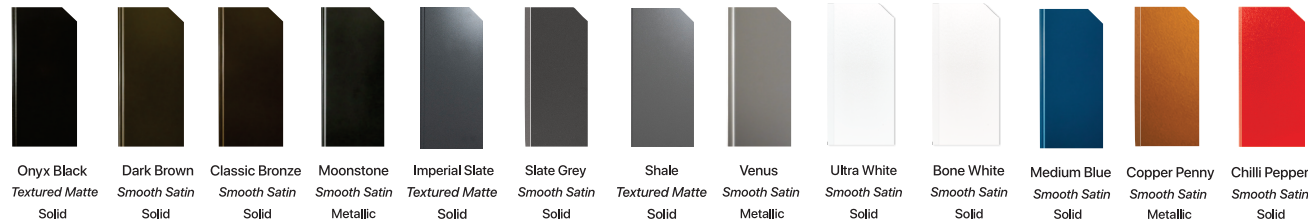

Speckle



Naturally Aged Metals



Print, Screens, and our pictures do not accurately reflect aspects of our finishes – textures, sheen, woodgrain hues, etc. Always order a physical sample before purchase! Our Color Bars swatches and samples will provide an accurate representation.

If a custom finish is required, we will work with our industry leading coating suppliers to develop a custom finish solution. All finishes are rigorously tested for corrosion and weathering resistance to ensure that it will stand up and deliver superior performance in the built environment.

We perform accelerated weathering testing in our onsite laboratory and work closely with coating suppliers to review weathering results of finishes undergoing natural Florida exposure testing. Our disciplined approach to powder coating, quality and process control distinguishes it as industry leading product manufacturer and ensures that its premium products stay looking beautiful for many, many years.

15 Year Non-Prorated Powder Coating Finish - 50 Year Non-Prorated Extruded Aluminum Profiles [Limited Warranty]

Warranty granted to (building owner):

--

Longboard Architectural Products Inc. ("Longboard," "The Company") products as identified by the Product Codes listed will conform to the standards set out in Clause 1 and Clause 2 of this Warranty, subject to the terms and conditions set out in Clause 3 and 4 of this Warranty.

Product codes: Product description:

Finish:	

Install contractor	
Project name	
Project address	
Address 2	Install start date
Date of substantial completion	

This Pinnacle Warranty is only valid for applications within Canada and USA. All applications outside of Canada and USA are required to contact Longboard for assistance.

- Clause 1**
 Extruded Aluminum Profile(s) with Powder Coat Finish Longboard expressly warrants that its product line is free from manufacturing defects in material or workmanship.
- 1.1 When product is applied according to Longboard Instructions and properly maintained, such product is guaranteed against the following:
 1.2 Buckling: The product itself will be free of any buckling that is not associated with the substrate and/or structure to which the Longboard system is attached. For the purpose of this warranty, buckling shall be defined as warping of the product(s) exceeding one sixteenth of an inch out of plane per linear foot.
 1.3 Corrosion: When installed in normal atmospheric conditions according to Longboard Instructions and properly maintained, such product is further guaranteed against rusting and corroding. Subject to the limitations set out in Clause 3 and 4.
 1.4 What we will do: If, during the fifteen (15) year Limited Warranty Period on the powder coating finish, the Product is defective in material or workmanship, Longboard will, in its sole discretion, either repair or replace the defective portion of the Product.
 1.5 What we will do: If, during the fifty (50) year Limited Warranty Period on the extruded aluminum profiles, the Product is defective in material or workmanship, Longboard will, in its sole discretion, either repair or replace the defective portion of the Product.
 1.6 After the 15th year, this Limited Warranty on the powder coated finish will expire and shall no longer be applicable.
 1.7 After the 50th year, this Limited Warranty on the aluminum extruded profile(s) will expire and shall no longer be applicable.
 1.8 Longboard replacement of the defective Product or reimbursement of this Limited Warranty is the exclusive remedy for the Covered Person for any defect in materials or workmanship. The Company will pay for all reasonable costs including material and labor as it relates to the repair and/or replacement of the defective Product.
- Clause 2**
 Product Finish - AAMA 2604 Performance Specification
- 2.1 During the first fifteen (15) years of this warranty:
 2.2 Checking/Cracking: No visible checking or cracking of the product finish on the building.
 2.3 Chalking Resistance: No chalking of the product finish on the building in excess of that represented by No.8 rating based on ASTM D4214.
 2.4 Color Retention: No color change of the product finish on the building greater than 5 (five) CIE Lab Δ E units calculated in accordance with ASTM 2244 Section 6.3. Color change shall be measured on the exposed paint surface which has been cleaned of oil, grease, chalk, oxidized film or other contaminants, corresponding values shall be measured on the control panel.
 2.5 Gloss Retention: Coated surface will exhibit gloss retention of a minimum of 30% of the original. Gloss retention shall be measured on the exposed paint surface which has been cleaned of oil, grease, chalk, oxidized film or other contaminants, corresponding values shall be measured on the control panel.
- 2.6 Adhesion: Adhesion of product finish when initially applied to test panels and measured by reference to AAMA 2604-02 Clause 7.4.2 will show no removal of the film.
- Clause 3**
- 3.1 Warranty Terms and Conditions:
 3.2 The "Warranty Period" for the warranties in Clause 1 shall mean the respective number of years or for as long as the Covered Person commencing on the date of substantial completion named above shall live and own the property on which the material was originally installed.
 3.3 Registration of the product is required within ninety (90) days from substantial completion for the warranty to be in effect. This warranty is valid for the original owner and one other subsequent owner of the structure where the product(s) have been installed.
 3.4 Normal atmospheric conditions exclude corrosive or aggressive atmospheres such as those contaminated with chemical fumes or other corrosive elements. The product finish is not meant for marine use on boats, ships or offshore platforms.
 3.5 The product finish warranties as outlined in Clause 2 shall include coverage of the finish as it relates to the impact effects from hail and woodpecker birds.
 3.6 Under no circumstance shall Longboard's liability under this limited warranty exceed 2.5 times the total corresponding Longboard material cost (excluding sales tax, labor and installation related costs) as noted on the original purchase invoice and paid by the Buyer for the specific project.
- Clause 4**
- 4.1 This warranty will not extend or cover:
 4.2 Damages to the coated metal caused by handling, shipping, processing and/or installation; or
 4.3 Damages to the coated metal caused by scratching or abrading after installation; or
 4.4 Damages to the coated metal as a result of standing water in horizontal installations.
 4.5 The warranty will not be applicable to damage or failure, which is caused by acts of God, falling objects, external forces, explosions, fire, riots, civil commotion's, acts of war, or other such similar or dissimilar occurrences beyond The Company's control.
 4.6 Customer shall make available to The Company the dates of the installation of the coated metal, the maintenance records including details of washing and cleaning procedures in compliance with the cleaning requirements as stated in the Required Maintenance section of this warranty. Customers shall demonstrate that the failure of the coated metal was due to a breach of the warranty stated herein.
 4.7 Claims must be made in writing to Longboard within 30 days of the discovery of a problem and authorization obtained prior to beginning any repair and/or refinishing work.
- 4.8 Longboard exclusive liability under this warranty, or otherwise, will be limited to refinishing and/or repairing, at The Company's sole discretion, the defective powder coated product. The warranty on any refinished, repaired or replaced coated metal supplied hereunder shall be for the remainder of the warranty period applicable to the originally coated metal. All warranty work will be performed by a company or contractor selected by Longboard. Color variance between refinished and/or repainted product and original shall not be indicative of a defect.
 4.9 This warranty represents the entire agreement between parties in relation to its subject matter and supersedes any previous agreement whether written or oral between the parties in relation to its subject matter. The limited warranties state the entire liability of Longboard with respect to the products covered by them. The Company shall have no liability for any incidental or consequential damages. No person is authorized to make any representation or warranty on behalf of Longboard except as expressly set forth above, and any such statement shall not be binding on The Company. Except as expressly set forth above, Longboard makes no warranty of any kind, express or implied, including, without limitation, any implied warranty of merchantability or fitness for a particular purpose. Warranties shall be the duration of the limited warranty, or such shorter duration as provided under applicable local law. These limited warranties give you specific legal rights, and you may also have other rights which vary from area to area.
 4.10 Nothing in this warranty shall be construed as a warranty of the workmanship of any installer or as imposing on Longboard any liability for unsatisfactory performance caused by faulty workmanship in installation.
 4.11 It's agreed all parties involved that all claims and disputes relating to this agreement that cannot be settled through negotiation will try in good faith to first settle the dispute by mediation administered by the American Arbitration Association (Construction Industry Mediation Procedures) as a prelude to mandatory binding arbitration. Such binding arbitration is to be conducted and administered by the Construction Industry Arbitration Rules of the American Arbitration Association. Both seller and purchaser agree to share equally in the costs of both mediation and arbitration and that such binding arbitration will be the sole and final remedial action.
 4.12 Required Maintenance. Depending on the Project Environment, follow the maintenance schedule as outlined in the Longboard Care & Maintenance Guide. Use a soft sponge or cloth, water and mild detergent, non-abrasive soap with the pH range of 5-9 to clean the powder coated area of dirt, grime and other debris. Pressure washing and the use of harsh detergents or chemicals is not recommended. Include in your maintenance records the following: date, time, specific products used, name of maintenance person and their designation, maintenance company name and general condition of the powder coated finish.

I have read and agree to the terms of the Longboard® Product 15 year powder coated surface and 50 year aluminum extruded profile(s) warranty and acknowledge receipt of a copy of the Warranty Certificate.

Name of owner or contractor:

--

Date:

--

Signature:

--



Duly authorized on behalf of Longboard:

Name and designation:

--

Date:

--

Signature:

--

20 Year Non-Prorated Powder Coating Finish - 50 Year Non-Prorated Extruded Aluminum Profiles [Limited Warranty]
Warranty granted to (building owner):

--

Longboard Architectural Products Inc. ("Longboard," "The Company") products as identified by the Product Codes listed will conform to the standards set out in Clause 1 and Clause 2 of this Warranty, subject to the terms and conditions set out in Clause 3 and 4 of this Warranty.

Product codes: Product description:

Finish:	

Install contractor	
Project name	
Project address	
Address 2	Install start date
Date of substantial completion	

This Pinnacle Warranty is only valid for applications within Canada and USA. All applications outside of Canada and USA are required to contact Longboard for assistance.

- Clause 1**
Extruded Aluminum Profile(s) with Powder Coat Finish Longboard expressly warrants that its product line is free from manufacturing defects in material or workmanship.
- 1.1 When product is applied according to Longboard Instructions and properly maintained, such product is guaranteed against the following:
 - 1.2 Buckling: The product itself will be free of any buckling that is not associated with the substrate and/or structure to which the Longboard system is attached. For the purpose of this warranty, buckling shall be defined as warping of the product(s) exceeding one sixteenth of an inch out of plane per linear foot.
 - 1.3 Corrosion: When installed in normal atmospheric conditions according to Longboard Instructions and properly maintained, such product is further guaranteed against rusting and corroding. Subject to the limitations set out in Clause 3 and 4.
 - 1.4 What we will do: If, during the twenty (20) year Limited Warranty Period on the powder coating finish, the Product is defective in material or workmanship, Longboard will, in its sole discretion, either repair or replace the defective portion of the Product.
 - 1.5 What we will do: If, during the fifty (50) year Limited Warranty Period on the extruded aluminum profiles, the Product is defective in material or workmanship, Longboard will, in its sole discretion, either repair or replace the defective portion of the Product.
 - 1.6 After the 20th year, this Limited Warranty on the powder coated finish will expire and shall no longer be applicable.
 - 1.7 After the 50th year, this Limited Warranty on the aluminum extruded profile(s) will expire and shall no longer be applicable.
 - 1.8 Longboard replacement of the defective Product or reimbursement of this Limited Warranty is the exclusive remedy for the Covered Person for any defect in materials or workmanship. The Company will pay for all reasonable costs including material and labor as it relates to the repair and/or replacement of the defective Product.
- Clause 2**
Product Finish - AAMA 2605 Performance Specification
- 2.1 During the first twenty (20) years of this warranty:
 - 2.2 Checking/Cracking: No visible checking or cracking of the product finish on the building.
 - 2.3 Chalking Resistance: No chalking of the product finish on the building in excess of that represented by No.8 rating based on ASTM D4214.
 - 2.4 Color Retention: No color change of the product finish on the building greater than 5 (five) CIE Lab Δ E units calculated in accordance with ASTM 2244 Section 6.3. Color change shall be measured on the exposed paint surface which has been cleaned of oil, grease, chalk, oxidized film or other contaminants, corresponding values shall be measured on the control panel.
 - 2.5 Gloss Retention: Coated surface will exhibit gloss retention of a minimum of 50% of the original. Gloss retention shall be measured on the exposed paint surface which has been cleaned of oil, grease, chalk, oxidized film or other contaminants, corresponding values shall be measured on the control panel.
- Clause 3**
- 3.1 Warranty Terms and Conditions:
 - 3.2 The "Warranty Period" for the warranties in Clause 1 shall mean the respective number of years or for as long as the Covered Person commencing on the date of substantial completion named above shall live and own the property on which the material was originally installed.
 - 3.3 Registration of the product is required within ninety (90) days from substantial completion for the warranty to be in effect. This warranty is valid for the original owner and one other subsequent owner of the structure where the product(s) have been installed.
 - 3.4 Normal atmospheric conditions exclude corrosive or aggressive atmospheres such as those contaminated with chemical fumes or other corrosive elements. The product finish is not meant for marine use on boats, ships or offshore platforms.
 - 3.5 The product finish warranties as outlined in Clause 2 shall include coverage of the finish as it relates to the impact effects from hail and woodpecker birds.
 - 3.6 Under no circumstance shall Longboard's liability under this limited warranty exceed 2.5 times the total corresponding Longboard material cost (excluding sales tax, labor and installation related costs) as noted on the original purchase invoice and paid by the Buyer for the specific project.
- Clause 4**
- 4.1 This warranty will not extend or cover:
 - 4.2 Damages to the coated metal caused by handling, shipping, processing and/or installation; or
 - 4.3 Damages to the coated metal caused by scratching or abrading after installation; or
 - 4.4 Damages to the coated metal as a result of standing water in horizontal installations.
 - 4.5 The warranty will not be applicable to damage or failure, which is caused by acts of God, falling objects, external forces, explosions, fire, riots, civil commotion, acts of war, or other such similar or dissimilar occurrences beyond The Company's control.
 - 4.6 Customer shall make available to The Company the dates of the installation of the coated metal, the maintenance records including details of washing and cleaning procedures in compliance with the cleaning requirements as stated in the Required Maintenance section of this warranty. Customers shall demonstrate that the failure of the coated metal was due to a breach of the warranty stated herein.
 - 4.7 Claims must be made in writing to Longboard within 30 days of the discovery of a problem and authorization obtained prior to beginning any repair and/or refinishing work.
- Clause 4.8**
The claimant must provide proof of coverage. Claims can be made by writing to Longboard at the Product Performance Department. After receiving such notice, The Company must be given a reasonable opportunity to inspect and verify the claim. Longboard exclusive liability under this warranty, or otherwise, will be limited to refinishing and/or repairing, at The Company's sole discretion, the defective powder coated product. The warranty on any refinished, repaired or replaced coated metal supplied hereunder shall be for the remainder of the warranty period applicable to the originally coated metal. All warranty work will be performed by a company or contractor selected by Longboard. Color variance between refinished and/or repainted product and original shall not be indicative of a defect.
- Clause 4.9**
This warranty represents the entire agreement between parties in relation to its subject matter and supersedes any previous agreement whether written or oral between the parties in relation to its subject matter. The limited warranties state the entire liability of Longboard with respect to the products covered by them. The Company shall have no liability for any incidental or consequential damages. No person is authorized to make any representation or warranty on behalf of Longboard except as expressly set forth above, and any such statement shall not be binding on The Company. Except as expressly set forth above, Longboard makes no warranty of any kind, express or implied, including, without limitation, any implied warranty of merchantability or fitness for a particular purpose. Warranties shall be the duration of the limited warranty, or such shorter duration as provided under applicable local law. These limited warranties give you specific legal rights, and you may also have other rights which vary from area to area.
- Clause 4.10**
Nothing in this warranty shall be construed as a warranty of the workmanship of any installer or as imposing on Longboard any liability for unsatisfactory performance caused by faulty workmanship in installation.
- Clause 4.11**
It's agreed all parties involved that all claims and disputes relating to this agreement that cannot be settled through negotiation will try in good faith to first settle the dispute by mediation administered by the American Arbitration Association (Construction Industry Mediation Procedures) as a prelude to mandatory binding arbitration. Such binding arbitration is to be conducted and administered by the Construction Industry Arbitration Rules of the American Arbitration Association. Both seller and purchaser agree to share equally in the costs of both mediation and arbitration and that such binding arbitration will be the sole and final remedial action.
- Clause 4.12**
Required Maintenance. Depending on the Project Environment, follow the maintenance schedule as outlined in the Longboard Care & Maintenance Guide. Use a soft sponge or cloth, water and mild detergent, non-abrasive soap with the pH range of 5-9 to clean the powder coated area of dirt, grime and other debris. Pressure washing and the use of harsh detergents or chemicals is not recommended. Include in your maintenance records the following: date, time, specific products used, name of maintenance person and their designation, maintenance company name and general condition of the powder coated finish.

I have read and agree to the terms of the Longboard® Product 20 year powder coated surface and 50 year aluminum extruded profile(s) warranty and acknowledge receipt of a copy of the Warranty Certificate.

Name of owner or contractor:

--

Date:

--

Signature:

--

Duly authorized on behalf of Longboard:
Name and designation:

--

Date:

--

Signature:

--