



LONGBOARD®
INSPIRING ARCHITECTURE

Link & Lock™ Cladding

Installation Guidelines

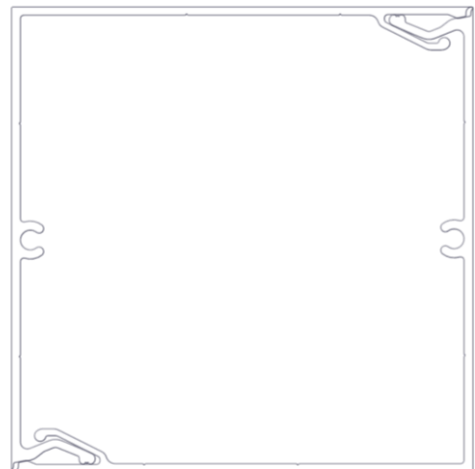
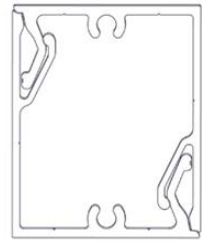
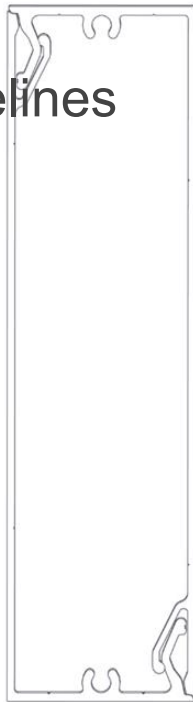

Table of Contents

Critical Details	3
Material Specifications	4
Finishes	4
Expansion and contraction	4
Material ordering and deliveries	4
Storage and handling	4
Cleaning	4
Warranty	4
Graffiti Removal	5
Components	6
Components (Typical)	6
Tools/Cutting/Fastening	7
Tools	7
Cutting	7
Fastening	8
Fastener types	8
Framing/Furring requirements	9
System Install	10
Install details	10
Typical dimensions	10
System layout and Install steps	11
Perimeter and field area limitations	11
Cantilever limits	11
Preparation drilling for Install	12
Butt-Joints & Lap Joints	13
Batten orientation	14-15
Fin orientation	16
End to End orientation (End Mounts)	17-18
Large spans with Stiffener	19-21
Link & Lock HD	22
4x4 & 4x6 Link & Lock	23
Link & Lock Brackets	24-28
Appendix	29
Tables 1 & 2 - Expansion & contraction	29
Tables 3-9 - Allowable Attachment Span	30-35
Handling and care of products	36
Blank Page	37
Contact Info	38

CRITICAL DETAILS

CUT TAPED/DRILLED ENDS

CUT Factory Ends.

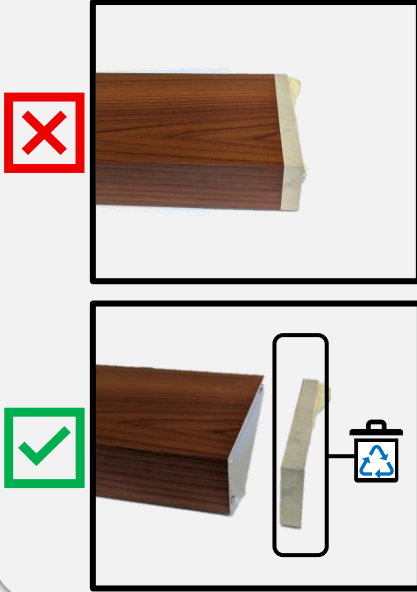

LAP JOINTS & THERMAL MOVEMENT¹

Overlap L&L joints min 2ft.

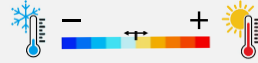

THERMAL CALCULATOR DOWNLOAD¹

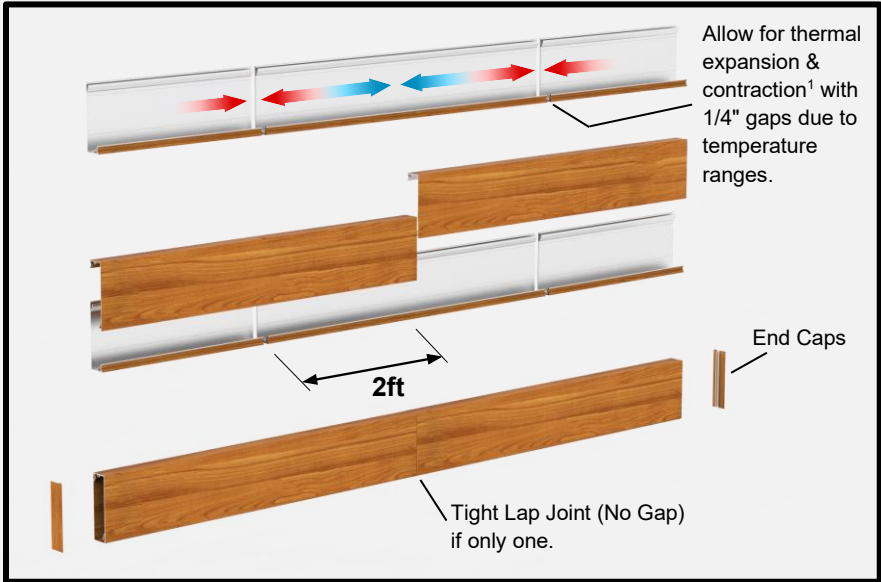

FASTENERS

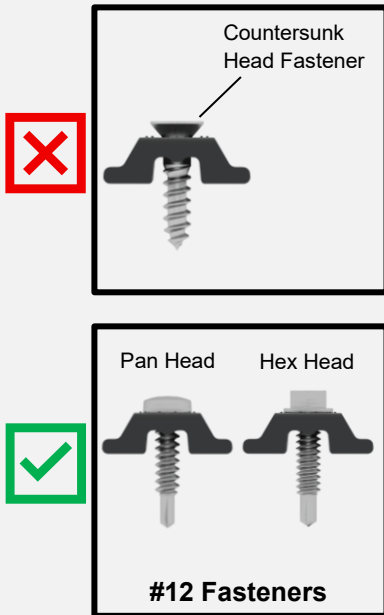

HARD FASTENER

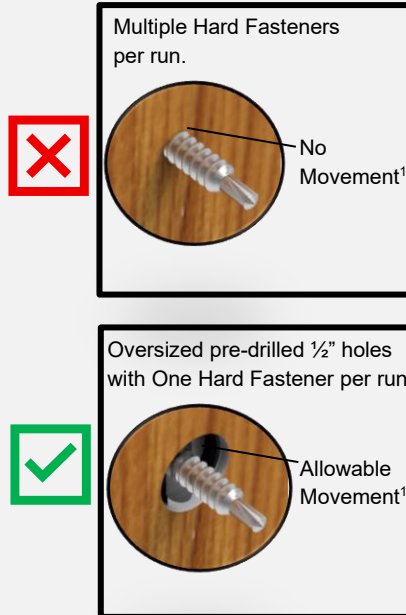

CANTILEVER

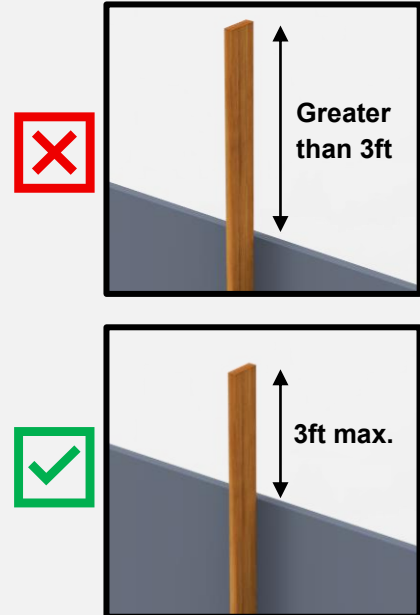

! Note 1: We recommend calculating the site specific temperature ranges for thermal expansion & contraction values.

Material Specifications

Finishes

- Longboard Products are available in a wide range of powder coated finishes
- Custom solid colors are available upon request

Longboard extruded products are produced 1" (25mm) oversized, as one end is drilled for the coating process and both ends have 1/2" (12mm) of masking tape (woodgrains only) which must be cut off for best results.

Expansion & Contraction

Link & Lock components expand & contract 1/4" (6mm) over 24' (7.3m) along the length, measured over a 30°C (54°F) temperature range. Due to this range of movement, Link & Lock Fins/Louvers/Battens should be installed with staggered butt-joints, leaving a 1/4" (6mm) min. gap, every 24' (7.3m) min. Alternatively, staggered lap-joints are an option for a continuous appearance, however 1/4" (6mm) gaps should be left at each joint to allow for thermal movement. Be sure to lap joints by 2' (610mm) minimum over the back "L". See **Appendix for Tables 1 & 2, expansion/contraction calculations per foot/meter of material.**

Material Ordering & Delivery

- | | |
|--------------|---|
| • Packaging: | Link & Lock is sold by the set (pair) and in widths of 2", 4", 6", 8"
End caps are sold by the box: 20 caps/bx
End Mounts are sold by the box: 20 mounts/bx
Stiffener is sold in 24' lengths (includes Double-sided Tape) |
| • Shipping: | Delivered on 24' (7.3m) long skids weighing up to 2000 lbs. A mechanical lift with forks is required on site to receive the order. |
| • QC: | Always inspect the delivery for damage and contact LB ASAP if there are any issues: info@longboardproducts.com or 1-800-604-0343 and include your PO# and any pictures if possible. Mark the delivery receipt as "damaged" and accept the delivery as-is. Longboard is not responsible for the installation of blemished or damaged material. |

Storage & Handling

Be sure to store the material flat, keep it dry, safe & secure and remain in unopened cartons until ready to be installed. See **Appendix for proper handling and care instructions.**

Cleaning Recommendations

- Initial and periodic cleaning for best looking product
- Basic methods use a combination of moderate water pressure, soft sponge/brush and a mild detergent (Safe for your hands, safe for the product)

⚠ NEVER use aggressive, acid or alkaline cleaners on Longboard finishes. Do not use cleaners containing Trisodium Phosphate, Phosphoric Acid, Hydrochloric Acid, Hydrofluoric Acid, Fluorides, or any other compound that is known to react with metal.

See *Cleaning Guide for full requirements & cleaning schedule:
longboardproducts.com/resources/care-maintenance.com

Warranty

Upon substantial completion of the project, register for warranty online here: longboardproducts.com/warranty
Registration is required for the warranty to be in effect.

Graffiti Removal

Standard Woodgrain
 Use Standard soap & water only

D2000 Solid Color

	Prosoco Cleaner	MEK Solvent
Permanent Marker	<input checked="" type="checkbox"/>	<input checked="" type="checkbox"/>
Oil Based Spray Paint	<input checked="" type="checkbox"/>	<input checked="" type="checkbox"/>
Water Based Spray Paint	<input checked="" type="checkbox"/>	<input checked="" type="checkbox"/>
Adhesive Tape	<input checked="" type="checkbox"/>	<input checked="" type="checkbox"/>

MEK Solvent

Prosoco Anti-Graffiti Cleaner

SPECIAL ORDER - EXT. LEAD TIMES CONTACT LB

Anti-Graffiti High Gloss Woodgrain

	MEK Solvent
Permanent Marker	<input checked="" type="checkbox"/>
Oil Based Spray Paint	<input checked="" type="checkbox"/>
Water Based Spray Paint	<input checked="" type="checkbox"/>
Adhesive Tape	<input checked="" type="checkbox"/>

MEK Solvent

Note: Cleaning the surface with a cleanser that is not diluted as per instructions may result in damage to the coating.

Components

Components (Typical)

The Link & Lock™ system consists of two (2) matching L-shaped extrusions, snapped together to make a complete set. For all LB components go to longboardproducts.com.

Link & Lock™ Battens

Size	12'	24'	End Caps (20/box)	End Mounts (20/box)
2"	2X2LL.145	2X2LL.289	2LLEC.2	2LLEM.2
4"	2X4LL.145	2X4LL.289	2LLEC.4	2LLEM.4
6"	2X6LL.145	2X6LL.289	2LLEC.6	2LLEM.6
8"	2X8LL.145	2X8LL.289	2LLEC.8	2LLEM.8

Link & Lock™ HD Battens

4"	2X4LLHD.145	2X4LLHD.289	2LLHDEC.4	2LLHDEM.4
6"	2X6LLHD.145	2X6LLHD.289	2LLHDEC.6	2LLHDEM.6
8"	2X8LLHD.145	2X8LLHD.289	2LLHDEC.8	2LLHDEM.8

Link & Lock™ Box Battens

4 x 4"	4X4LL.145	4X4LL.289	4LLEC.4	-
4 x 6"	4X6LL.145	4X6LL.289	4LLEC.6	-



Mounting Accessories	Qty	SKU
Link & Lock Mounting Clip	48, bag	LLMC.N48
Link & Lock™ Isolation Washer	48, bag	LLIW.N48
Dewalt® 1/2" Pilot Point Drill Bit	1	DRILLBT.05
24' Link & Lock Internal Stiffener	1	LLSTIFF.289
3M® Double Sided Adhesive Tape - 108'	1, roll	LLTAPE.1296



Link & Lock™ Mounting Brackets



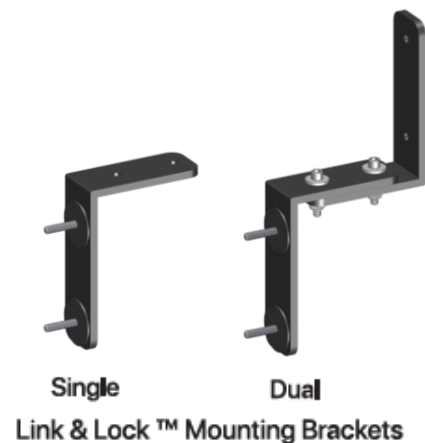



Product	Single	Dual
45° LEFT FIXED	LLMBK.45LF	LLDMBK.45LF
45° RIGHT FIXED	LLMBK.45RF	LLDMBK.45RF
90° CENTER FIXED	LLMBK.90F	LLDMBK.90F
45° LEFT SLIDING	LLMBK.45LS	LLDMBK.45LS
45° RIGHT SLIDING	LLMBK.45RS	LLDMBK.45RS
90° CENTER SLIDING	LLMBK.90S	LLDMBK.90S

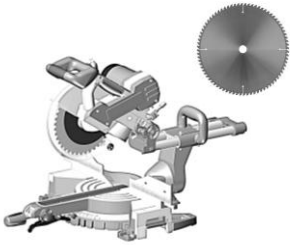

Tools/Cutting/Fastening

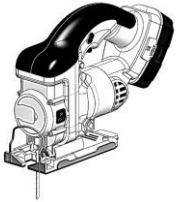
Tools

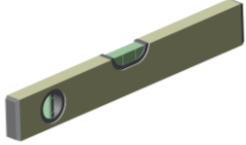
Commonly used tools for Link & Lock install.

			
Table Saw with Carbide Metal Blade Non-ferrous 60-80T (for cutting aluminum)	Miter Saw with Carbide Metal Blade Non-ferrous 60-80T (for cutting aluminum)	Cordless Drill with clutch	Jig Saw (for protrusions)
			
Rubber Mallet (or Hammer)	Level	Hole Saw (for lighting fixtures)	Quick Grip Bar Clamp

Cutting

⚠ Always be sure to wear appropriate PPE: eye & hearing protection.

Cut battens using a Miter Saw and Table Saw always allowing for expansion & contraction. Trim the taped/drilled ends of all stock length material by at least **1/2" (12mm) each end** and discard.

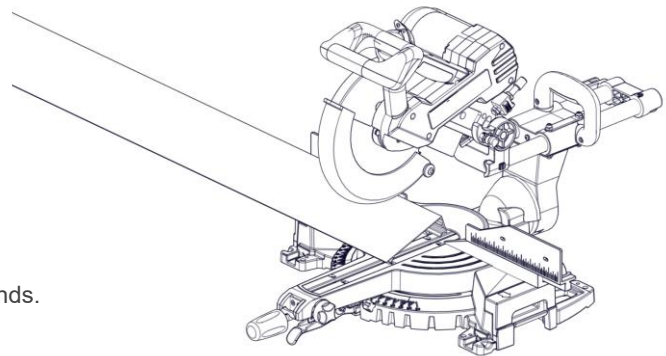

DO NOT Install Link & Lock without trimming the ends.

Fastening

⚠ Always consult the project engineer, architect or authority having jurisdiction to understand the project specific fastening requirements.

Typical Spacing:

- 6 - 8' O.C.

-using **Mounting Clips** and **Isolation Washers**

-See **Appendix Tables 3-9** for project specific spacing.

Mounting Clips and Isolation Washers are included in the order for 6' spacings. Add more to the order if required for shorter spacings.

Fasteners:

See fastener sizes below (By others)

Layout and predrill the back "L" at all fastener locations.

Refer to **Preparation drilling for Install** for hole dimensions and further details.

See **Appendix for fastener specs:**

Allowable Span - Tables 3-9

Fastener Types/Sizes for L&L		
L&L	Pan Head	Hex Head
2"	#12	#12
4"	#12	#12
6"	#12	#12
8"	#12	#12
4"x4"	#12	#12
4"x6"	#12	#12
4" HD	#14	#14
6" HD	#14	#14
8" HD	#14	#14

Fastener types

RECOMMENDED

Pan-Head Rounded-Head Self-Drilling Flanged Hex Head



*Length, thread and point to suit substrate and material surface.

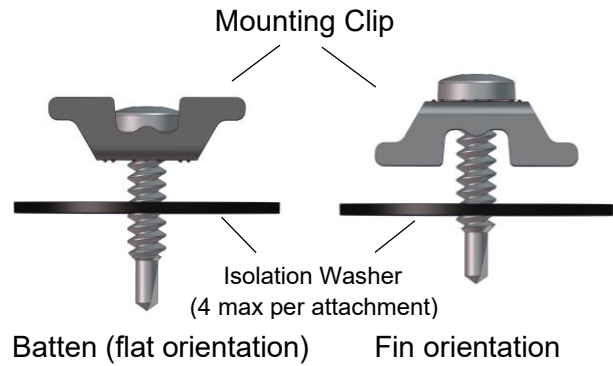

DO NOT USE

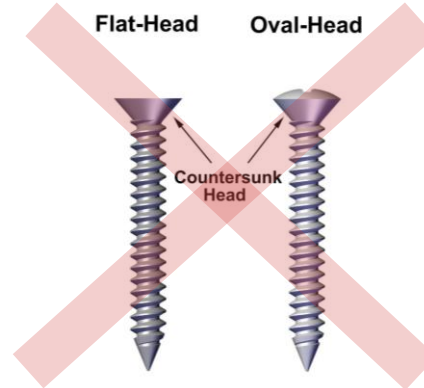

Fastener Types/Sizes for End Mounts		
End Mount	Pan Head	Hex Head
2"	#10	X
4"	#12	#12
6"	#12	#12
8"	#12	#12
4" HD	#14	#14
6" HD	#14	#14
8" HD	#14	#14

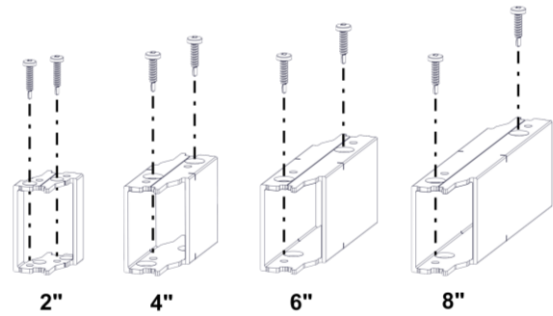

Framing/Furring requirements

Always consult your local building authority and follow local building code requirements. See Typical dimensions for sizes and weights of the L&L system.

See **Appendix for framing/furring/sheathing specs: Tables 3-9**

System Install

Install details

Typical dimensions

- Longboard Link & Lock system typical dimensions:

L&L	Width	Depth	Length	Weight(lbs/LF) *per set
2"	2" (50.8mm)	1 5/8" (41.3mm)	12'/24'	0.93
4"	4" (101.6mm)	1 5/8" (41.3mm)	12'/24'	1.3
6"	6" (152.4mm)	1 5/8" (41.3mm)	12'/24'	1.6
8"	8" (203mm)	1 5/8" (41.3mm)	12'/24'	1.9
4"x4"	4" (101.6mm)	4" (101.6mm)	12'/24'	1.8
4"x6"	6" (152.4mm)	4" (101.6mm)	12'/24'	2.1
4" HD	4" (101.6mm)	2" (50.8mm)	12'/24'	1.7
6" HD	6" (152.4mm)	2" (50.8mm)	12'/24'	2.4
8" HD	8" (203mm)	2" (50.8mm)	12'/24'	3

- Longboard Products are not recommended for use on marine applications in direct contact with salt water.
- Link & Lock is an open-joint system which is required to be installed outboard of a weather resistant barrier, including all flashings, following code, and building requirements.
- It is good practice to leave a 1/4" (6mm) gap between every component joint or 24' (7.3m) to allow for expansion & contraction. Consider the joints where components meet each other to dictate which component is installed first (eg: right angle butt joints, mitered joints etc.).
- Mounting Clips and Isolation Washers allow for movement of the battens, to expand & contract during thermal changes.
- Fasten Mounting Clips every 6-8' typical (based on project wind load requirements), alternating from top to bottom for battens using die lines for guides.

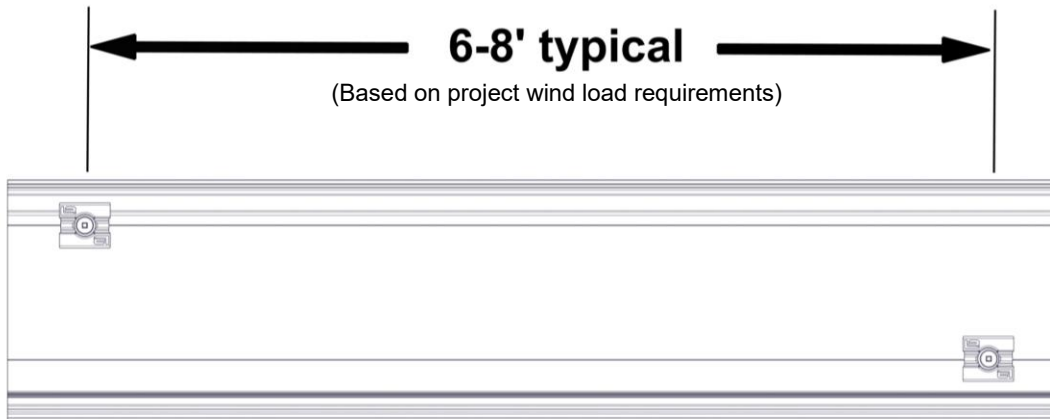

System layout and Install steps

Perimeter and field area limitations

Measure and layout your wall area to consider Link & Lock alignment with fixtures, penetrations, and adjacent walls, for desired appearance. The same methodology applies for vertical installations.

Seamless runs up to 24' length battens (no butt-joints)

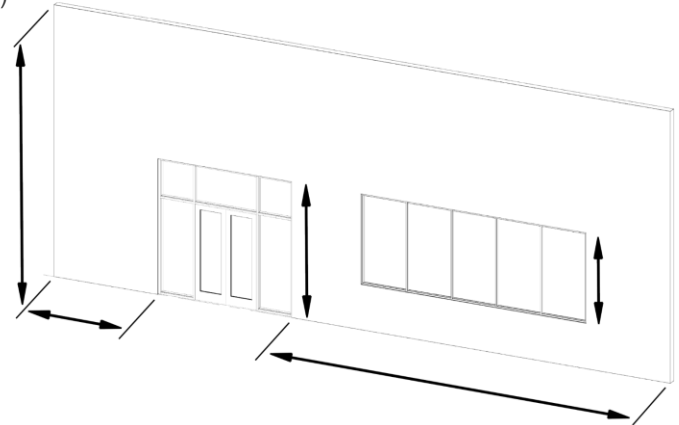
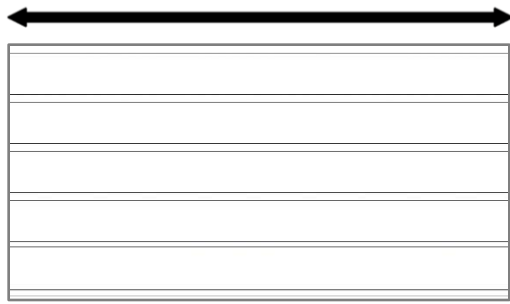

Runs with staggered butt-joints

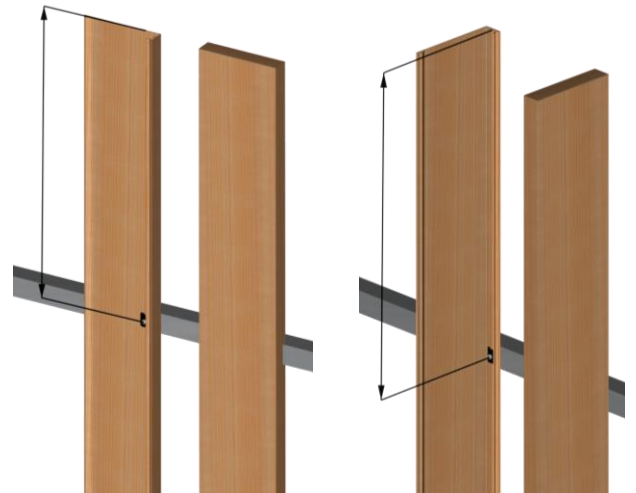
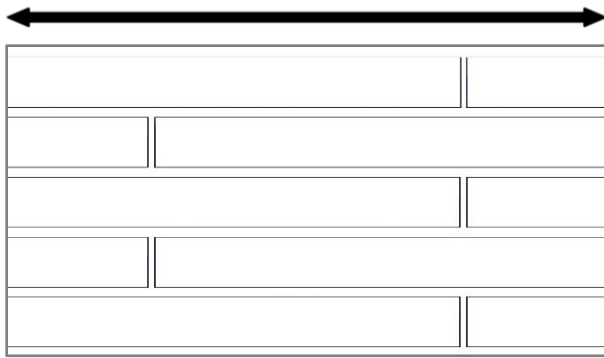

Runs with staggered lap-joints.

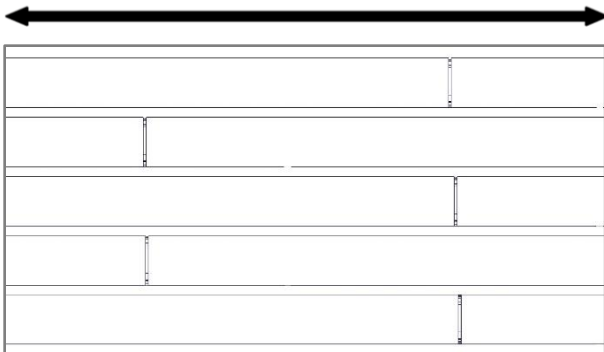

Link & Lock can cantilever half the allowable attachment span up to a **maximum of 3'** for all sizes and orientation. See Appendix for allowable attachment span:
Tables 3-9

Preparation drilling for Install

To prepare Link & Lock for install, layout and predrill the back "L" with 1/2" holes every 6-8' O.C. typical, with the first hole 2" in from the end to allow space for the End Cap.

For the Batten orientation, alternate the holes from top to bottom using the Dielines for guides.

For Fin orientation, use Pilot Point Drill Bit (see below) as recommended for ease of drilling.

Note: To hard fasten 1 location per length, omit the drilled hole at that location and use for hard fastening.

See **Appendix for project specific fastener spacing:**

Allowable Span - Tables 3-9

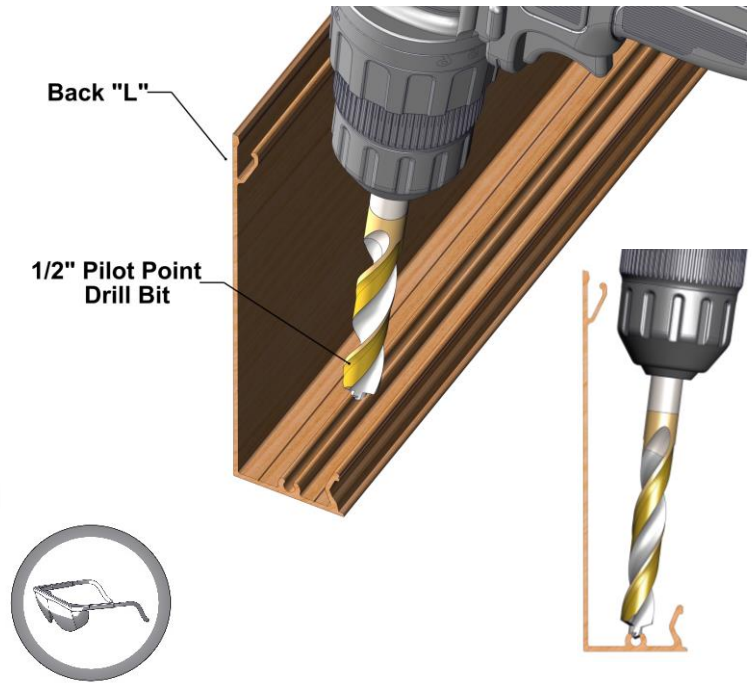
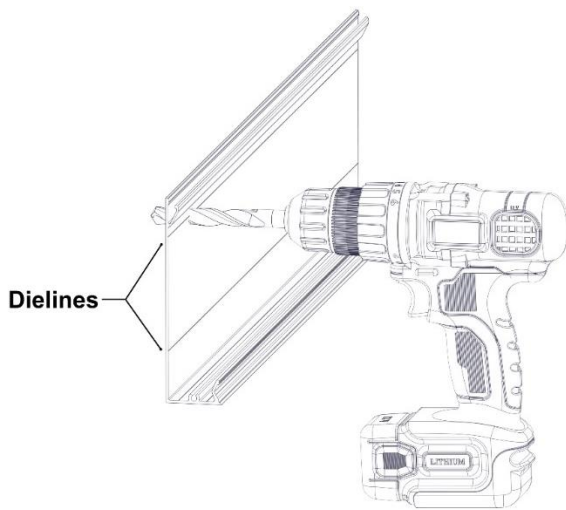
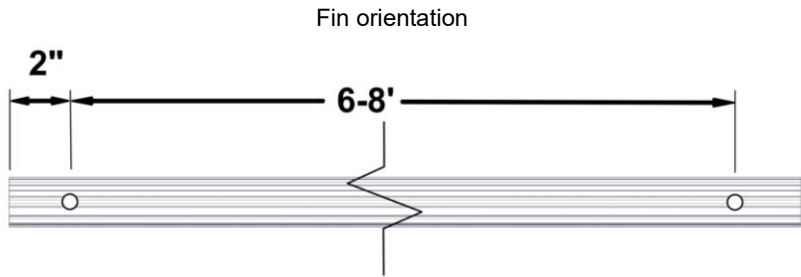
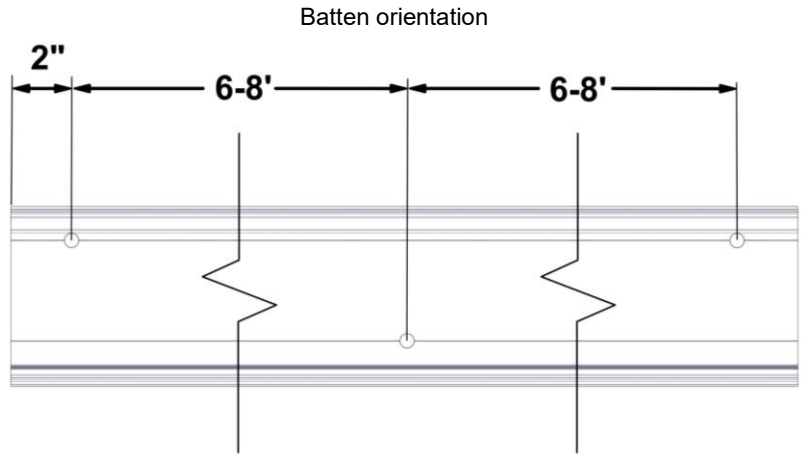

Butt-Joints & Lap Joints

- BUTT-JOINTS. When installing butt-joints, ensure to leave a 1/4" (6mm) min. gap. every 24' (7.3m) min. (**See Detail A**). Fasteners should be anchored into a solid secure framing member, blocking, furring strip, or backer plate, etc.
- LAP-JOINTS. When installing lap-joints, ensure to leave a 1/4" (6mm) min. gap. every 24' (7.3m) min. (**See Detail A**). Fasteners should be anchored into a solid secure framing member, blocking, furring strip, or backer plate, etc.
- If needed, use touch-up paint pens (purchased separately) to finish the ends at the butt-joint or lap-joint.
- It is good practice to hard-fasten each back "L" at one point per length typically near the center, to keep the battens from migrating.
- DO NOT hard-fasten more than one (1) location per batten.

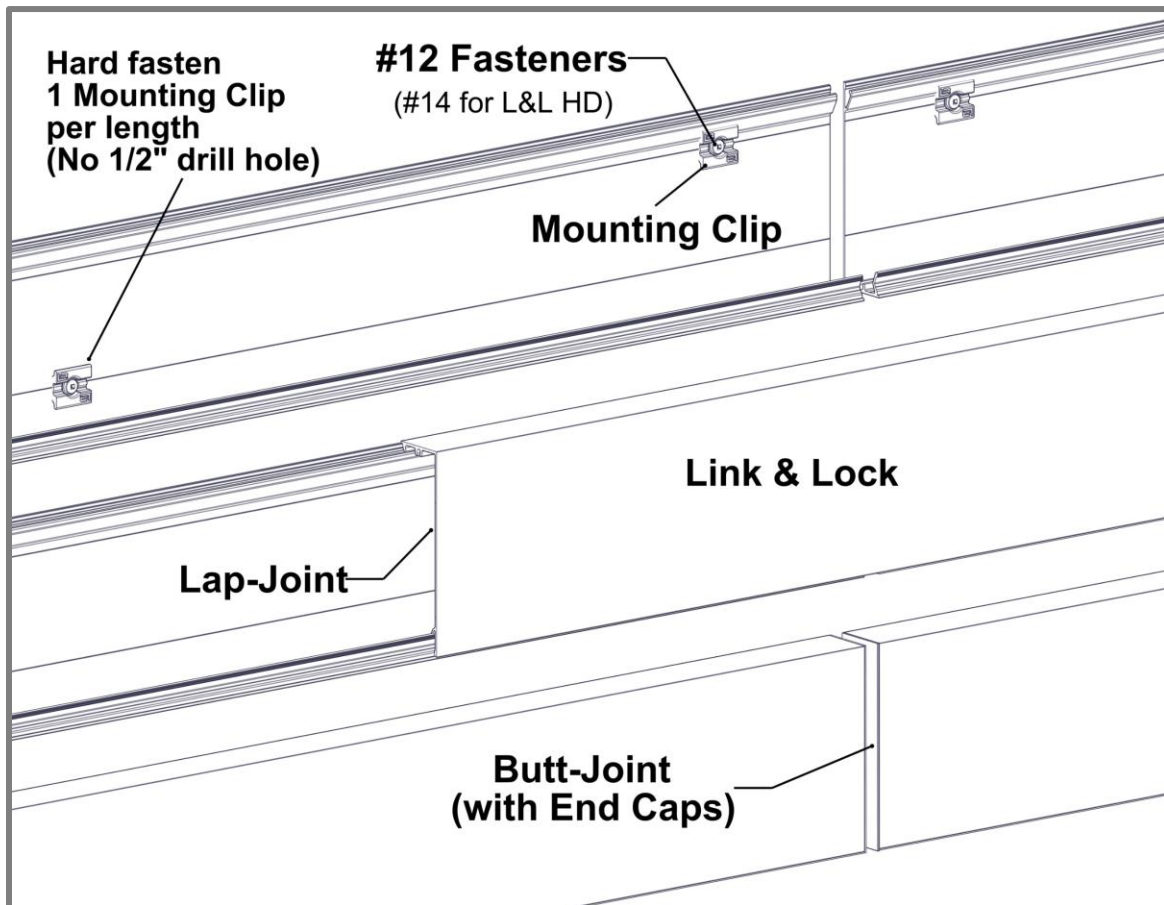

Detail A

Install Batten orientation

Step 1

Place predrilled Link & Lock back "L" into position (Drilling page). It is good practice to check your installation every 2-3 rows for level/plumb and flat/straight, for best results.

! Cut off Taped/Drilled L&L ends (1/2" each end).

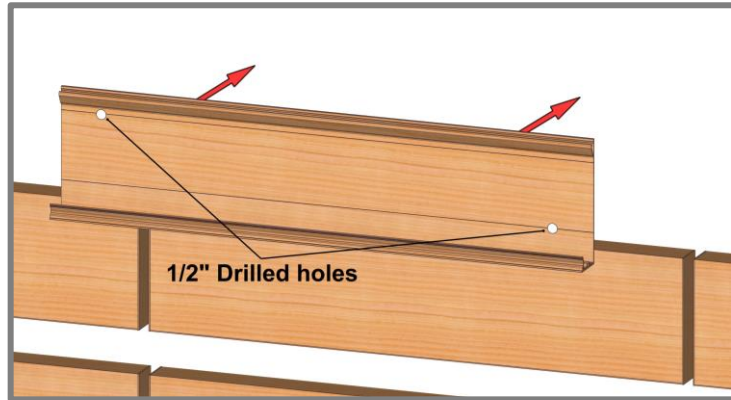

Step 2

Install back "L" using #12 Fasteners (#14 for L&L HD), Mounting Clips and Isolation Washers every 6-8' O.C. typical. Isolation Washers are installed between the L&L and the substrate (4 max per attachment).

Note: Be sure to fasten in the center of the 1/2" holes to allow for movement each way. Hard fasten near the center of each length to prevent migration of the material over time.

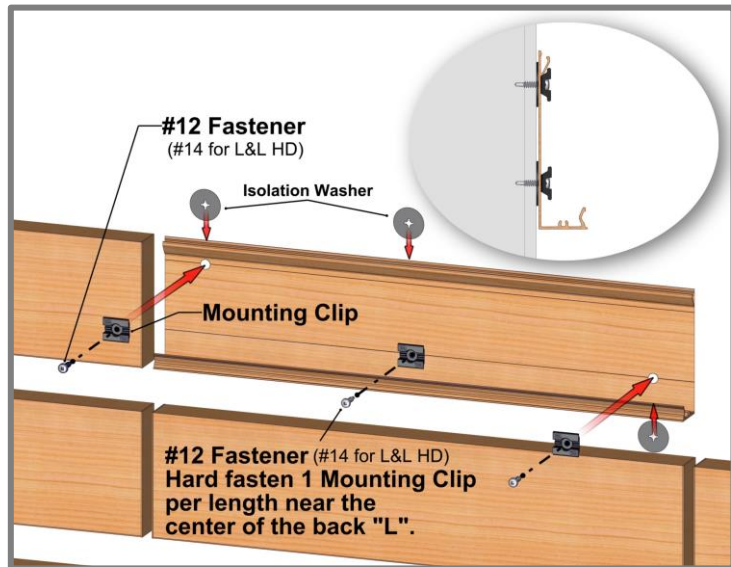

Step 3

Install front "L" and snap it into place, aligning it with ends and joints. If necessary, use a rubber mallet or hammer and block to protect the finish.

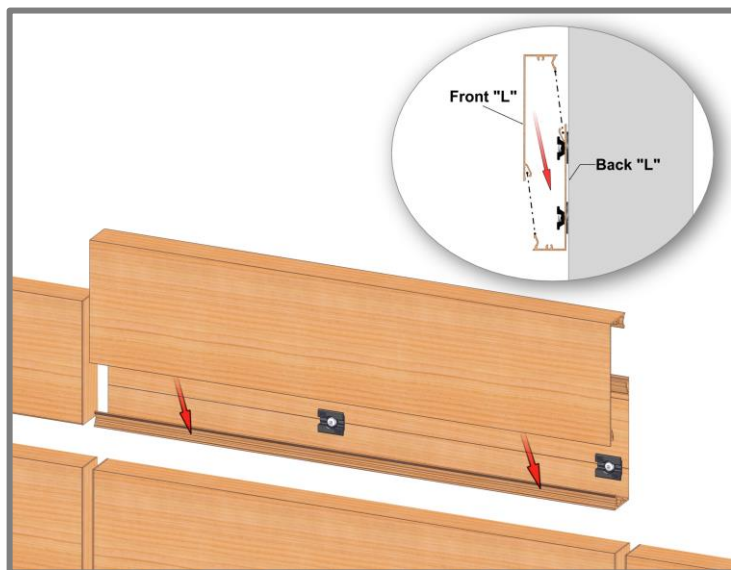

Step 3.1

Use clamps with rubber pads as common practice to securely snap the front "L" onto the back "L".

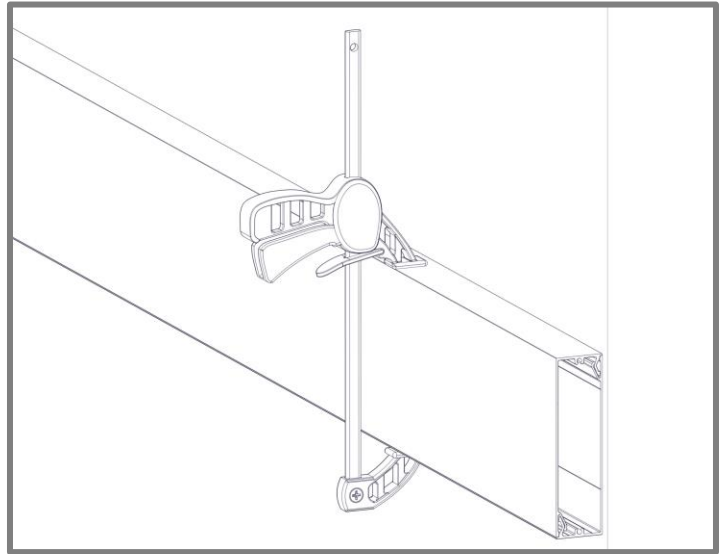

Step 4

Install End Caps, which are friction fit, by pressing them into place using the palm of your hand. If necessary, use a rubber mallet to snap them into place. See below images. Use paint pens to coat Link & Lock cut ends that may show slightly beyond the End Caps.

Consider your application sequence of the End Caps before installing adjacent Link & Lock members, as they may limit the space needed to insert the caps. In this situation you may need to install the caps first then the front "L" as seen in the image to the right.

TIP: Use shim to hold/secure cap while snapping in the front "L".

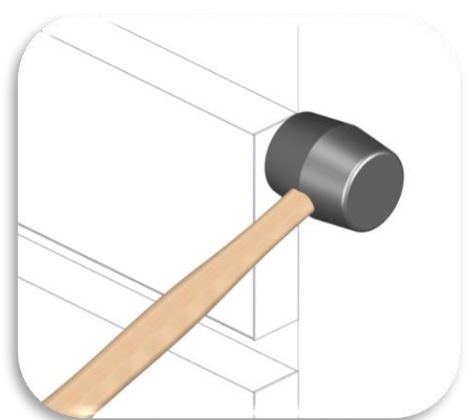
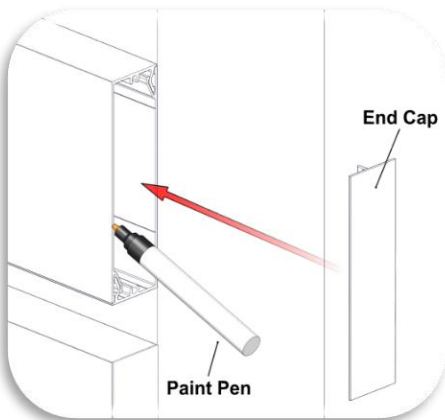
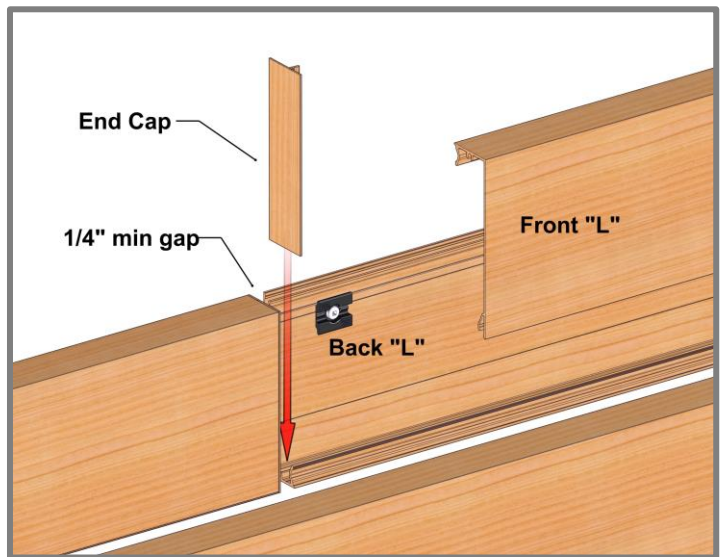

Install Fin orientation

Step 1

Place predrilled Link & Lock back “L” into position (See Drilling page). It is good practice to check your installation every 2-3 rows for level/plumb and flat/straight, for best results.

! Cut off Taped/Drilled L&L ends (1/2" each end).

Fin Orientation

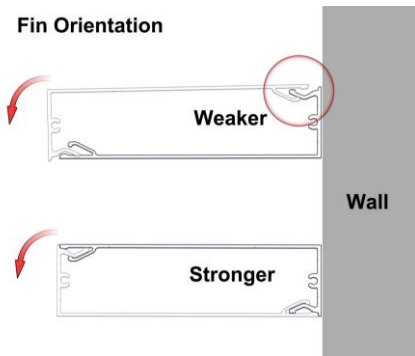

Step 2

Install back “L” using #12 Fasteners (#14 for L&L HD), Mounting Clips and Isolation Washers every 6-8' O.C. typical. Isolation Washers are installed between the L&L and the substrate (4 max per attachment).

Note: Be sure to fasten in the center of the 1/2" holes to allow for movement each way. Hard fasten near the center of each length to prevent migration of the material over time.

Step 3

Install front “L” and snap it into place, aligning it with ends and joints. If necessary, use a rubber mallet or hammer and block to protect the finish.

Step 4

Refer to the previous page for End Cap install and considerations.

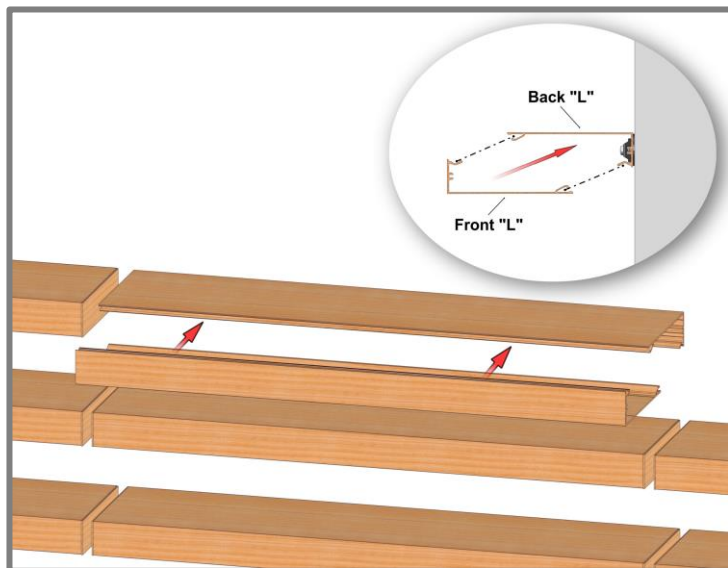
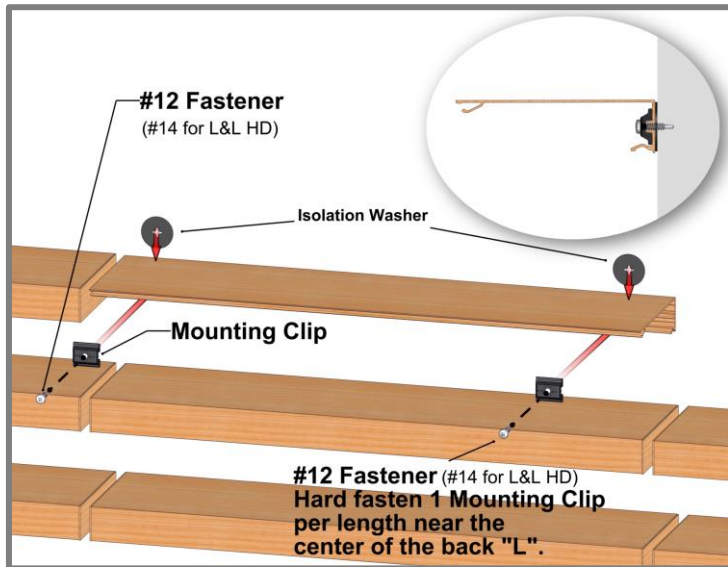
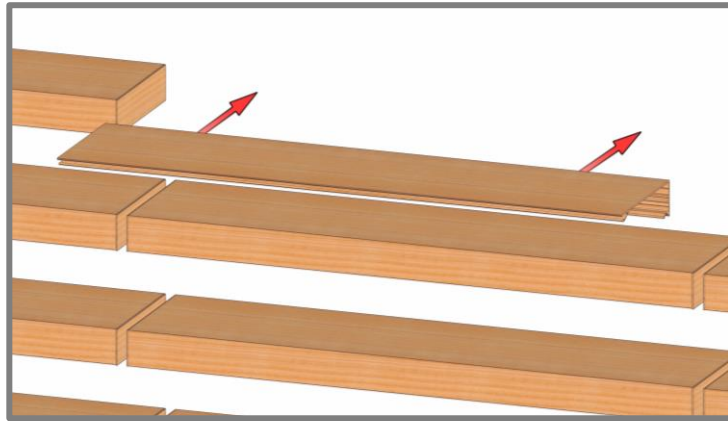

Install End to End orientation

Note: Use Tables 3-9 in Appendix for Allowable Span for Wind Loading.

Step 1

Place End Mounts into position at the top and bottom of the install. It is good practice to check your installation every 2-3 rows for level/plumb and flat/straight, for best results.

Fastener Types for End Mounts		
End Mount	Pan Head	Hex Head
2"	#10	#10
4"	#12	#12
6"	#12	#12
8"	#12	#12
4" HD	#14	#14
6" HD	#14	#14
8" HD	#14	#14

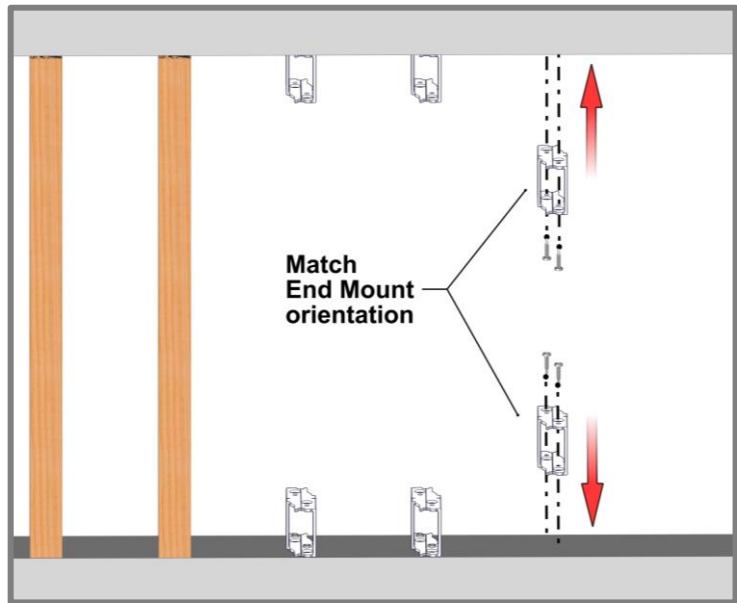

Step 2

Install the End Mounts using Fasteners (by others). Make sure to match the orientation of the End Mounts so the Link & Lock set matches on the top and the bottom. See above for **Fastener Types and sizing for End Mounts**.

! TIP: Check the position of the End Mounts once installed to allow a plumb and straight look.

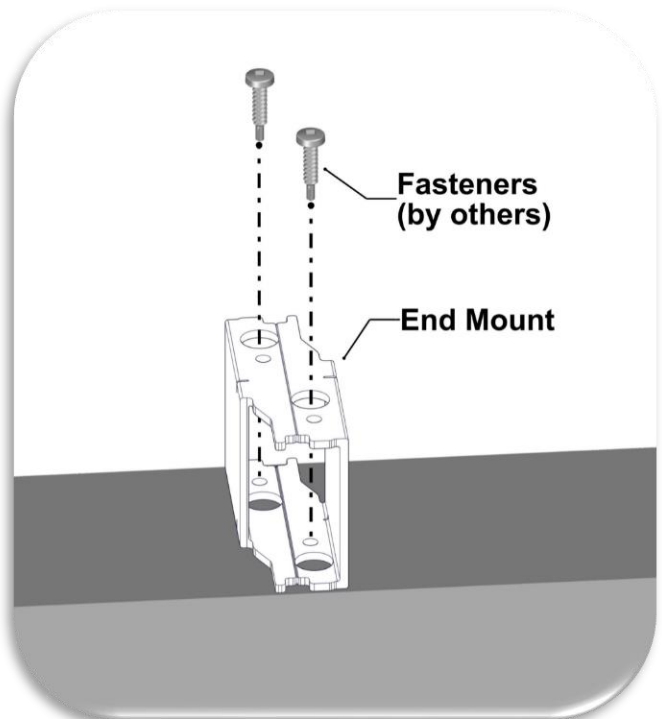
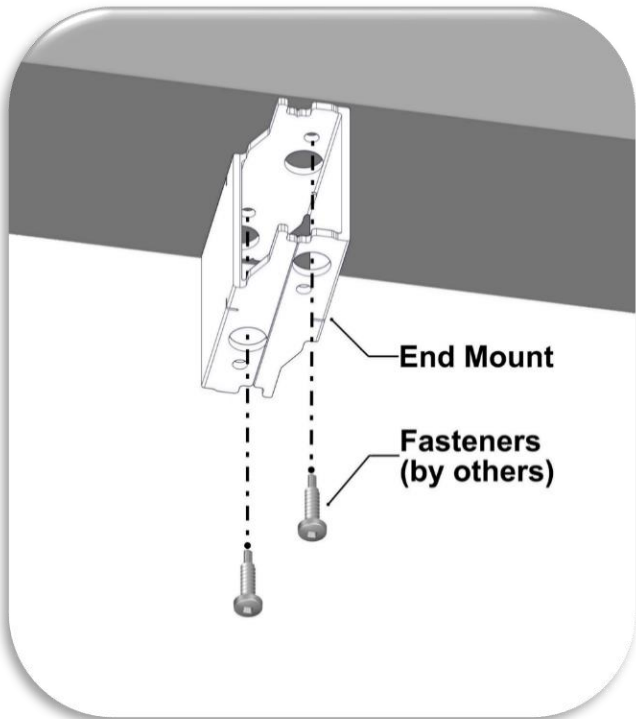

Step 3

Measure, cut and install Link & Lock Set and snap it into place onto the End Mounts. Use clamps with rubber pads as common practice to securely snap the front “L” onto the back “L”.

If necessary, use a rubber mallet or hammer and block to protect the finish.

! TIP: When measuring the Link & Lock, make sure to leave a gap (~1/4”) for expansion and building movement.

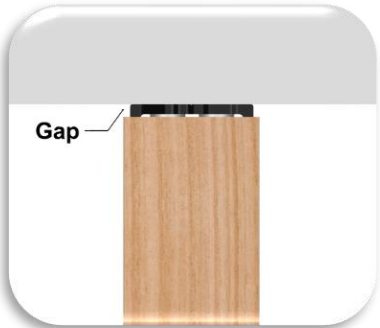

Cut off Taped/Drilled L&L ends (1/2" each end).

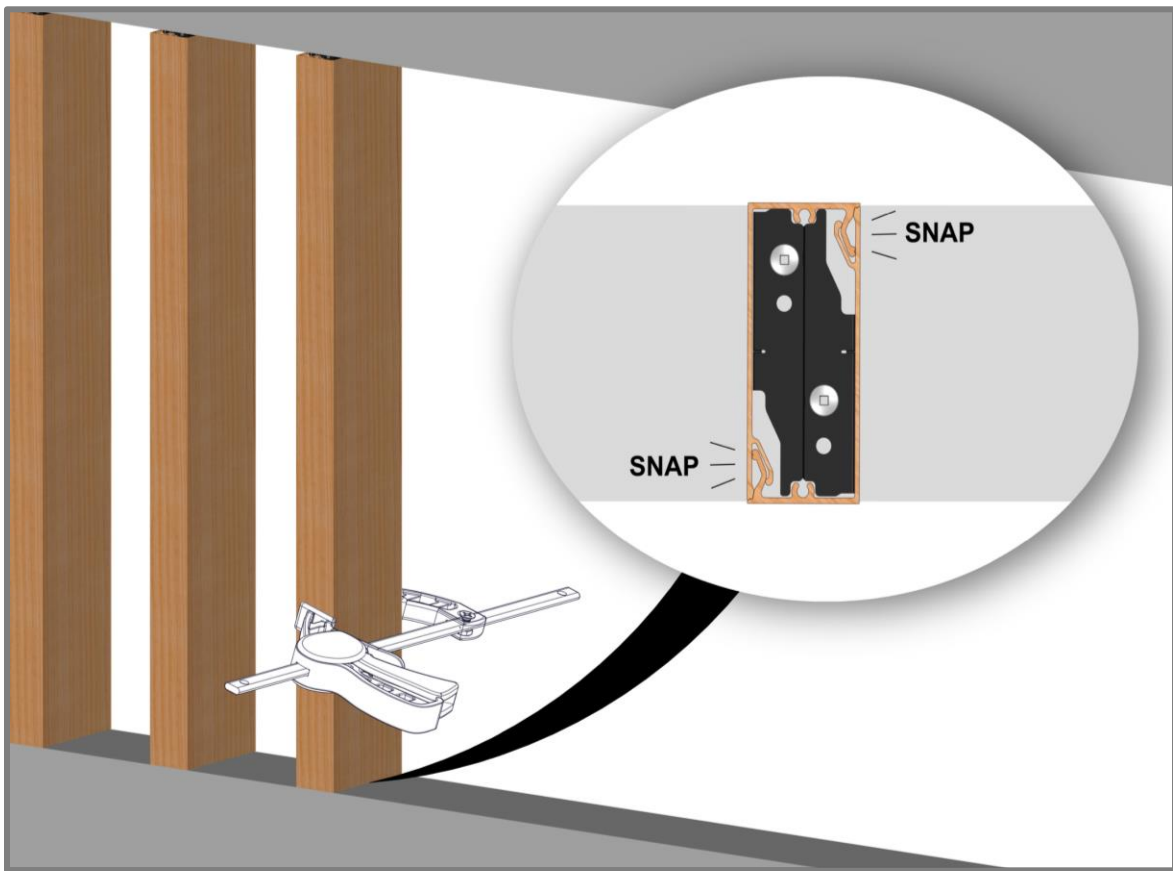
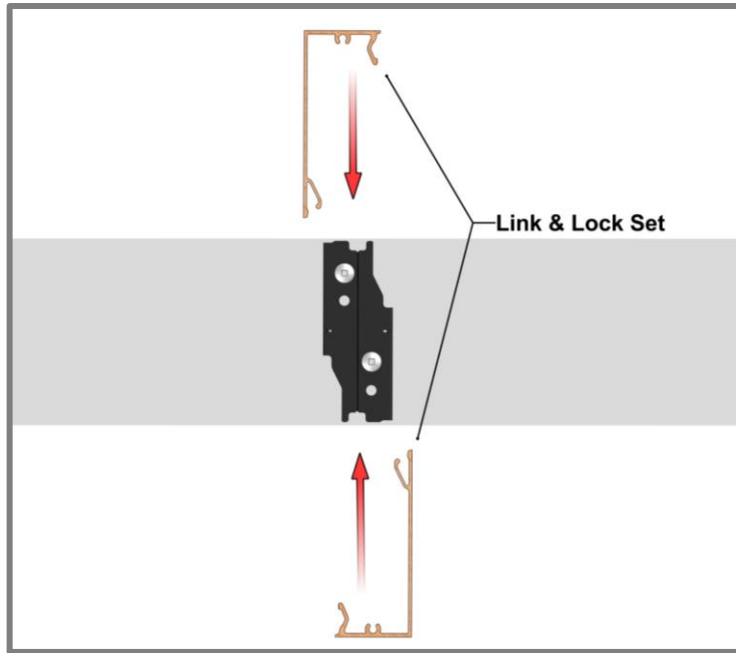

Large spans with Internal Stiffener

Requirements for large spans:

- Two Mounting Clips with #12 fasteners min, (#14 for L&L HD) are used at both ends with a minimum distance apart of 5" O.C.
- An Internal Stiffener is added to reinforce the Link & Lock set for spans up to 12' max @30psf.
- Stiffener must be one continuous member from attachment to attachment.
- Double-sided Tape is used to place the Stiffener onto the Link & Lock. The tape is placed on the center of the Stiffener and then pressed onto far end of the back "L" as shown on the next page.



See **Appendix for allowable spans for project specific wind load.**
Allowable Span - Tables 3-6

Step 1

Place predrilled Link & Lock back "L" into position (See Drilling page). It is good practice to check your installation every 2-3 rows for level/plumb and flat/straight, for best results.

Step 2

Install back "L" using #12 Fasteners min, (#14 for L&L HD) and Mounting Clips at end attachment points with a minimum distance apart of 5" O.C.

Note: Be sure to fasten in the center of the 1/2" holes to allow for movement each way. Hard fasten one end of each length to prevent migration of the material over time.

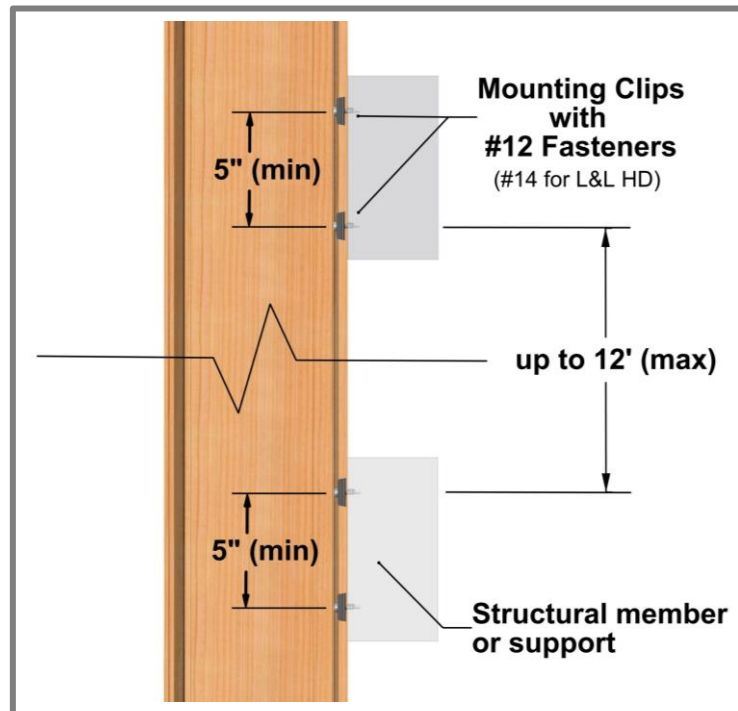

Step 3

Peel and place the Double-sided tape onto the back of the Stiffener O.C. Peel the second side and install the Stiffener as shown in the image pressing down to adhere to the tape.

Note: Install Stiffener 1" (min) from the end of the L&L to allow space for the End Cap as seen below.

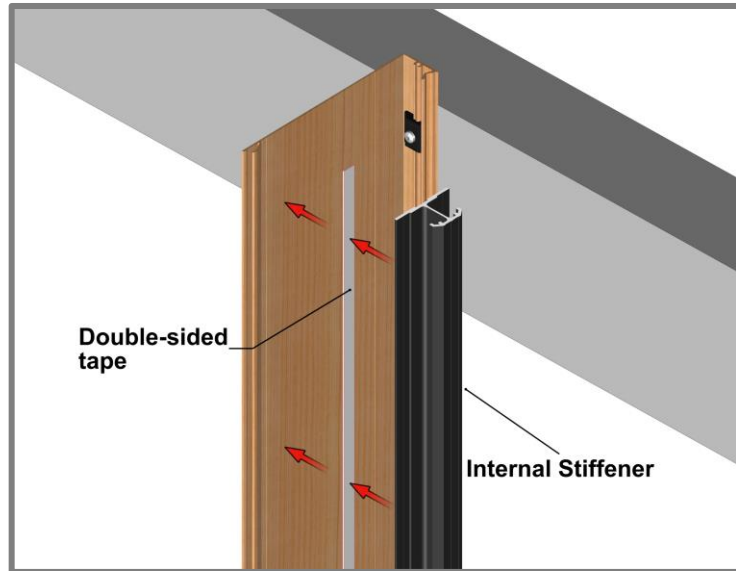

Make sure the Stiffener is located at the end of the back "L" and the tape is in the center of the stiffener.

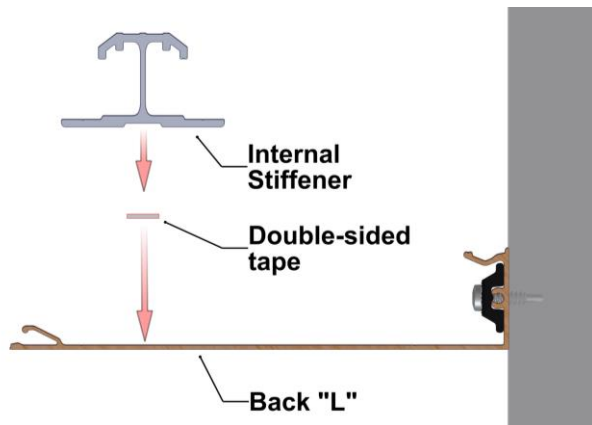

Step 4

-Fastening Stiffener in Fin orientation

Mechanically fasten the Stiffener to the back "L" using 1/8" Dome Head Rivets (Aluminum). Drill the flange of the Stiffener using a 1/8" Drill bit and fasten two Rivets at the top or one end to mitigate movement of the stiffener over time.

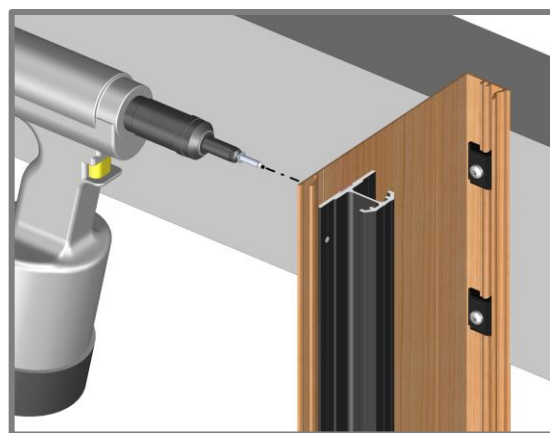

Step 4.1

-Fastening Stiffener Batten orientation
Mechanically fasten the Stiffener to the back "L" using the Mounting Clips and #12 Fasteners.

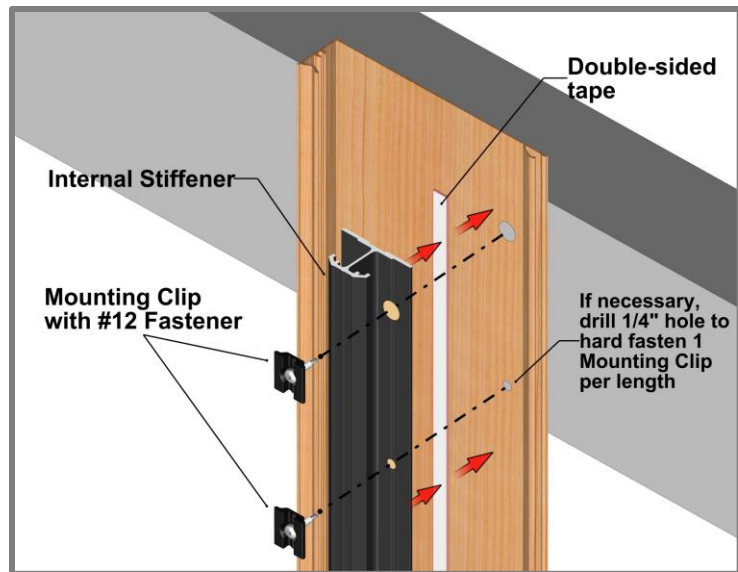

Step 5

Refer to Front "L" and End Cap install steps and details.
Install Stiffener with space at the end for the End Cap to be installed.



Link & Lock HD

- Used for greater spans compared to standard Link & Lock
- Available sizes: 4", 6" & 8" (2" depth)
- Uses standard Mounting Clip, Isolation Washer and attachment methods
- Use #14 Fasteners

Refer to System Layout and Install steps section for typical install details.

To Compare allowable spans:
See **Appendix for allowable spans for project specific wind load.**
Allowable Span – Tables 4-6

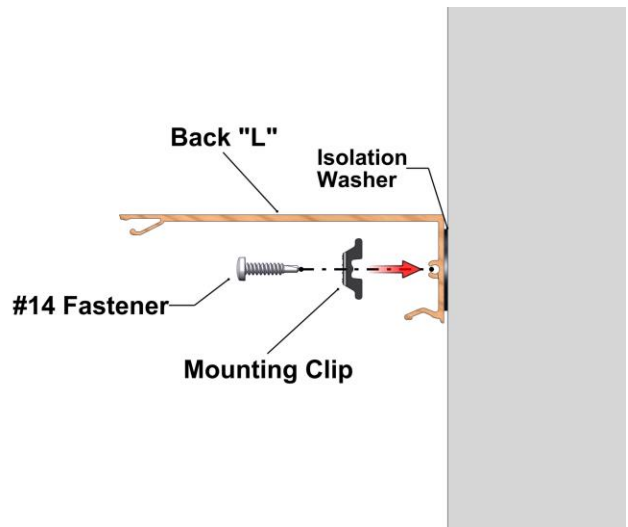

6" L&L
6' span max
@30PSF

6" L&L HD
12' span max
@30PSF

Profile Comparison

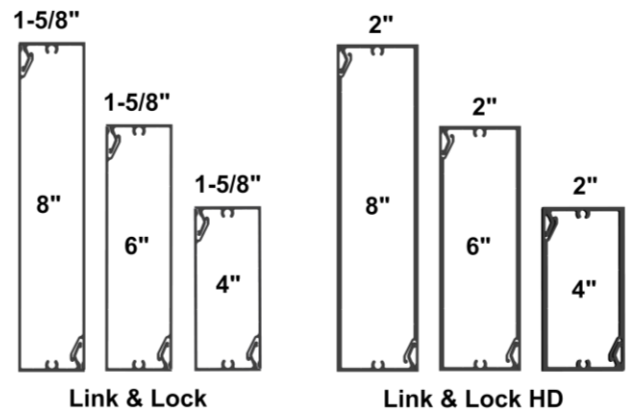

4x4 & 4x6 Link & Lock

- Available sizes: 4"x4" & 4"x6"
- Uses standard Mounting Clip and attachment methods with #12 Fasteners

Refer to System Layout and Install steps section for typical install details.

See **Appendix for allowable spans for project specific wind load.**
Allowable Span – Tables 7 & 8.

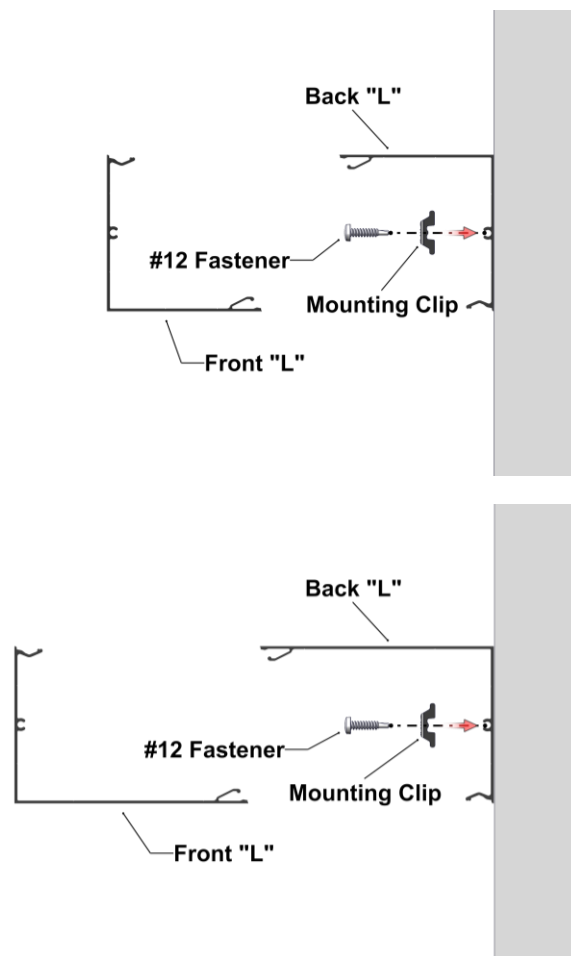

Link & Lock Brackets

- Alternate option for securing L&L cladding
- Attachment from L&L to bracket: use 1/4" Socket Head Screws, washers, locknuts & Mounting Clips included in order
- Attachment to structural element: Min #12 Fasteners (Min head diameter of 11mm) by others
- For expansion & contraction hard fasten only one fixed bracket per L&L run.
- Sliding Brackets are used for floor/slab deflection.

Note: Use lubricant for all bracket attachments. See following pages for details.

See **Appendix for L&L Bracket Max. Spacing. Table 9.**

Link & Lock Bracket Options

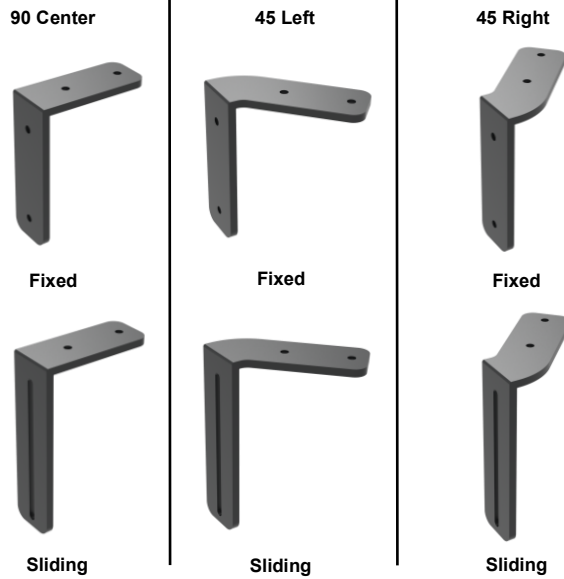

Single Bracket for horizontal substrate

Fixed Bracket (Hard fastened with 1/4" holes)

Fixed Bracket (Expansion 1/2" holes)

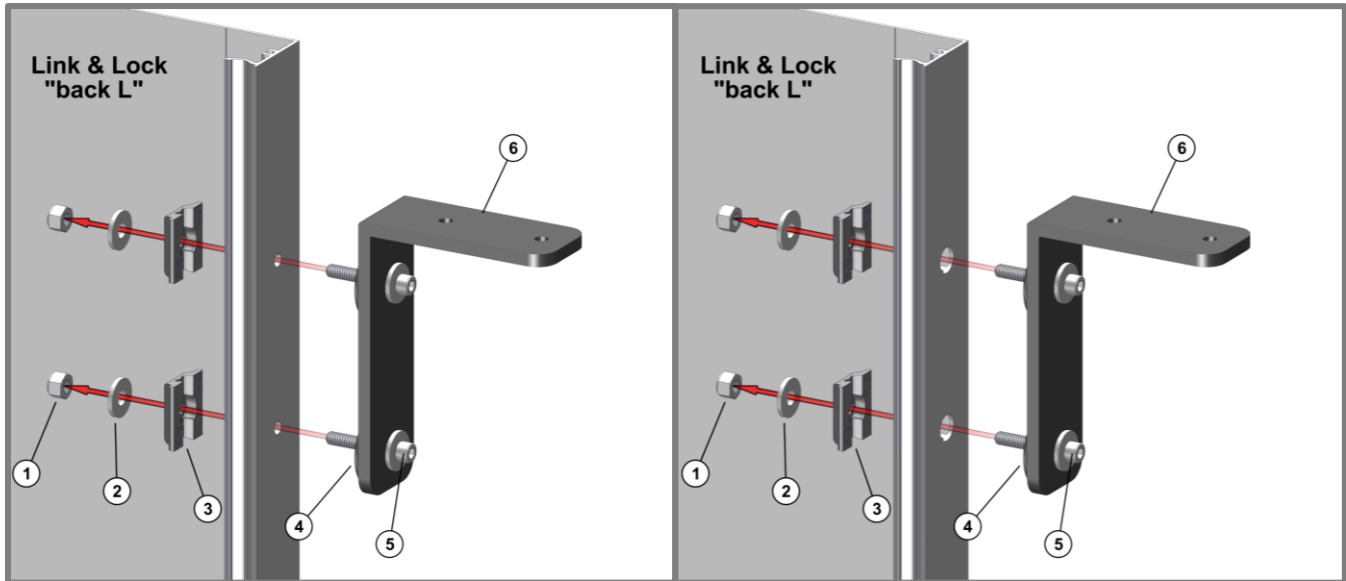

No.	Description	Material	Qty
1	1/4" -20 Locknut	Stainless Steel Nylon-Insert	2
2	Washer, 1/4" screw size, 0.75" OD	Stainless Steel	4
3	Link & Lock Mounting Clip	Nylon w. Stainless Washer	2
4	Isolation Washer for 1/4" size	Nylon, Black	2
5	1/4" -20 Socket Head Screw, 1-1/2" length	Stainless Steel	2
6	Link & Lock Bracket -90 Center Fixed	6005A Aluminum	1

Sliding Bracket (Use 1/4" holes)

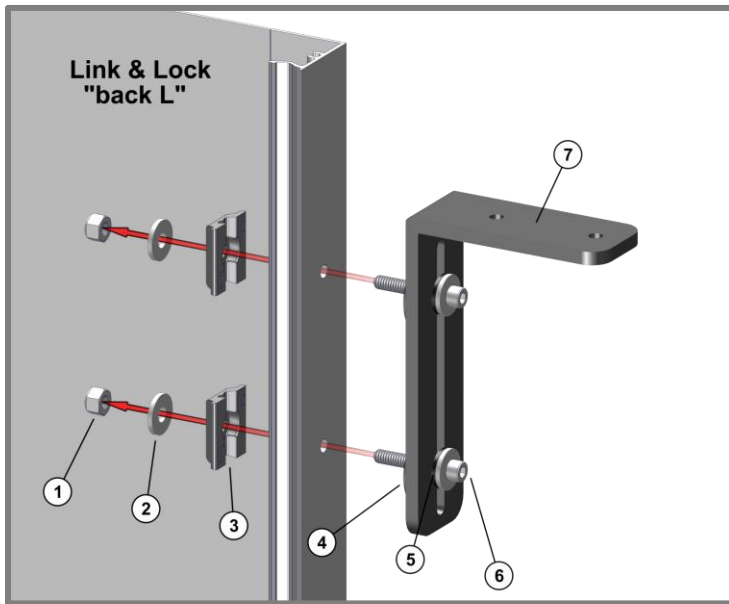

Note: Use Sliding Bracket only when attachment conditions require large movement. (Ex. Slab deflection in parking garages).

No.	Description	Material	Qty
1	1/4" -20 Locknut	Stainless Steel Nylon-Insert	2
2	Washer, 1/4" screw size, 0.75" OD	Stainless Steel	4
3	Link & Lock Mounting Clip	Nylon w. Stainless Washer	2
4	Isolation Washer for 1/4" screw size	Nylon, Black	2
5	Plastic Washer, 1/4" screw size, 0.734 OD	Nylon, Black	2
6	1/4" -20 Socket Head Screw, 1-1/2" length	Stainless Steel	2
7	Link & Lock Bracket -90 Center Sliding	6005A Aluminum	1

Dual Bracket for vertical substrate

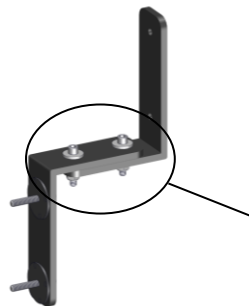
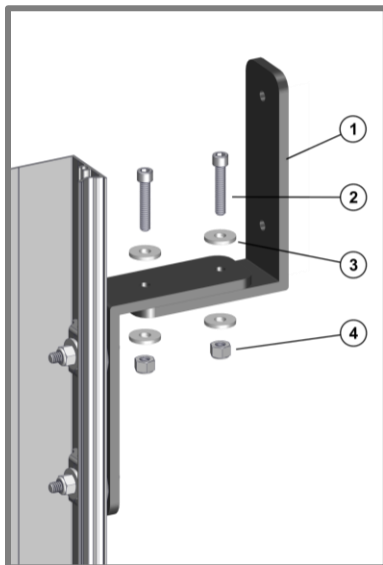

Dual Bracket components are loosely pre-assembled by manufacturer. Adjust as required. Once in place add lubricant and tighten to the manufacturer's specifications. See following pages for lubricant details.

No.	Description	Material	Qty
1	Link & Lock Dual Bracket -90 Center Fixed	6005A Aluminum	1
2	1/4" -20 Socket Head Screw, 1-1/4" length	Stainless Steel	2
3	Washer, 1/4" screw size, 0.75" OD	Stainless Steel	4
4	1/4" -20 Locknut	Stainless Steel Nylon-Insert	2

Install steps

Step 1

Layout & install Link & Lock Brackets. It is good practice to check for level/plumb and flat/straight, for best results.

! TIP: Install one run of L&L Brackets with the L&L to confirm measurements.

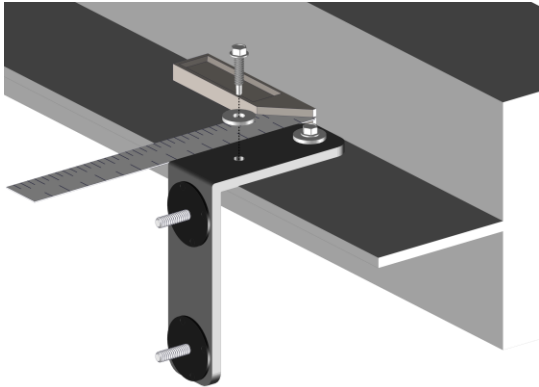

#12 Fasteners with washers by others (Min head diameter of 11mm)

X

X – see allowable span Table 9

1 9/16"
-for Sliding Bracket unloaded. For loaded condition check with your local engineer.

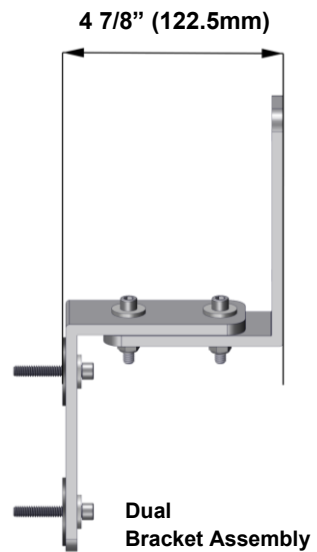
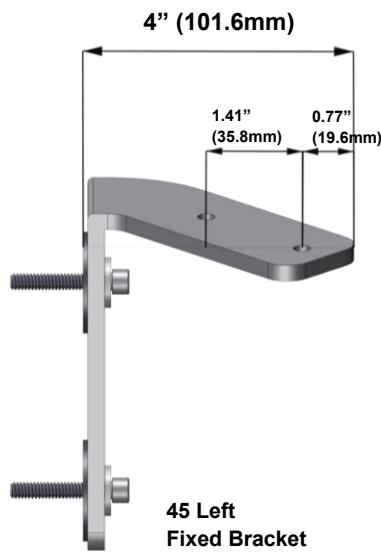
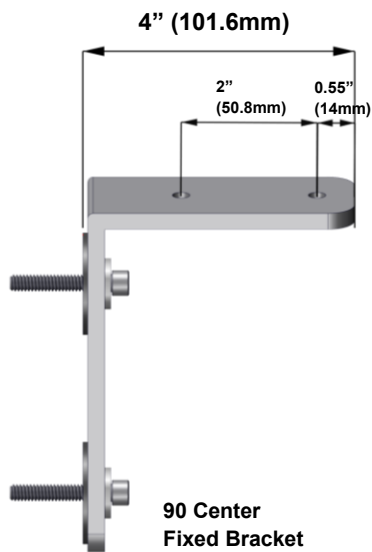

Step 2

Drill out back "L" of the Link & Lock.
For dimensions review drawing details provided by Longboard if required.

- **1/4" holes**
-for hard fastening one Bracket per run
-for Sliding Brackets if used
- **1/2" holes** for expansion & contraction on the rest of the Fixed Brackets

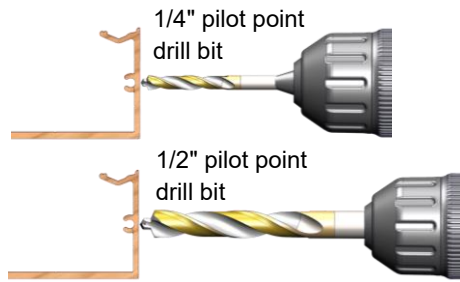

Step 3

Add 1/8" drop of lubricant to bolt threads before installing locknut.

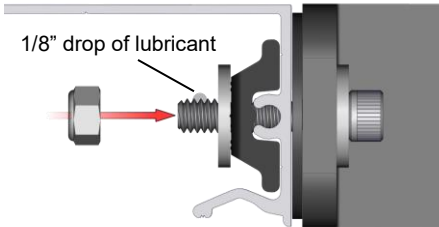

For L&L Bracket fastening, use Permatex Anti-Seize 77134.

Step 4

Install back "L" onto brackets.

	Nut driver	Allen key
Fixed & Sliding Brackets	7/16"	3/16"

-For recommended torque value see Table 9 notes.

Step 4.1 Install Internal Stiffener if required. See stiffener install steps for details.

Step 5

Install front "L" onto back "L" and End Caps. See L&L install steps for details.

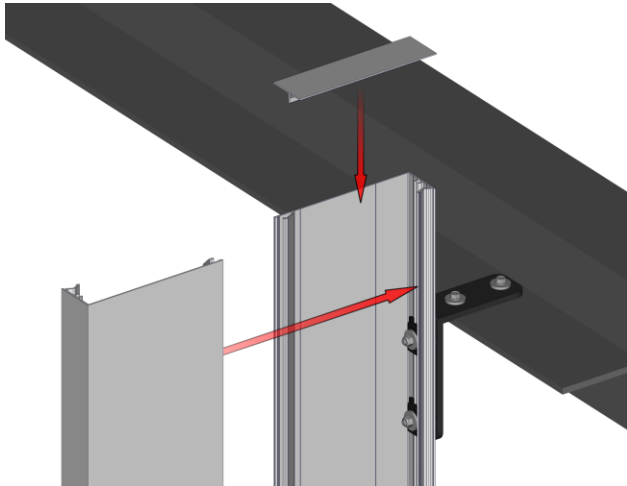

Orientation options

Fixed options shown, sliding options are available for slab deflection or building settlement.



Left

Center

Right



Center Horizontal Batten

Center Vertical Batten

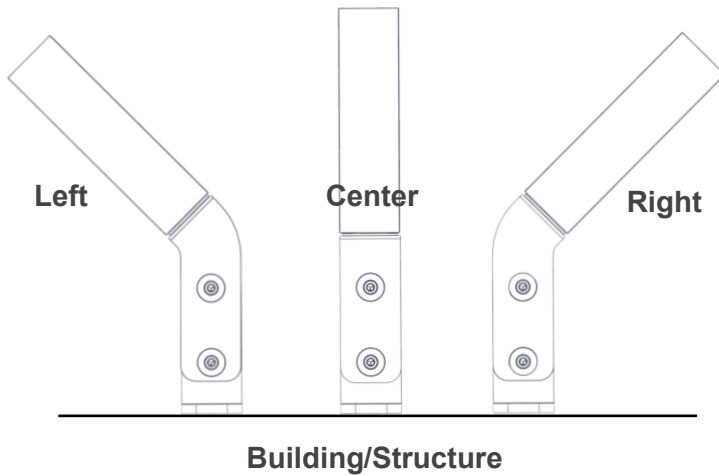

Left

Center

Right

Building/Structure



Appendix

Expansion and Contraction Tables

TABLE 1 - IMPERIAL

		AVERAGE TEMPERATURE AT TIME OF CUTTING & INSTALLATION											
°C		-50	-40	-30	-20	-10	0	10	20	30	40	50	
°F		-58	-40	-22	-4	14	32	50	68	86	104	122	
MIN/MAX POST CONSTRUCTION TEMP.	°C	°F	EXPANSION OR CONTRACTION (INCH/FOOT)										
	-50	-58	0.000	-0.003	-0.005	-0.008	-0.011	-0.014	-0.016	-0.019	-0.022	-0.024	-0.027
	-40	-40	0.003	0.000	-0.003	-0.005	-0.008	-0.011	-0.014	-0.016	-0.019	-0.022	-0.024
	-30	-22	0.005	0.003	0.000	-0.003	-0.005	-0.008	-0.011	-0.014	-0.016	-0.019	-0.022
	-20	-4	0.008	0.005	0.003	0.000	-0.003	-0.005	-0.008	-0.011	-0.014	-0.016	-0.019
	-10	14	0.011	0.008	0.005	0.003	0.000	-0.003	-0.005	-0.008	-0.011	-0.014	-0.016
	0	32	0.014	0.011	0.008	0.005	0.003	0.000	-0.003	-0.005	-0.008	-0.011	-0.014
	10	50	0.016	0.014	0.011	0.008	0.005	0.003	0.000	-0.003	-0.005	-0.008	-0.011
	20	68	0.019	0.016	0.014	0.011	0.008	0.005	0.003	0.000	-0.003	-0.005	-0.008
	30	86	0.022	0.019	0.016	0.014	0.011	0.008	0.005	0.003	0.000	-0.003	-0.005
	40	104	0.024	0.022	0.019	0.016	0.014	0.011	0.008	0.005	0.003	0.000	-0.003
	50	122	0.027	0.024	0.022	0.019	0.016	0.014	0.011	0.008	0.005	0.003	0.000

TABLE 2 - METRIC

		AVERAGE TEMPERATURE AT TIME OF CUTTING & INSTALLATION											
°C		-50	-40	-30	-20	-10	0	10	20	30	40	50	
°F		-58	-40	-22	-4	14	32	50	68	86	104	122	
MIN/MAX POST CONSTRUCTION TEMP.	°C	°F	EXPANSION OR CONTRACTION (MM/METER)										
	-50	-58	0.000	-0.230	-0.460	-0.690	-0.920	-1.150	-1.380	-1.610	-1.840	-2.070	-2.300
	-40	-40	0.230	0.000	-0.230	-0.460	-0.690	-0.920	-1.150	-1.380	-1.610	-1.840	-2.070
	-30	-22	0.460	0.230	0.000	-0.230	-0.460	-0.690	-0.920	-1.150	-1.380	-1.610	-1.840
	-20	-4	0.690	0.460	0.230	0.000	-0.230	-0.460	-0.690	-0.920	-1.150	-1.380	-1.610
	-10	14	0.920	0.690	0.460	0.230	0.000	-0.230	-0.460	-0.690	-0.920	-1.150	-1.380
	0	32	1.150	0.920	0.690	0.460	0.230	0.000	-0.230	-0.460	-0.690	-0.920	-1.150
	10	50	1.380	1.150	0.920	0.690	0.460	0.230	0.000	-0.230	-0.460	-0.690	-0.920
	20	68	1.610	1.380	1.150	0.920	0.690	0.460	0.230	0.000	-0.230	-0.460	-0.690
	30	86	1.840	1.610	1.380	1.150	0.920	0.690	0.460	0.230	0.000	-0.230	-0.460
	40	104	2.070	1.840	1.610	1.380	1.150	0.920	0.690	0.460	0.230	0.000	-0.230
	50	122	2.300	2.070	1.840	1.610	1.380	1.150	0.920	0.690	0.460	0.230	0.000

TABLE 3

		FASTENER SPACING - LOAD TABLE										v1.1
		PSF (Factored / Ultimate)										
2" LINK & LOCK™		20	30	40	50	60	70	80	90	100	110	120
Standard												
ALLOWABLE SPAN (FT)*	4'											
	6'											
	8'											
	10'											
*CANTILEVERS are not to exceed half (1/2) the allowable span to a maximum of 3'												
<i>Calculations are using L/180 deflection limits</i>												
SUBSTRATE TYPE	SUBSTRATE REQUIREMENTS		ANCHOR DESCRIPTION		MIN. EMBEDMENT		MIN. EDGE DISTANCE					
WOOD	Min. specific gravity = 0.55 wood		#12 Pan Head Wood Screw		1-1/2"		1"					
STEEL	Min. 18 ga., Min. Fy=33 ksi.		#12 Self-Drilling or Self-Tapping Screw (Grade 5)		3 threads penetration past metal structure		1/2"					
ALUMINUM	Min. 1/8", Min. 8063-T5		3/16" ITW Tapcon		1-1/2"		1-3/4"					
CONCRETE	Min. 3000 psi				1"		2"					
HOLLOWGROUT-FILLED CMU	Conforms to ASTM C-90, with Min. compressive strength of 2000 psi											

GENERAL NOTES:

- This product has been designed and manufactured to comply with the current Florida Building Code (FBC), **INCLUDING** HVHZ and has been evaluated according to the following:
 - Section 1709.8
 - ASTM E8-16
- Adequacy of the structural concrete/masonry and 2X framing as a main wind force resisting system capable of withstanding and transferring applied product loads to the foundation is the responsibility of the engineer or architect of record for the project of installation.
- Substrate shall be designed and anchored to properly transfer all loads to the structure. Buck design and installation is the responsibility of the engineer or architect of record for the project of installation.
- The installation details described herein are generic and may not reflect actual conditions for a specific site. If site conditions cause installation to deviate from the requirements detailed herein, a licensed engineer or architect shall prepare site specific documents for use with this document.
- Link & Lock is not designed to be a life-safety item. Designs of this nature are the responsibility of the engineer or architect of record.

INSTALLATION NOTES:

- One (1) installation anchor is required at each location. Minimum of two (2) anchors per batten.
- Spacing is from fastener center to center.
- The number of installation anchors per the table is the minimum number of anchors to be used for product installation.
- Install individual installation anchors within a tolerance of +/- 1/2" of the specified spacings. Tolerances are not cumulative from one installation anchor to the next.
- Minimum embedment and edge distance exclude wall finishes, including but not limited to stucco, foam, brick veneer, sheathing and siding.
- Installation anchors and associated hardware must be made of corrosion resistant material or have a corrosion resistant coating. Common fastener types can be equal or better to a & b listed below.
 - a. Zinc plated fasteners for moderate climate zones
 - b. 316 Stainless Steel fasteners for coastal climate zones
- For hollow block and grout filled CMU block, do not install installation anchors into mortar joints. Edge distance is measured from free edge of block or edge of mortar joint into face shell of block.
- Installation anchors shall be installed in accordance with anchor manufacturer's installation instructions, and anchors shall not be used in substrates with strengths less than the minimum strength specified by the anchor manufacturer.
- When using end mounts, span distance is measured center to center of each end mount.

TABLE 4

4" LINK & LOCK™			FASTENER SPACING - LOAD TABLE										
			PSF (Factored / Ultimate)										
Standard	Standard w. Stiffener	HD	20	30	40	50	60	70	80	90	100	110	120
ALLOWABLE SPAN (FT)*	2'												
	4'								Standard w. Stiffener				
	6'							Standard w. Stiffener		HD			
	8'				Standard w. Stiffener			HD					
	10'	Standard w. Stiffener			HD								
	12'	Standard w. Stiffener	HD										

*CANTILEVERS are not to exceed half (1/2) the allowable span to a maximum of 3'

Calculations are using L/180 deflection limits

SUBSTRATE TYPE	SUBSTRATE REQUIREMENTS	ANCHOR DESCRIPTION	MIN. EMBEDMENT	MIN. EDGE DISTANCE
WOOD	Min. specific gravity = 0.55 wood	#12 Pan Head Wood Screw	1-1/2"	1"
STEEL	Min. 18 ga., Min. Fy=33 ksi.	#12 Self-Drilling or Self-Tapping Screw (Grade 5)	3 threads penetration past metal structure	1/2"
ALUMINUM	Min. 1/8", Min. 6063-T5			
CONCRETE	Min. 3000 psi	3/16" ITW Tapcon	1-1/2"	1-3/4"
HOLLOW/GROUT-FILLED CMU	Conforms to ASTM C-90, with Min. compressive strength of 2000 psi		1"	2"

GENERAL NOTES:

- This product has been designed and manufactured to comply with the current Florida Building Code (FBC), **INCLUDING** HVHZ and has been evaluated according to the following:
 - Section 1709.8
 - ASTM E8-16
- Adequacy of the structural concrete/masonry and 2X framing as a main wind force resisting system capable of withstanding and transferring applied product loads to the foundation is the responsibility of the engineer or architect of record for the project of installation.
- Substrate shall be designed and anchored to properly transfer all loads to the structure. Buck design and installation is the responsibility of the engineer or architect of record for the project of installation.
- The installation details described herein are generic and may not reflect actual conditions for a specific site. If site conditions cause installation to deviate from the requirements detailed herein, a licensed engineer or architect shall prepare site specific documents for use with this document.
- Link & Lock is not designed to be a life-safety item. Designs of this nature are the responsibility of the engineer or architect of record.

INSTALLATION NOTES:

- One (1) installation anchor is required at each location. Minimum of two (2) anchors per batten.
- Spacing is from fastener center to center.
- The number of installation anchors per the table is the minimum number of anchors to be used for product installation.
- Install individual installation anchors within a tolerance of +/- 1/2" of the specified spacings. Tolerances are not cumulative from one installation anchor to the next.
- Minimum embedment and edge distance exclude wall finishes, including but not limited to stucco, foam, brick veneer, sheathing and siding.
- Installation anchors and associated hardware must be made of corrosion resistant material or have a corrosion resistant coating. Common fastener types can be equal or better to a & b listed below:
 - Zinc plated fasteners for moderate climate zones
 - 316 Stainless Steel fasteners for coastal climate zones
- For hollow block and grout filled CMU block, do not install installation anchors into mortar joints. Edge distance is measured from free edge of block or edge of mortar joint into face shell of block.
- Installation anchors shall be installed in accordance with anchor manufacturer's installation instructions, and anchors shall not be used in substrates with strengths less than the minimum strength specified by the anchor manufacturer.
- When using end mounts, span distance is measured center to center of each end mount.

TABLE 5



FASTENER SPACING - LOAD TABLE

v1.1

6" LINK & LOCK™			PSF (Factored / Ultimate)										
			20	30	40	50	60	70	80	90	100	110	120
Standard	Standard w. Stiffener	HD											
ALLOWABLE SPAN (FT)*	2'												
	4'												Standard w. Stiffener
	6'				Standard w. Stiffener	HD							
	8'	Standard w. Stiffener		HD									
	10'	Standard w. Stiffener		HD									
	12'	HD											

*CANTILEVERS are not to exceed half (1/2) the allowable span to a maximum of 3'

Calculations are using L/180 deflection limits

SUBSTRATE TYPE	SUBSTRATE REQUIREMENTS	ANCHOR DESCRIPTION	MIN. EMBEDMENT	MIN. EDGE DISTANCE
WOOD	Min. specific gravity = 0.55 wood	#12 Pan Head Wood Screw	1-1/2"	1"
STEEL	Min. 18 ga., Min. Fy=33 ksi.	#12 Self-Drilling or Self-Tapping Screw (Grade 5)	3 threads penetration past metal structure	1/2"
ALUMINUM	Min. 1/8", Min. 6063-T5			
CONCRETE	Min. 3000 psi	3/16" ITW Tapcon	1-1/2"	1-3/4"
HOLLOW/GROUT-FILLED CMU	Conforms to ASTM C-90, with Min. compressive strength of 2000 psi		1"	2"

GENERAL NOTES:

- This product has been designed and manufactured to comply with the current Florida Building Code (FBC), **INCLUDING** HVHZ and has been evaluated according to the following:
 - Section 1709.8
 - ASTM E8-16
- Adequacy of the structural concrete/masonry and 2X framing as a main wind force resisting system, capable of withstanding and transferring applied product loads to the foundation is the responsibility of the engineer or architect of record for the project of installation.
- Substrate shall be designed and anchored to properly transfer all loads to the structure. Buck design and installation is the responsibility of the engineer or architect of record for the project of installation.
- The installation details described herein are generic and may not reflect actual conditions for a specific site. If site conditions cause installation to deviate from the requirements detailed herein, a licensed engineer or architect shall prepare site specific documents for use with this document.
- Link & Lock is not designed to be a life-safety item. Designs of this nature are the responsibility of the engineer or architect of record.

INSTALLATION NOTES:

- One (1) installation anchor is required at each location. Minimum of two (2) anchors per batten.
- Spacing is from fastener center to center.
- The number of installation anchors per the table is the minimum number of anchors to be used for product installation.
- Install individual installation anchors within a tolerance of +/- 1/2" of the specified spacings. Tolerances are not cumulative from one installation anchor to the next.
- Minimum embedment and edge distance exclude wall finishes, including but not limited to stucco, foam, brick veneer, sheathing and siding.
- Installation anchors and associated hardware must be made of corrosion resistant material or have a corrosion resistant coating. Common fastener types can be equal or better to a & b listed below:
 - Zinc plated fasteners for moderate climate zones
 - 316 Stainless Steel fasteners for coastal climate zones
- For hollow block and grout filled CMU block, do not install installation anchors into mortar joints. Edge distance is measured from free edge of block or edge of mortar joint into face shell of block.
- Installation anchors shall be installed in accordance with anchor manufacturer's installation instructions, and anchors shall not be used in substrates with strengths less than the minimum strength specified by the anchor manufacturer.
- When using end mounts, span distance is measured center to center of each end mount.

TABLE 6

8" LINK & LOCK™			PSF (Factored / Ultimate)										
Standard	Standard w. Stiffener	HD	20	30	40	50	60	70	80	90	100	110	120
ALLOWABLE SPAN (FT)*			2'										
			4'					Standard w. Stiffener					HD
			6'			Standard w. Stiffener	HD						
			8'	Standard w. Stiffener	HD								
			10'	HD									

*CANTILEVERS are not to exceed half (1/2) the allowable span to a maximum of 3'

Calculations are using L/180 deflection limits

SUBSTRATE TYPE	SUBSTRATE REQUIREMENTS	ANCHOR DESCRIPTION	MIN. EMBEDMENT	MIN. EDGE DISTANCE
WOOD	Min. specific gravity = 0.55 wood	#12 Pan Head Wood Screw	1-1/2"	1"
STEEL	Min. 18 ga., Min. Fy=33 ksi.	#12 Self-Drilling or Self-Tapping Screw (Grade 5)	3 threads penetration past metal structure	1/2"
ALUMINUM	Min. 1/8", Min. 6063-T5			
CONCRETE	Min. 3000 psi	3/16" ITW Tapcon	1-1/2"	1-3/4"
HOLLOW/GROUT-FILLED CMU	Conforms to ASTM C-90, with Min. compressive strength of 2000 psi		1"	2"

GENERAL NOTES:

- This product has been designed and manufactured to comply with the current Florida Building Code (FBC), **INCLUDING** HVHZ and has been evaluated according to the following:
 - Section 1709.8
 - ASTM E8-16
- Adequacy of the structural concrete/masonry and 2X framing as a main wind force resisting system capable of withstanding and transferring applied product loads to the foundation is the responsibility of the engineer or architect of record for the project of installation.
- Substrate shall be designed and anchored to properly transfer all loads to the structure. Buck design and installation is the responsibility of the engineer or architect of record for the project of installation.
- The installation details described herein are generic and may not reflect actual conditions for a specific site. If site conditions cause installation to deviate from the requirements detailed herein, a licensed engineer or architect shall prepare site specific documents for use with this document.
- Link & Lock is not designed to be a life-safety item. Designs of this nature are the responsibility of the engineer or architect of record.

INSTALLATION NOTES:

- One (1) installation anchor is required at each location. Minimum of two (2) anchors per batten.
- Spacing is from fastener center to center.
- The number of installation anchors per the table is the minimum number of anchors to be used for product installation.
- Install individual installation anchors within a tolerance of +/- 1/2" of the specified spacings. Tolerances are not cumulative from one installation anchor to the next.
- Minimum embedment and edge distance exclude wall finishes, including but not limited to stucco, foam, brick veneer, sheathing and siding.
- Installation anchors and associated hardware must be made of corrosion resistant material or have a corrosion resistant coating. Common fastener types can be equal or better to a & b listed below:
 - Zinc plated fasteners for moderate climate zones
 - 316 Stainless Steel fasteners for coastal climate zones
- For hollow block and grout filled CMU block, do not install installation anchors into mortar joints. Edge distance is measured from free edge of block or edge of mortar joint into face shell of block.
- Installation anchors shall be installed in accordance with anchor manufacturer's installation instructions, and anchors shall not be used in substrates with strengths less than the minimum strength specified by the anchor manufacturer.
- When using end mounts, span distance is measured center to center of each end mount.

TABLE 7



FASTENER SPACING - LOAD TABLE

v.1.2

4X4 LINK & LOCK™		PSF (Factored / Ultimate)										
		20	30	40	50	60	70	80	90	100	110	120
Standard												
ALLOWABLE SPAN (FT)*	8'											
	10'											
	12'											

*CANTILEVERS are not to exceed 3'

Calculations are using L/180 deflection limits

SUBSTRATE TYPE	SUBSTRATE REQUIREMENTS	ANCHOR DESCRIPTION	MIN. EMBEDMENT	MIN. EDGE DISTANCE
WOOD	Min. specific gravity = 0.55 wood	#12 Pan Head or Flanged Hex Head Wood Screw	1-1/2"	1"
STEEL	Min. 18 ga., Min. Fy=36 ksi.	#12 Self-Drilling or Self-Tapping Screw Pan Head or Flanged Hex Head Wood Screw (Grade 5)	3 threads penetration past metal structure	1/2"
ALUMINUM	Min. 1/8", Min. 6063-T5			
CONCRETE	Min. 3000 psi	3/16" ITW Tapcon	1-1/2"	1-3/4"
HOLLOW/GROUT-FILLED CMU	Conforms to ASTM C-90, with Min. compressive strength of 2000 psi		1"	2"

GENERAL NOTES:

- Adequacy of the structural concrete/masonry and 2X framing as a main wind force resisting system capable of withstanding and transferring applied product loads to the foundation is the responsibility of the engineer or architect of record for the project of installation.
- Substrate shall be designed and anchored to properly transfer all loads to the structure. Buck design and installation is the responsibility of the engineer or architect of record for the project of installation.
- The installation details described herein are generic and may not reflect actual conditions for a specific site. If site conditions cause installation to deviate from the requirements detailed herein, a licensed engineer or architect shall prepare site specific documents for use with this document.
- Link & Lock is not designed to be a life-safety item. Designs of this nature are the responsibility of the engineer or architect of record.

INSTALLATION NOTES:

- One (1) installation anchor is required at each location. Minimum of two (2) anchors per batten.
- Spacing is from fastener center to center.
- The number of installation anchors per the table is the minimum number of anchors to be used for product installation.
- Install individual installation anchors within a tolerance of +/- 1/2" of the specified spacings. Tolerances are not cumulative from one installation anchor to the next.
- Minimum embedment and edge distance exclude wall finishes, including but not limited to stucco, foam, brick veneer, sheathing and siding.
- Installation anchors and associated hardware must be made of corrosion resistant material or have a corrosion resistant coating. Common fastener types can be equal or better to a & b listed below:
 - Zinc plated fasteners for moderate climate zones
 - 316 Stainless Steel fasteners for coastal climate zones
- For hollow block and grout filled CMU block, do not install installation anchors into mortar joints. Edge distance is measured from free edge of block or edge of mortar joint into face shell of block.
- Installation anchors shall be installed in accordance with anchor manufacturer's installation instructions, and anchors shall not be used in substrates with strengths less than the minimum strength specified by the anchor manufacturer.

TABLE 8

LONGBOARD[®] INSPIRING ARCHITECTURE		FASTENER SPACING - LOAD TABLE										
		PSF (Factored / Ultimate)										
4X6 LINK & LOCK™		20	30	40	50	60	70	80	90	100	110	120
Standard												
ALLOWABLE SPAN (FT)*	8'											
	10'											
	12'											
*CANTILEVERS are not to exceed 3'												
<i>Calculations are using L/180 deflection limits</i>												
SUBSTRATE TYPE	SUBSTRATE REQUIREMENTS	ANCHOR DESCRIPTION					MIN. EMBEDMENT		MIN. EDGE DISTANCE			
WOOD	Min. specific gravity = 0.55 wood	#12 Pan Head or Flanged Hex Head Wood Screw					1-1/2"		1"			
STEEL	Min. 18 ga., Min. Fy=36 ksi.	#12 Self-Drilling or Self-Tapping Screw Pan Head or Flanged Hex Head Wood Screw (Grade 5)					3 threads penetration past metal structure		1/2"			
ALUMINUM	Min. 1/8", Min. 6063-T5											
CONCRETE	Min. 3000 psi						1-1/2"		1-3/4"			
HOLLOW/GROUT-FILLED CMU	Conforms to ASTM C-90, with Min. compressive strength of 2000 psi	3/16" ITW Tapcon					1"		2"			

GENERAL NOTES:

- Adequacy of the structural concrete/masonry and 2X framing as a main wind force resisting system capable of withstanding and transferring applied product loads to the foundation is the responsibility of the engineer or architect of record for the project of installation.
- Substrate shall be designed and anchored to properly transfer all loads to the structure. Buck design and installation is the responsibility of the engineer or architect of record for the project of installation.
- The installation details described herein are generic and may not reflect actual conditions for a specific site. If site conditions cause installation to deviate from the requirements detailed herein, a licensed engineer or architect shall prepare site specific documents for use with this document.
- Link & Lock is not designed to be a life-safety item. Designs of this nature are the responsibility of the engineer or architect of record.

INSTALLATION NOTES:

- One (1) installation anchor is required at each location. Minimum of two (2) anchors per batten.
- Spacing is from fastener center to center.
- The number of installation anchors per the table is the minimum number of anchors to be used for product installation.
- Install individual installation anchors within a tolerance of +/- 1/2" of the specified spacings. Tolerances are not cumulative from one installation anchor to the next.
- Minimum embedment and edge distance exclude wall finishes, including but not limited to stucco, foam, brick veneer, sheathing and siding.
- Installation anchors and associated hardware must be made of corrosion resistant material or have a corrosion resistant coating. Common fastener types can be equal or better to a & b listed below:
 - Zinc plated fasteners for moderate climate zones
 - 316 Stainless Steel fasteners for coastal climate zones
- For hollow block and grout filled CMU block, do not install installation anchors into mortar joints. Edge distance is measured from free edge of block or edge of mortar joint into face shell of block.
- Installation anchors shall be installed in accordance with anchor manufacturer's installation instructions, and anchors shall not be used in substrates with strengths less than the minimum strength specified by the anchor manufacturer.

TABLE 9

LONGBOARD[®] INSPIRING ARCHITECTURE	LINK & LOCK™ BRACKET MAX. SPACING (FT)										
	WIND LOAD PSF (FACTORED/ULTIMATE)										
LINK & LOCK™ BATTEN	30	40	50	60	70	80	90	100	110	120	
1-5/8" x 2"	10'	8'			6'		4'			2'	
1-5/8" x 4"	8'	6'			4'					2'	
1-5/8" x 4" w. Internal Stiffener	12'	10'	8'		6'					4'	
1-5/8" x 6"	6'		4'				3'			2'	
1-5/8" x 6" w. Internal Stiffener	10'	8'	6'		4'				3'	2'	
1-5/8" x 8"	6'	4'					2'				
1-5/8" x 8" w. Internal Stiffener	8'	6'		4'			3'			2'	
2" x 4" HD	12'	10'	8'		6'					4'	
2" x 6" HD	10'	8'	6'		4'					3'	
2" x 8" HD	8'	6'	4'				3'			2'	

Recommended torque value for Link & Lock™ to Bracket attachment:

note 1 Factored Wind Load: max. 168 LBS/EA Bracket
 note 2 Factored Dead Load: max. 29 LBS/EA Fixed Bracket
 note 3 Fixed Bracket 1/4" -20 Socket Head Screw, 60-72 in/lbs + prevailing torque of self-locking nut
 note 4 Sliding Bracket 1/4" -20 Socket Head Screw, 48-60 in/lbs + prevailing torque of self-locking nut

April 25, 2024

Proper Handling of Longboard Products



To help avoid injury and product damage, Longboard products require proper handling to and from storage areas during installation. When carrying or installing any products it is recommended that they be moved or carried by at least two people with each support point approximately 4ft from the ends. **Carrying products without proper support can cause excessive bending which may damage the appearance or finish of the product.** Any short cut lengths should also be carried on edge while supporting the material. See below for details.

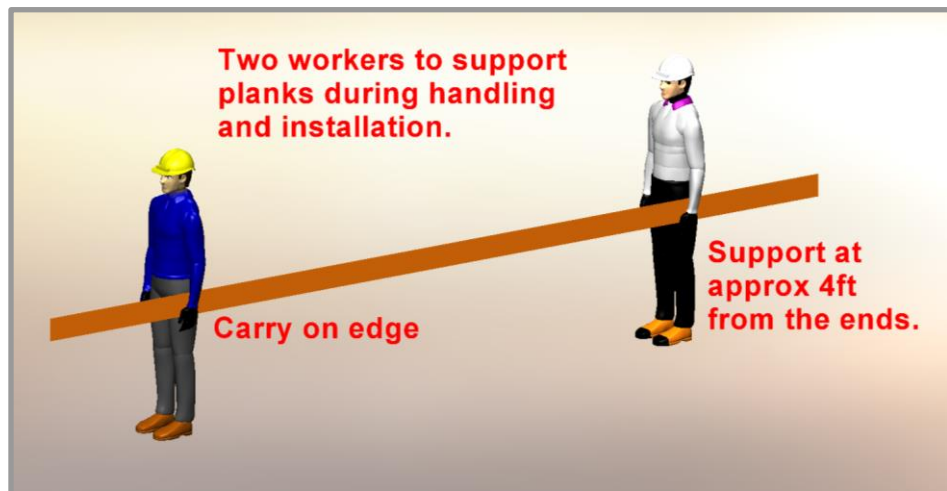
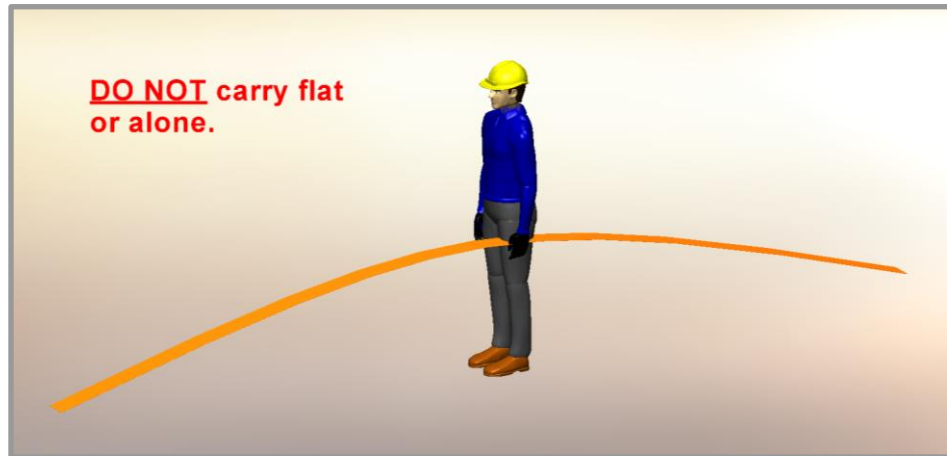

⚠️ Delivery, Storage & Handling ⚠️

- Always inspect the delivery for damage and contact LB ASAP if there are any issues: info@longboardproducts.com or 1-800-604-0343 and include your PO# and any pictures if possible. Longboard is not responsible for the installation of blemished or damaged material.
- Be sure to store the material flat, keep it dry, safe & secure and remain in unopened cartons until ready to be installed.
- Always wear appropriate PPE when handling products.

BLANK PAGE



Longboard Architectural Products Inc.
© Longboard Architectural Products Inc. All rights reserved.

Longboard® is a registered trademark of Longboard Architectural Products Inc.

Longboard
1777 Clearbrook Road
Abbotsford, BC V2T 8X8
Canada
longboardproducts.com

Every effort has been made to ensure that the information in these installation guidelines is accurate. Longboard is not responsible for printing or clerical errors.

For more information, contact client care at info@longboardproducts.com or call toll free 1-800-604-0343.