



LONGBOARD®
INSPIRING ARCHITECTURE

LINK & LOCK™ INFO SHEETS

INCLUDING

LINK & LOCK™ HD

LINK & LOCK™ BRACKETS

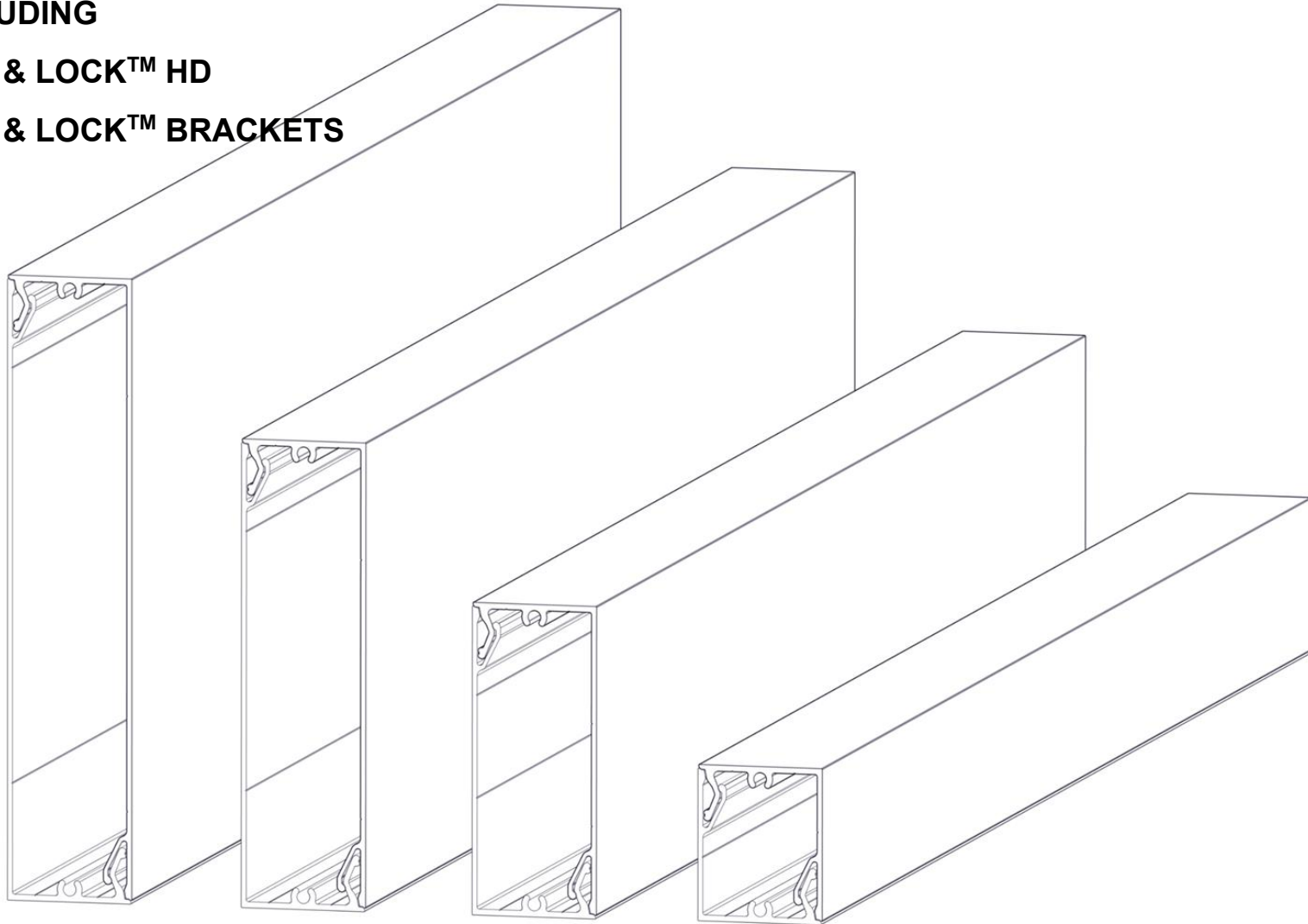

CRITICAL DETAILS



Note 1: We recommend calculating the site specific temperature ranges for thermal expansion & contraction values.

CUT TAPED/DRILLED ENDS

CUT Factory Ends.

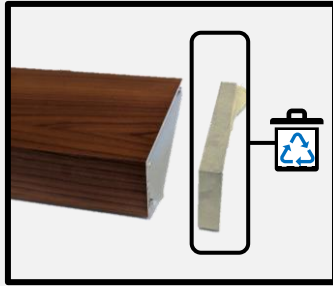

LAP JOINTS & THERMAL MOVEMENT¹

Overlap L&L joints min 2ft.



THERMAL CALCULATOR DOWNLOAD¹

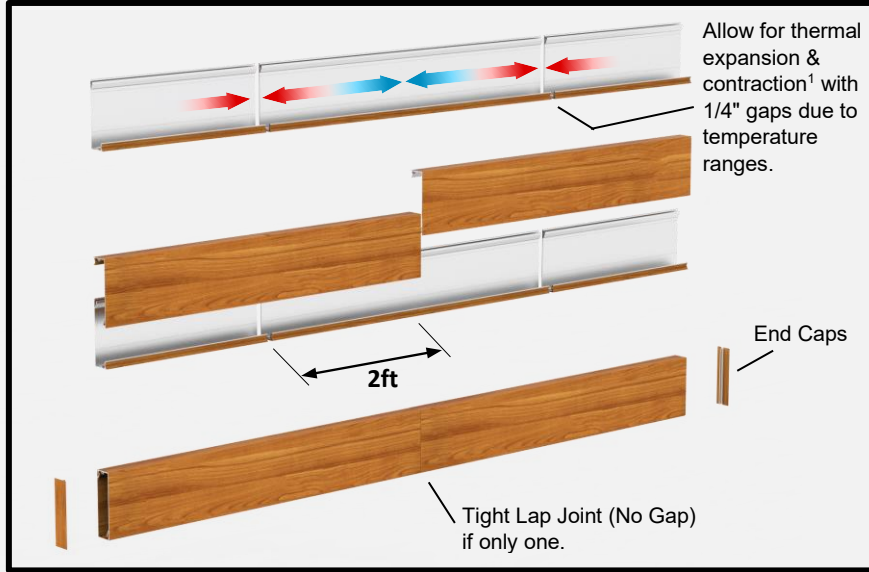

FASTENERS

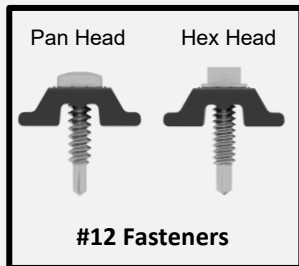
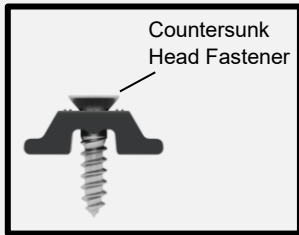

HARD FASTENER

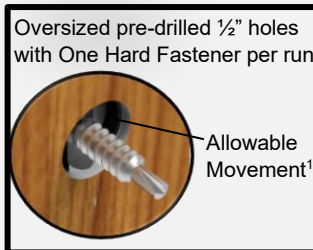
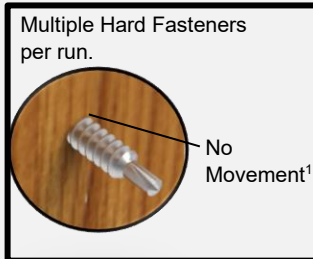

CANTILEVER

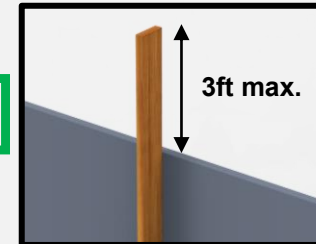
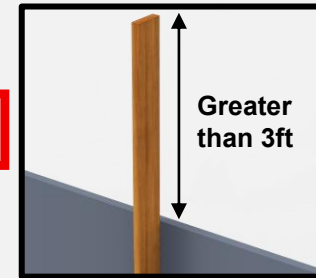

L&L Dimensions

Finishes:

Woodgrains, Solid, Specialty

Custom Solid Color Matching - (Additional lead times apply)



2" Link & Lock



4" Link & Lock



6" Link & Lock



8" Link & Lock

Actual Sizes & Weights

L&L	Width	Depth	Length	Weight(lbs/LF) *per set
2"	2" (50.8mm)	1 5/8" (41.3mm)	12'/24'	0.93
4"	4" (101.6mm)	1 5/8" (41.3mm)	12'/24'	1.3
6"	6" (152.4mm)	1 5/8" (41.3mm)	12'/24'	1.6
8"	8" (203mm)	1 5/8" (41.3mm)	12'/24'	1.9
4"x4"	4" (101.6mm)	4" (101.6mm)	12'/24'	1.8
4"x6"	4" (101.6mm)	6" (152.4mm)	12'/24'	2.1

Physical data:

- 6063-T5 Extruded Aluminum
- 100% recyclable
- Warranty on Finish: 15 year (standard)/20 year* (ultra) (*10week lead time); Aluminum: 50 year

Link & Lock™ Battens

Size	12'	24'	End Caps (20/box)	End Mounts (20/box)
2"	2X2LL.145	2X2LL.289	2LLEC.2	2LLEM.2
4"	2X4LL.145	2X4LL.289	2LLEC.4	2LLEM.4
6"	2X6LL.145	2X6LL.289	2LLEC.6	2LLEM.6
8"	2X8LL.145	2X8LL.289	2LLEC.8	2LLEM.8

Link & Lock™ Box Battens

4 x 4"	4X4LL.145	4X4LL.289	4LLEC.4	-
4 x 6"	4X6LL.145	4X6LL.289	4LLEC.6	-

Mounting Accessories	Qty	SKU
Link & Lock Mounting Clip	48, bag	LLMC.N48
Link & Lock™ Isolation Washer	48, bag	LLIW.N48
Dewalt® 1/2" Pilot Point Drill Bit	1	DRILLBT.05
24' Link & Lock Internal Stiffener	1	LLSTIFF.289
3M® Double Sided Adhesive Tape - 108'	1, roll	LLTAPE.1296



4"x4" Link & Lock



4"x6" Link & Lock

L&L Installation Components [See L&L Install Guide for details](#)



Mounting Clip:

- Nylon with embedded SS washer
- Used on Batten and Fin orientation to secure the back "L" to the substrate
- Included in order with L&L for 6' O.C. attachment
- Additional Clips purchased separately (48 pcs/box)



End Mount:

- Extruded 6063-T5 Aluminum Alloy, powder coated black
- Used for End-to-End attachment to provide a solid mount for the L&L set to wrap around and snap together
- Available for 2", 4", 6" & 8" L&L
- Purchased separately (20 pcs/box)



#12 Fastener (By others):

- Zinc-plated or Stainless Steel
- Used for attaching the back "L" to the substrate
- Use the correct fastener for the required project substrate
- Supplied by others



Isolation Washer:

- PA6 Nylon
- Used to isolate the back "L" from the substrate
- Max. 4x to shim L&L (1/4" total)
- 1/16" thick, 1 1/2" O.D.
- Purchased separately in packages of (48 pcs/box)



1/2" Pilot Point Drill Bit:

- 1/2" Pilot Point Drill Bit
- Used for Drilling out the holes for mounting the L&L to the substrate
- See Install Guide for drilling details



Paint Pen:

- Color choices available
- Used for touch ups at the ends before installing End Caps
- Purchased separately



Double-sided Adhesive Tape:

- 3M VHB Tape
- Used for attaching the Internal Stiffener to the back "L" of the L&L set
- Tape is placed in the center of the Stiffener



Internal Stiffener:

- Extruded 6063-T5 Aluminum Alloy (comes powder coated black)
- Used for reinforcing the 4", 6" & 8" L&L to allow for up to 12' spans between attachment points
- See Testing and Loading page for span allowance

L&L Install Images

See L&L Install Guide for details

BIM & CAD: RVT & DWG files available, see website for details

Mounting Clip (Fin orientation)

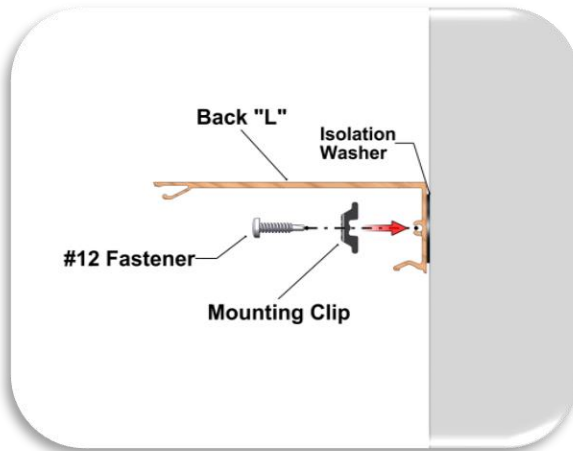

End Mount

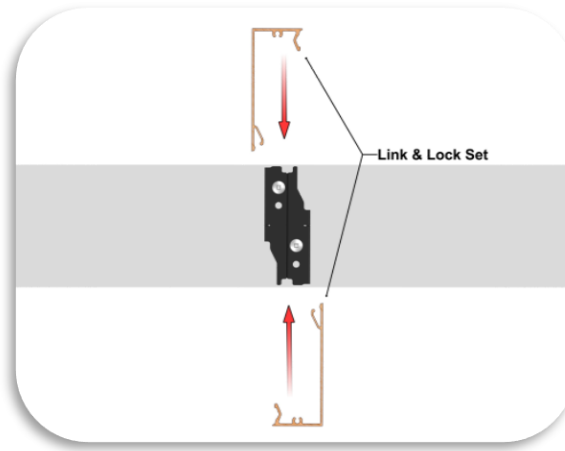

Internal Stiffener (with Double-sided Tape)

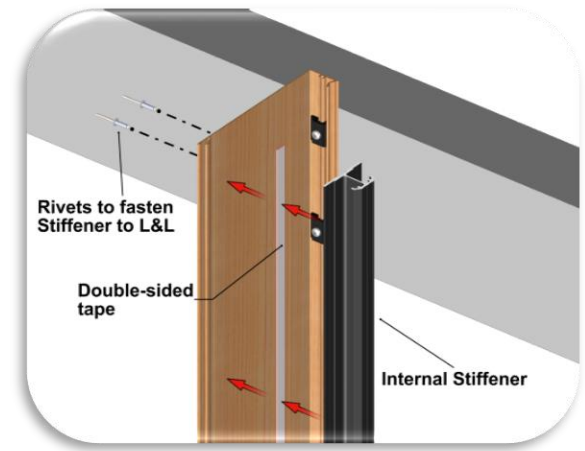

Mounting Clip (Batten orientation)

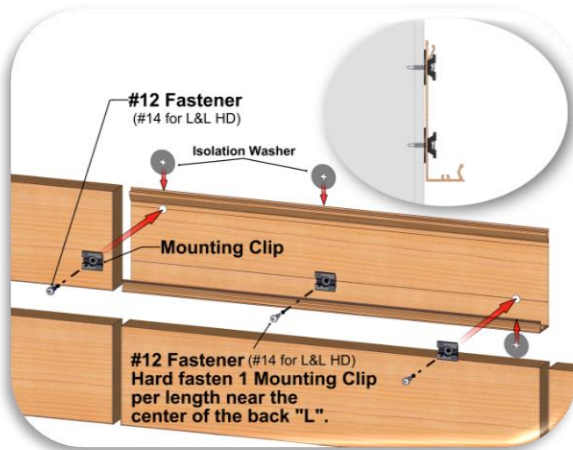

Paint Pen (for cut edges)

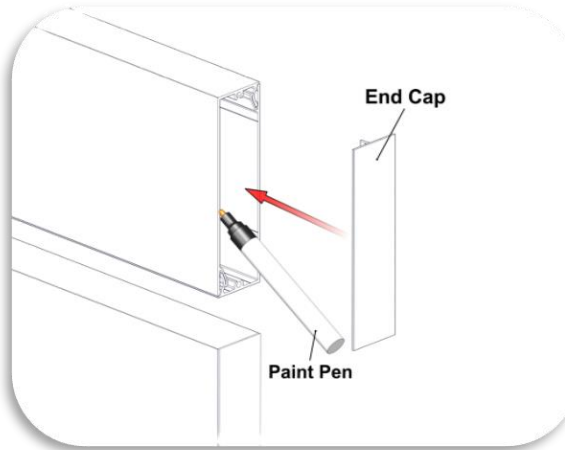

Drilling (Fin orientation)



L&L HD Components

Finishes:
Woodgrains, Solid, Specialty
Custom Solid Color Matching - (Additional lead times apply)



4" Link & Lock HD



6" Link & Lock HD



8" Link & Lock HD



Link & Lock HD End Mount

Actual Sizes & Weights

L&L	Width	Depth	Length	Weight(lbs/LF) *per set
4"	4" (101.6mm)	2" (50.8mm)	12'/24'	1.7
6"	6" (152.4mm)	2" (50.8mm)	12'/24'	2.4
8"	8" (203mm)	2" (50.8mm)	12'/24'	3

Size	12'	24'	End Caps (20/box)	End Mounts (20/box)
4"	2X4LLHD.145	2X4LLHD.289	2LLHDEC.4	2LLHDEM.4
6"	2X6LLHD.145	2X6LLHD.289	2LLHDEC.6	2LLHDEM.6
8"	2X8LLHD.145	2X8LLHD.289	2LLHDEC.8	2LLHDEM.8

Mounting Accessories	Qty	SKU
Link & Lock Mounting Clip	48, bag	LLMC.N48
Link & Lock™ Isolation Washer	48, bag	LLIW.N48
Dewalt® 1/2" Pilot Point Drill Bit	1	DRILLBT.05

Physical data:

- 6063-T5 Extruded Aluminum
- 100% recyclable
- Warranty on Finish: 15 year (standard)/20 year* (ultra) (*10week lead time); Aluminum: 50 year

BIM & CAD:

- RVT & DWG files to be available

Mounting Clip:



- Nylon with embedded SS washer
- Used on Batten and Fin orientation to secure the back "L" to the substrate
- Included in order with L&L for 6' O.C. attachment
- Additional Clips purchased separately (48 pcs/box)

1/2" Pilot Point Drill Bit:



- 1/2" Pilot Point Drill Bit
- Used for Drilling out the holes for mounting the L&L to the substrate
- See Install Guide for drilling details

Isolation Washer:



- PA6 Nylon
- Used to isolate the back "L" from the substrate
- Max. 4x to shim L&L (1/4" total)
- 1/16" thick, 1 1/2" O.D.
- Purchased separately in packages of (48 pcs/box)

#14 Fastener



- Eng. & Load Dependent (By others):
- Zinc-plated or Stainless Steel
- Used for attaching the back "L" to the substrate
- Use the correct fastener for the required project substrate
- Supplied by others

L&L Testing Data and Allowable Spans

See L&L Install Guide for details

2" LINK & LOCK™		FASTENER SPACING - LOAD TABLE										
Standard		PSF (Factored / Ultimate)										
		20	30	40	50	60	70	80	90	100	110	120
ALLOWABLE SPAN (FT)	4'											
	6'											
	8'											
	10'											

*CANTILEVERS are not to exceed half (1/2) the allowable span to a maximum of 3'

Calculations are using L/180 deflection limits

SUBSTRATE TYPE	SUBSTRATE REQUIREMENTS	ANCHOR DESCRIPTION	MIN. EMBEDMENT	MIN. EDGE DISTANCE
WOOD	Min. specific gravity = 0.55 wood	#12 Pan Head Wood Screw	1-1/2"	1"
STEEL	Min. 18 ga., Min. Fy=33 ksi.	#12 Self-Drilling or Self-Tapping Screw (Grade 5)	3 threads penetration past metal structure	1/2"
ALUMINUM	Min. 1/8", Min. 6063-T5			
CONCRETE	Min. 3000 psi	3/16" ITW Tapcon	1-1/2"	1-3/4"
HOLLOW/GROUT-FILLED CMU	Conforms to ASTM C-90, with Min. compressive strength of 2000 psi		1"	2"

GENERAL NOTES:

- This product has been designed and manufactured to comply with the current Florida Building Code (FBC), **INCLUDING** HVHZ and has been evaluated according to the following:
 - Section 1709.8
 - ASTM E8-16
- Adequacy of the structural concrete/masonry and 2X framing as a main wind force resisting system capable of withstanding and transferring applied product loads to the foundation is the responsibility of the engineer or architect of record for the project of installation.
- Substrate shall be designed and anchored to properly transfer all loads to the structure. Buck design and installation is the responsibility of the engineer or architect of record for the project of installation.
- The installation details described herein are generic and may not reflect actual conditions for a specific site. If site conditions cause installation to deviate from the requirements detailed herein, a licensed engineer or architect shall prepare site specific documents for use with this document.
- Link & Lock is not designed to be a life-safety item. Designs of this nature are the responsibility of the engineer or architect of record.

INSTALLATION NOTES:

- One (1) installation anchor is required at each location. Minimum of two (2) anchors per batten.
- Spacing is from fastener center to center.
- The number of installation anchors per the table is the minimum number of anchors to be used for product installation.
- Install individual installation anchors within a tolerance of +/- 1/2" of the specified spacings. Tolerances are not cumulative from one installation anchor to the next.
- Minimum embedment and edge distance exclude wall finishes, including but not limited to stucco, foam, brick veneer, sheathing and siding.
- Installation anchors and associated hardware must be made of corrosion resistant material or have a corrosion resistant coating. Common fastener types can be equal or better to a & b listed below.
 - Zinc plated fasteners for moderate climate zones
 - 316 Stainless Steel fasteners for coastal climate zones
- For hollow block and grout filled CMU block, do not install installation anchors into mortar joints. Edge distance is measured from free edge of block or edge of mortar joint into face shell of block.
- Installation anchors shall be installed in accordance with anchor manufacturer's installation instructions, and anchors shall not be used in substrates with strengths less than the minimum strength specified by the anchor manufacturer.
- When using end mounts, span distance is measured center to center of each end mount.

Testing:
 ICC-ESR 4183 Evaluation Report -
 Division: 05 00 00 – METALS
 • Section: 05 50 00 - Metal Fabrications

LARR - Los Angeles Department of Building Safety (LADBS) accepts ICC-ES reports as proof of compliance

Florida Product Code: FL41842

International Building Code (IBC).
 International Residential Code (IRC)
 California Building Code (CBC)
 California Residential Code (CRC)
 City of Los Angeles Building Code (LABC), City of Los Angeles Residential Code (LARC)
 Florida Building Code – Building
 Florida Building Code - Residential

 Fire Rating: Class A Non-Combustible by ASTM E136 & ASTM E84

 Light Reflectance: 5% (Black) up to 73.2% (Ultra White)

FASTENER SPACING - LOAD TABLE

4" LINK & LOCK™			PSF (Factored / Ultimate)													
			20	30	40	50	60	70	80	90	100	110	120			
Standard	Standard w. Stiffener	HD														
ALLOWABLE SPAN (FT)*	2'															
	4'									Standard w. Stiffener						
	6'							Standard w. Stiffener		HD						
	8'				Standard w. Stiffener			HD								
	10'		Standard w. Stiffener			HD										
	12'		Standard w. Stiffener		HD											

*CANTILEVERS are not to exceed half (1/2) the allowable span to a maximum of 3'

Calculations are using L/180 deflection limits

SUBSTRATE TYPE	SUBSTRATE REQUIREMENTS	ANCHOR DESCRIPTION	MIN. EMBEDMENT	MIN. EDGE DISTANCE
WOOD	Min. specific gravity = 0.55 wood	#12 Pan Head Wood Screw	1-1/2"	1"
STEEL	Min. 18 ga., Min. Fy=33 ksi.	#12 Self-Drilling or Self-Tapping Screw (Grade 5)	3 threads penetration past metal structure	1/2"
ALUMINUM	Min. 1/8", Min. 6063-T5			
CONCRETE	Min. 3000 psi	3/16" ITW Tapcon	1-1/2"	1-3/4"
HOLLOW/GROUT-FILLED CMU	Conforms to ASTM C-90, with Min. compressive strength of 2000 psi		1"	2"

GENERAL NOTES:

- This product has been designed and manufactured to comply with the current Florida Building Code (FBC), **INCLUDING** HVHZ and has been evaluated according to the following:
 - Section 1709.8
 - ASTM E8-16
- Adequacy of the structural concrete/masonry and 2X framing as a main wind force resisting system capable of withstanding and transferring applied product loads to the foundation is the responsibility of the engineer or architect of record for the project of installation.
- Substrate shall be designed and anchored to properly transfer all loads to the structure. Buck design and installation is the responsibility of the engineer or architect of record for the project of installation.
- The installation details described herein are generic and may not reflect actual conditions for a specific site. If site conditions cause installation to deviate from the requirements detailed herein, a licensed engineer or architect shall prepare site specific documents for use with this document.
- Link & Lock is not designed to be a life-safety item. Designs of this nature are the responsibility of the engineer or architect of record.

INSTALLATION NOTES:

- One (1) installation anchor is required at each location. Minimum of two (2) anchors per batten.
- Spacing is from fastener center to center.
- The number of installation anchors per the table is the minimum number of anchors to be used for product installation.
- Install individual installation anchors within a tolerance of +/- 1/2" of the specified spacings. Tolerances are not cumulative from one installation anchor to the next.
- Minimum embedment and edge distance exclude wall finishes, including but not limited to stucco, foam, brick veneer, sheathing and siding.
- Installation anchors and associated hardware must be made of corrosion resistant material or have a corrosion resistant coating. Common fastener types can be equal or better to a & b listed below.
 - Zinc plated fasteners for moderate climate zones
 - 316 Stainless Steel fasteners for coastal climate zones
- For hollow block and grout filled CMU block, do not install installation anchors into mortar joints. Edge distance is measured from free edge of block or edge of mortar joint into face shell of block.
- Installation anchors shall be installed in accordance with anchor manufacturer's installation instructions, and anchors shall not be used in substrates with strengths less than the minimum strength specified by the anchor manufacturer.
- When using end mounts, span distance is measured center to center of each end mount.

FASTENER SPACING - LOAD TABLE

6" LINK & LOCK™			PSF (Factored / Ultimate)										
Standard	Standard w. Stiffener	HD	20	30	40	50	60	70	80	90	100	110	120
ALLOWABLE SPAN (FT)*	2'												
	4'												Standard w. Stiffener
	6'				Standard w. Stiffener	HD							
	8'	Standard w. Stiffener		HD									
	10'	Standard w. Stiffener		HD									
	12'	HD											

*CANTILEVERS are not to exceed half (1/2) the allowable span to a maximum of 3'

Calculations are using L/180 deflection limits

SUBSTRATE TYPE	SUBSTRATE REQUIREMENTS	ANCHOR DESCRIPTION	MIN. EMBEDMENT	MIN. EDGE DISTANCE
WOOD	Min. specific gravity = 0.55 wood	#12 Pan Head Wood Screw	1-1/2"	1"
STEEL	Min. 18 ga., Min. Fy=33 ksi.	#12 Self-Drilling or Self-Tapping Screw (Grade 5)	3 threads penetration past metal structure	1/2"
ALUMINUM	Min. 1/8", Min. 6063-T5			
CONCRETE	Min. 3000 psi	3/16" ITW Tapcon	1-1/2"	1-3/4"
HOLLOW/GROUT-FILLED CMU	Conforms to ASTM C-90, with Min. compressive strength of 2000 psi		1"	2"

GENERAL NOTES:

- This product has been designed and manufactured to comply with the current Florida Building Code (FBC), **INCLUDING** HVHZ and has been evaluated according to the following:
 - Section 1709.8
 - ASTM E8-16
- Adequacy of the structural concrete/masonry and 2X framing as a main wind force resisting system capable of withstanding and transferring applied product loads to the foundation is the responsibility of the engineer or architect of record for the project of installation.
- Substrate shall be designed and anchored to properly transfer all loads to the structure. Buck design and installation is the responsibility of the engineer or architect of record for the project of installation.
- The installation details described herein are generic and may not reflect actual conditions for a specific site. If site conditions cause installation to deviate from the requirements detailed herein, a licensed engineer or architect shall prepare site specific documents for use with this document.
- Link & Lock is not designed to be a life-safety item. Designs of this nature are the responsibility of the engineer or architect of record.

INSTALLATION NOTES:

- One (1) installation anchor is required at each location. Minimum of two (2) anchors per batten.
- Spacing is from fastener center to center.
- The number of installation anchors per the table is the minimum number of anchors to be used for product installation.
- Install individual installation anchors within a tolerance of +/- 1/2" of the specified spacings. Tolerances are not cumulative from one installation anchor to the next.
- Minimum embedment and edge distance exclude wall finishes, including but not limited to stucco, foam, brick veneer, sheathing and siding.
- Installation anchors and associated hardware must be made of corrosion resistant material or have a corrosion resistant coating. Comm on fastener types can be equal or better to a & b listed below:
 - Zinc plated fasteners for moderate climate zones
 - 316 Stainless Steel fasteners for coastal climate zones
- For hollow block and grout filled CMU block, do not install installation anchors into mortar joints. Edge distance is measured from free edge of block or edge of mortar joint into face shell of block.
- Installation anchors shall be installed in accordance with anchor manufacturer's installation instructions, and anchors shall not be used in substrates with strengths less than the minimum strength specified by the anchor manufacturer.
- When using end mounts, span distance is measured center to center of each end mount.

FASTENER SPACING - LOAD TABLE

8" LINK & LOCK™			PSF (Factored / Ultimate)										
			20	30	40	50	60	70	80	90	100	110	120
Standard	Standard w. Stiffener	HD											
ALLOWABLE SPAN (FT)*	2'												
	4'					Standard w. Stiffener							HD
	6'			Standard w. Stiffener	HD								
	8'	Standard w. Stiffener	HD										
	10'	HD											

*CANTILEVERS are not to exceed half (1/2) the allowable span to a maximum of 3'

Calculations are using L/180 deflection limits

SUBSTRATE TYPE	SUBSTRATE REQUIREMENTS	ANCHOR DESCRIPTION	MIN. EMBEDMENT	MIN. EDGE DISTANCE
WOOD	Min. specific gravity = 0.55 wood	#12 Pan Head Wood Screw	1-1/2"	1"
STEEL	Min. 18 ga., Min. Fy=33 ksi.	#12 Self-Drilling or Self-Tapping Screw (Grade 5)	3 threads penetration past metal structure	1/2"
ALUMINUM	Min. 1/8", Min. 6063-T5			
CONCRETE	Min. 3000 psi	3/16" ITW Tapcon	1-1/2"	1-3/4"
HOLLOW/GROUT-FILLED CMU	Conforms to ASTM C-90, with Min. compressive strength of 2000 psi		1"	2"

GENERAL NOTES:

- This product has been designed and manufactured to comply with the current Florida Building Code (FBC), **INCLUDING** HVHZ and has been evaluated according to the following:
 - Section 1709.8
 - ASTM E8-16
- Adequacy of the structural concrete/masonry and 2X framing as a main wind force resisting system capable of withstanding and transferring applied product loads to the foundation is the responsibility of the engineer or architect of record for the project of installation.
- Substrate shall be designed and anchored to properly transfer all loads to the structure. Buck design and installation is the responsibility of the engineer or architect of record for the project of installation.
- The installation details described herein are generic and may not reflect actual conditions for a specific site. If site conditions cause installation to deviate from the requirements detailed herein, a licensed engineer or architect shall prepare site specific documents for use with this document.
- Link & Lock is not designed to be a life-safety item. Designs of this nature are the responsibility of the engineer or architect of record.

INSTALLATION NOTES:

- One (1) installation anchor is required at each location. Minimum of two (2) anchors per batten.
- Spacing is from fastener center to center.
- The number of installation anchors per the table is the minimum number of anchors to be used for product installation.
- Install individual installation anchors within a tolerance of +/- 1/2" of the specified spacings. Tolerances are not cumulative from one installation anchor to the next.
- Minimum embedment and edge distance exclude wall finishes, including but not limited to stucco, foam, brick veneer, sheathing and siding.
- Installation anchors and associated hardware must be made of corrosion resistant material or have a corrosion resistant coating. Common fastener types can be equal or better to a & b listed below:
 - Zinc plated fasteners for moderate climate zones
 - 316 Stainless Steel fasteners for coastal climate zones
- For hollow block and grout filled CMU block, do not install installation anchors into mortar joints. Edge distance is measured from free edge of block or edge of mortar joint into face shell of block.
- Installation anchors shall be installed in accordance with anchor manufacturer's installation instructions, and anchors shall not be used in substrates with strengths less than the minimum strength specified by the anchor manufacturer.
- When using end mounts, span distance is measured center to center of each end mount.

FASTENER SPACING - LOAD TABLE

4X4 LINK & LOCK™		PSF (Factored / Ultimate)										
		20	30	40	50	60	70	80	90	100	110	120
Standard												
ALLOWABLE SPAN (FT)*		8'										
		10'										
		12'										

*CANTILEVERS are not to exceed 3'

Calculations are using L/180 deflection limits

SUBSTRATE TYPE	SUBSTRATE REQUIREMENTS	ANCHOR DESCRIPTION	MIN. EMBEDMENT	MIN. EDGE DISTANCE
WOOD	Min. specific gravity = 0.55 wood	#12 Pan Head or Flanged Hex Head Wood Screw	1-1/2"	1"
STEEL	Min. 18 ga., Min. Fy=36 ksi.	#12 Self-Drilling or Self-Tapping Screw Pan Head or Flanged Hex Head Wood Screw (Grade 5)	3 threads penetration past metal structure	1/2"
ALUMINUM	Min. 1/8", Min. 6063-T5			
CONCRETE	Min. 3000 psi	3/16" ITW Tapcon	1-1/2"	1-3/4"
HOLLOW/GROUT-FILLED CMU	Conforms to ASTM C-90, with Min. compressive strength of 2000 psi		1"	2"

GENERAL NOTES:

- Adequacy of the structural concrete/masonry and 2X framing as a main wind force resisting system capable of withstanding and transferring applied product loads to the foundation is the responsibility of the engineer or architect of record for the project of installation.
- Substrate shall be designed and anchored to properly transfer all loads to the structure. Buck design and installation is the responsibility of the engineer or architect of record for the project of installation.
- The installation details described herein are generic and may not reflect actual conditions for a specific site. If site conditions cause installation to deviate from the requirements detailed herein, a licensed engineer or architect shall prepare site specific documents for use with this document.
- Link & Lock is not designed to be a life-safety item. Designs of this nature are the responsibility of the engineer or architect of record.

INSTALLATION NOTES:

- One (1) installation anchor is required at each location. Minimum of two (2) anchors per batten.
- Spacing is from fastener center to center.
- The number of installation anchors per the table is the minimum number of anchors to be used for product installation.
- Install individual installation anchors within a tolerance of +/- 1/2" of the specified spacings. Tolerances are not cumulative from one installation anchor to the next.
- Minimum embedment and edge distance exclude wall finishes, including but not limited to stucco, foam, brick veneer, sheathing and siding.
- Installation anchors and associated hardware must be made of corrosion resistant material or have a corrosion resistant coating. Common fastener types can be equal or better to a & b listed below:
 - Zinc plated fasteners for moderate climate zones
 - 316 Stainless Steel fasteners for coastal climate zones
- For hollow block and grout filled CMU block, do not install installation anchors into mortar joints. Edge distance is measured from free edge of block or edge of mortar joint into face shell of block.
- Installation anchors shall be installed in accordance with anchor manufacturer's installation instructions, and anchors shall not be used in substrates with strengths less than the minimum strength specified by the anchor manufacturer.

4X6 LINK & LOCK™		PSF (Factored / Ultimate)										
		20	30	40	50	60	70	80	90	100	110	120
Standard												
ALLOWABLE SPAN (FT)*	8'											
	10'											
	12'											

*CANTILEVERS are not to exceed 3'

Calculations are using L/180 deflection limits

SUBSTRATE TYPE	SUBSTRATE REQUIREMENTS	ANCHOR DESCRIPTION	MIN. EMBEDMENT	MIN. EDGE DISTANCE
WOOD	Min. specific gravity = 0.55 wood	#12 Pan Head or Flanged Hex Head Wood Screw	1-1/2"	1"
STEEL	Min. 18 ga., Min. Fy=36 ksi.	#12 Self-Drilling or Self-Tapping Screw Pan Head or Flanged Hex Head Wood Screw (Grade 5)	3 threads penetration past metal structure	1/2"
ALUMINUM	Min. 1/8", Min. 6063-T5			
CONCRETE	Min. 3000 psi	3/16" ITW Tapcon	1-1/2"	1-3/4"
HOLLOW/GROUT-FILLED CMU	Conforms to ASTM C-90, with Min. compressive strength of 2000 psi		1"	2"

GENERAL NOTES:

- Adequacy of the structural concrete/masonry and 2X framing as a main wind force resisting system capable of withstanding and transferring applied product loads to the foundation is the responsibility of the engineer or architect of record for the project of installation.
- Substrate shall be designed and anchored to properly transfer all loads to the structure. Buck design and installation is the responsibility of the engineer or architect of record for the project of installation.
- The installation details described herein are generic and may not reflect actual conditions for a specific site. If site conditions cause installation to deviate from the requirements detailed herein, a licensed engineer or architect shall prepare site specific documents for use with this document.
- Link & Lock is not designed to be a life-safety item. Designs of this nature are the responsibility of the engineer or architect of record.

INSTALLATION NOTES:

- One (1) installation anchor is required at each location. Minimum of two (2) anchors per batten.
- Spacing is from fastener center to center.
- The number of installation anchors per the table is the minimum number of anchors to be used for product installation.
- Install individual installation anchors within a tolerance of +/- 1/2" of the specified spacings. Tolerances are not cumulative from one installation anchor to the next.
- Minimum embedment and edge distance exclude wall finishes, including but not limited to stucco, foam, brick veneer, sheathing and siding.
- Installation anchors and associated hardware must be made of corrosion resistant material or have a corrosion resistant coating. Common fastener types can be equal or better to a & b listed below:
 - Zinc plated fasteners for moderate climate zones
 - 316 Stainless Steel fasteners for coastal climate zones
- For hollow block and grout filled CMU block, do not install installation anchors into mortar joints. Edge distance is measured from free edge of block or edge of mortar joint into face shell of block.
- Installation anchors shall be installed in accordance with anchor manufacturer's installation instructions, and anchors shall not be used in substrates with strengths less than the minimum strength specified by the anchor manufacturer.

L&L Bracket Components

Single Bracket for horizontal substrate

Fixed Bracket (Hard fastened with 1/4" holes)

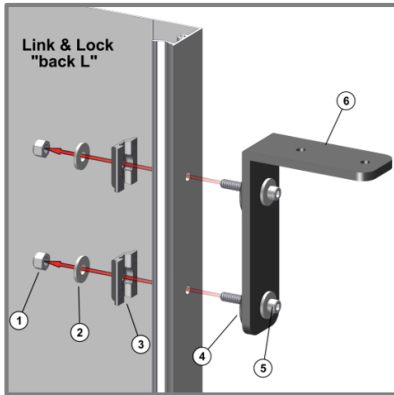

Fixed Bracket (Expansion 1/2" holes)

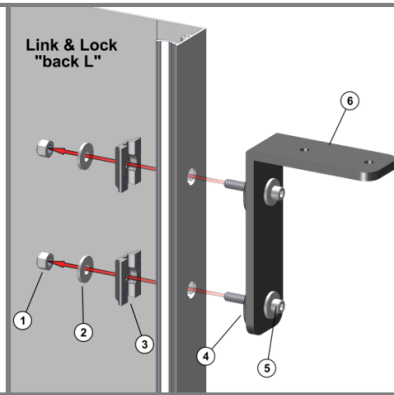

No.	Description	Material	Qty
1	1/4" -20 Locknut	Stainless Steel Nylon-Insert	2
2	Washer, 1/4" screw size, 0.75" OD	Stainless Steel	4
3	Link & Lock Mounting Clip	Nylon w. Stainless Washer	2
4	Isolation Washer for 1/4" size	Nylon, Black	2
5	1/4" -20 Socket Head Screw, 1-1/2" length	Stainless Steel	2
6	Link & Lock Bracket -90 Center Fixed	6005A Aluminum	1

Sliding Bracket (Use 1/4" holes)

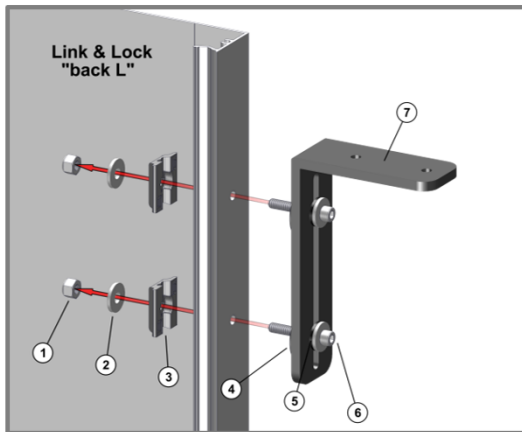

No.	Description	Material	Qty
1	1/4" -20 Locknut	Stainless Steel Nylon-Insert	2
2	Washer, 1/4" screw size, 0.75" OD	Stainless Steel	4
3	Link & Lock Mounting Clip	Nylon w. Stainless Washer	2
4	Isolation Washer for 1/4" screw size	Nylon, Black	2
5	Plastic Washer, 1/4" screw size, 0.734 OD	Nylon, Black	2
6	1/4" -20 Socket Head Screw, 1-1/2" length	Stainless Steel	2
7	Link & Lock Bracket -90 Center Sliding	6005A Aluminum	1

Link & Lock™ Mounting Brackets

Product	Single	Dual
45° LEFT FIXED	LLMBK.45LF	LLDMBK.45LF
45° RIGHT FIXED	LLMBK.45RF	LLDMBK.45RF
90° CENTER FIXED	LLMBK.90F	LLDMBK.90F
45° LEFT SLIDING	LLMBK.45LS	LLDMBK.45LS
45° RIGHT SLIDING	LLMBK.45RS	LLDMBK.45RS
90° CENTER SLIDING	LLMBK.90S	LLDMBK.90S

Link & Lock System Info Sheet Package

L&L_ISP_RN_V08

Dual Bracket for vertical substrate

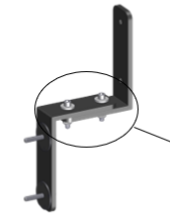
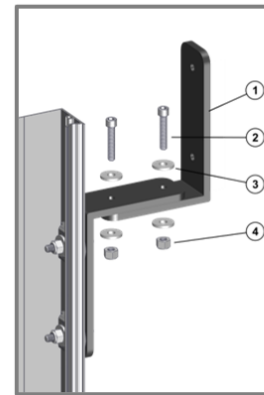

Dual Bracket components are loosely pre-assembled by manufacturer. Adjust if required. Once in place add lubricant and tighten to manufacturer's specifications. See below for lubricant specs.

No.	Description	Material	Qty
1	Link & Lock Dual Bracket -90 Center Fixed	6005A Aluminum	1
2	1/4" -20 Socket Head Screw, 1-1/4" length	Stainless Steel	2
3	Washer, 1/4" screw size, 0.75" OD	Stainless Steel	4
4	1/4" -20 Locknut	Stainless Steel Nylon-Insert	2

Add 1/8" drop of lubricant to all bolt threads before installing locknut.

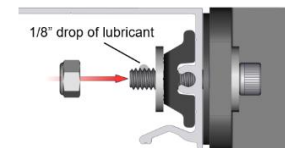

For L&L Bracket fastening, use Permatex Anti-Seize 77134.



Note: Use Sliding Bracket only when attachment conditions require large movement. (Ex. Slab deflection in parking garages).

L&L Bracket Orientation Options

Fixed options shown, sliding options are available for slab deflection or building settlement.



Left



Center



Right



Center Horizontal Batten



Center Vertical Batten

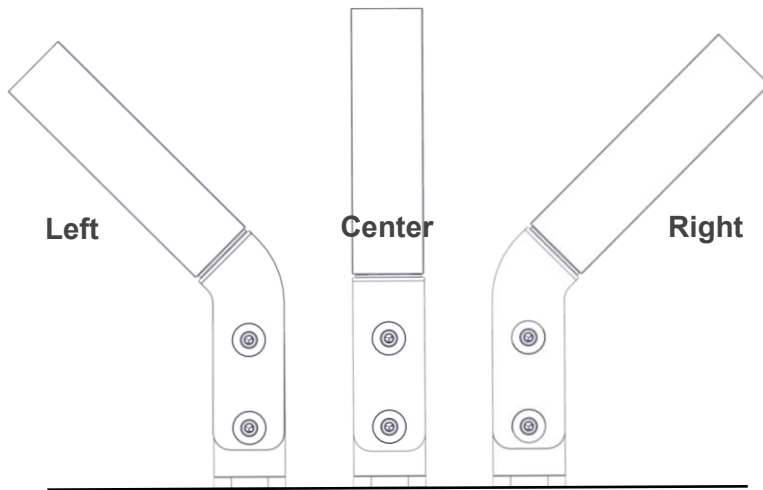

Left

Center

Right

Building/Structure



L&L Bracket Dimensions

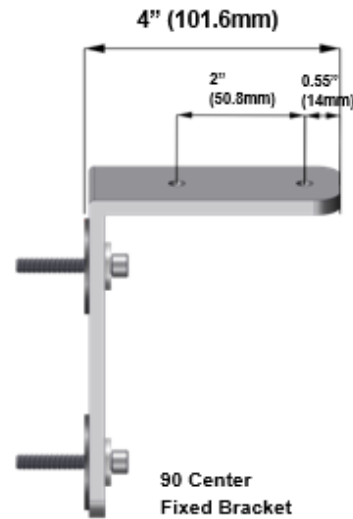
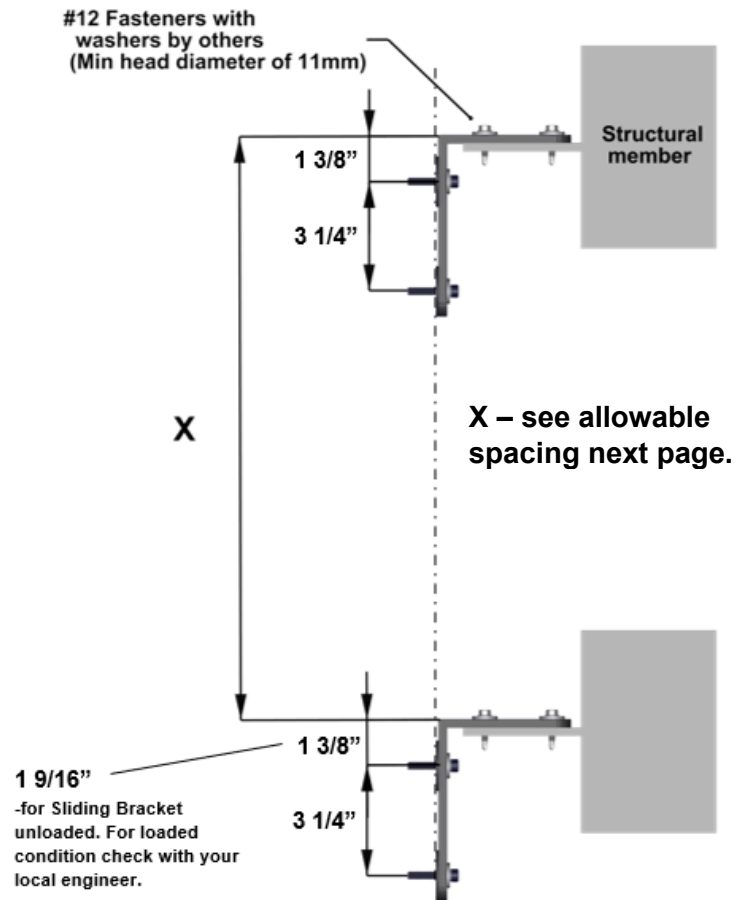

Tools for Bracket Install to L&L



7/16" Nut Driver
Fixed & Sliding
Brackets



3/16" Allen Key
Fixed & Sliding
Brackets

L&L Bracket Installation, Load Data & Allowable Spacing

See [L&L Install Guide](#) for details

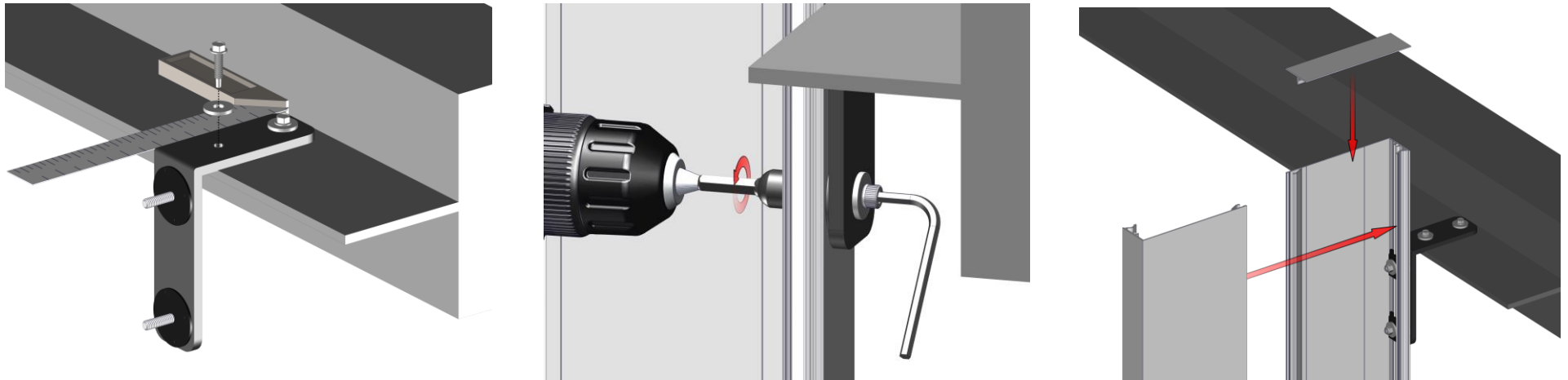

LINK & LOCK™ BATTEN	LINK & LOCK™ BRACKET MAX. SPACING (FT)									
	WIND LOAD PSF (FACTORED/ULTIMATE)									
	30	40	50	60	70	80	90	100	110	120
1-5/8" x 2"	10'	8'	6'	6'	4'	4'	2'	2'	2'	2'
1-5/8" x 4"	8'	6'	4'	4'	2'	2'	2'	2'	2'	2'
1-5/8" x 4" w. Internal Stiffener	12'	10'	8'	6'	6'	4'	4'	4'	4'	4'
1-5/8" x 6"	6'	4'	4'	3'	3'	3'	2'	2'	2'	2'
1-5/8" x 6" w. Internal Stiffener	10'	8'	6'	4'	4'	3'	3'	3'	2'	2'
1-5/8" x 8"	6'	4'	2'	2'	2'	2'	2'	2'	2'	2'
1-5/8" x 8" w. Internal Stiffener	8'	6'	4'	4'	3'	3'	2'	2'	2'	2'
2" x 4" HD	12'	10'	8'	6'	6'	4'	4'	4'	4'	4'
2" x 6" HD	10'	8'	6'	4'	4'	3'	3'	3'	3'	3'
2" x 8" HD	8'	6'	4'	4'	3'	3'	2'	2'	2'	2'

Recommended torque value for Link & Lock™ to Bracket attachment:

note 1 Factored Wind Load: max. 168 LBS/EA Bracket

note 2 Factored Dead Load: max. 29 LBS/EA Fixed Bracket

note 3 Fixed Bracket 1/4" -20 Socket Head Screw, 60-72 in/lbs + prevailing torque of self-locking nut

note 4 Sliding Bracket 1/4" -20 Socket Head Screw, 48-60 in/lbs + prevailing torque of self-locking nut

April 25, 2024